

Section 21  
TABLE OF CONTENTS  
Fall Protection

Section:	Page
21.A General .....	21-1
21.B <u>Roles and Responsibilities</u> .....	21-4
21.C Training .....	21-7
21.D Fall Protection Program .....	21-10
21.E Controlled Access Zones .....	21-11
21.F Fall Protection Systems .....	21-11
21.G Covers .....	21-14
21.H Safety Net Systems <u>for Fall Protection</u> .....	21-15
21.I Personal Fall Protection Systems .....	21-17
21.J Ladder-Climbing Devices (LCDs) .....	21-24
21.K Scaffolds, <u>Work Platforms and Elevating/Aerial Platforms</u> .....	21-25
21.L Warning Line Systems (WLS) .....	21-27
21.M Safety Monitoring System (SMS) .....	21-28
21.N Rescue Plan and Procedures .....	21-29
21.O Working Over or Near Water .....	21-30
21.P <u>Other Engineered Fall Protection Systems</u> .....	21-32
Figures:	
<u>21-1 – Control Zone/Safe Zone Fall Protection</u> .....	21-3

EM 385-1-1  
30 Nov 14

<u>21-2 – Existing Parapet Wall Used as a Fall Protection System</u> .....	21-15
<u>21-3 – Calculating Fall Distance</u> .....	21-19
<u>21-4 – 6 ft Free Fall and 12 ft Free Fall Energy Absorbing Lanyard Labels</u> .....	21-21
<u>21-5 – Typical Examples of Manually Propelled Elevating Aerial Platforms</u> .....	21-27
<u>21-6 – Designated Area</u> .....	21-29
<u>21-7 – Fall Protection (FP) vs. Personal Flotation Device (PFD) Use When Working Over or Near Water</u> .....	21-31

Tables:

21-1 – Safety Net Distances .....	21-16
-----------------------------------	-------

THIS PAGE INTENTIONALLY LEFT BLANK

## SECTION 21

### Fall Protection

21.A General. The requirements of this Section are applicable to all Government and Contractor work forces when their employees are working at heights, exposed to fall hazards and/or using fall protection equipment. Every Contractor and USACE-owned/operated permanent facility is responsible for establishing, implementing and managing a fall protection program.

#### 21.A.01 Fall Protection Threshold.

a. The fall protection threshold height requirement is 6 ft (1.8 m) for ALL work covered by this manual, unless specified differently below, whether performed by Government or Contractor work forces, to include steel erection activities, systems-engineered activities (prefabricated) metal buildings, residential (wood) construction and scaffolding work.

b. For all USACE-owned/operated permanent facilities with open-sided floors, platforms or unprotected edges 4 ft (1.2 m) or more above adjacent floor or ground level, see Section 24.A.01.d.

➤ Note 1: Floating Plant and Vessels are excluded from these requirements except where specifically cited in Sections 19.D and 19.E.

➤ Note 2: For fall protection requirements in excavations, see Section 25.A.02.

➤ Note 3: The Terms “CP” And “QP” in this section refer to Competent Person for fall protection and Qualified Person for Fall Protection respectively. > See Sections 21.B.02, 21.B.03 and Appendix Q.

21.A.02 Workers exposed to fall hazards shall be protected from falling to a lower level by the use of standard guardrails (see Section 21.F.01.b), work platforms, temporary floors, safety nets, engineered fall protection systems, personal fall arrest systems, or the equivalent, in the following situations:

a. Whenever workers are exposed to falls from unprotected sides or edges, access ways, fixed ladders over 20 ft (6 m) in height, unprotected roof edge or floor openings, holes and skylights, unstable surfaces, leading edge work, scaffolds, formwork, work platforms, re-bar assembly, steel erection and engineered metal buildings;

b. For access ways or work platforms over water, machinery, or dangerous operations;

c. When installing or removing sheet piles, h-piles, cofferdams, or other interlocking materials from which workers may fall 6 ft (1.8 m) or more;

➤ Note: The use of sheet pile stirrups as a fall protection method is prohibited.

d. Where there is a possibility of a fall from any height onto dangerous equipment, into a hazardous environment, or onto an impalement hazard;

e. For steel erection activities, when connectors are working at the same connecting point, they shall connect one end of the structural member before going out to connect the other end. The connectors shall always be 100% tied off.

21.A.03 The order of control measures (the hierarchy of controls) to abate fall hazards or to select and use a fall protection method to protect workers performing work at heights shall be:

a. Elimination: Remove the hazard from work areas or change task, process, controls or other means to eliminate the need to work at heights with its subsequent exposure to fall hazards (i.e., build roof trusses on ground level and then lift into place or design change by lowering a meter or valve at high locations to a worker's level). This control measure is the most effective;

b. Prevention (passive or same-level barrier): isolate and separate fall hazards from work areas by erecting same level barriers such as guardrails, walls, covers or parapets;

c. Work platforms (movable or stationary): use scaffolds, scissor lifts, work stands or aerial lift equipment to facilitate access to work location and to protect workers from falling when performing work at high locations. > See Section 22.S;

d. Personal Protective Systems and Equipment: Use of fall protection systems, including (in order of preference): restraint, positioning, or personal fall arrest. All systems require the use of full body harness, connecting means and safe anchorage system.

e. Administrative Controls: Introduce new work practices that reduce the risk of falling from heights, or to warn a person to avoid approaching a fall hazard (i.e., warning systems, warning lines, audible alarms, signs or training of workers to recognize specific fall hazards).

21.A.04 When using stilts, working from raised platforms, or floors above a walking/working surface that exposes workers to a fall of 6 ft (1.8 m) or more in areas protected by guardrails, the height of the guardrail must be raised accordingly to maintain a protective height of 42 in (107 cm) above the stilt, raised platform, floors, or work stands.

21.A.05 During construction activities, fall protection is required for employees exposed to fall hazards while conducting inspection, investigation or assessment work.

21.A.06 Prior to start of construction or after construction work is complete, fall protection is required when conducting inspection, investigation or assessment work WITHIN 6 ft (1.8 m) from an unprotected edge of a roof. An AHA shall be developed and reviewed by a CP for this activity and submitted for GDA review and acceptance. > See Figure 21-1.

21.A.07 Prior to start of construction or after construction work is complete, fall protection may not be required when conducting inspection, investigation or assessment work MORE THAN 6 ft (1.8 m) away from an unprotected edge of a roof. An AHA shall be developed and reviewed by a CP for this activity and submitted for GDA review and acceptance. ≥ See Figure 21-1.

21.A.08 During maintenance evolutions (i.e., inspecting or maintaining HVAC or other equipment on roofs), fall protection is required when conducting inspection and investigation work.

Figure 21-1  
Control Zone/Safe Zone Fall Protection

FP is required in the Control Zone when conducting inspection, investigation or assessment work of roofs

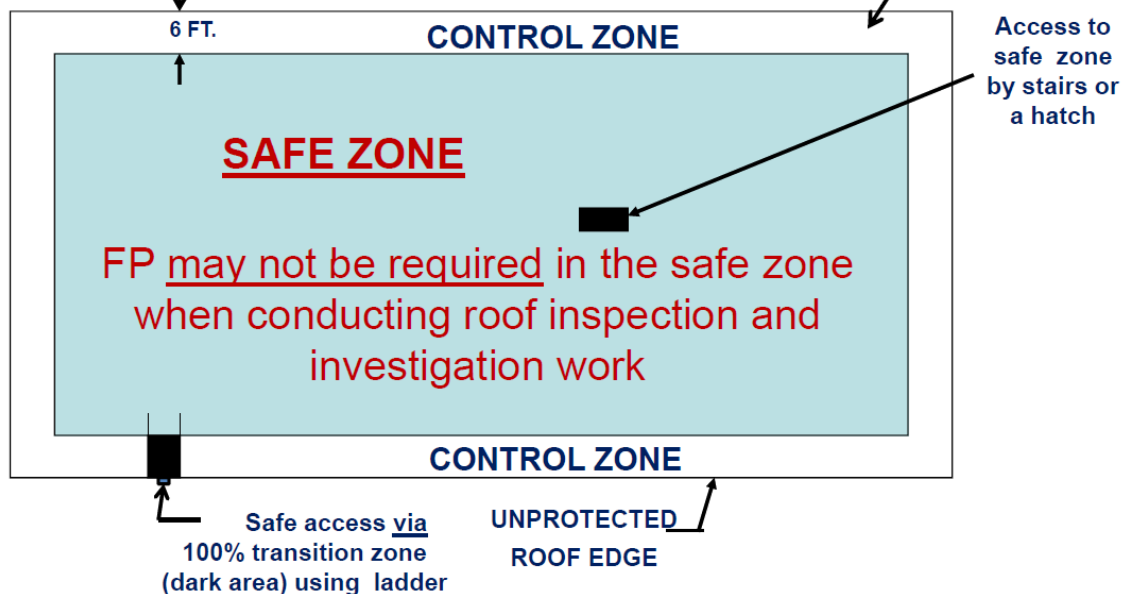

21.B Roles and Responsibilities.

21.B.01 Fall Protection Program Manager (Program Administrator per ANSI Z359.2). The Program Manager is responsible for the overall development, implementation, monitoring and evaluation of the Fall Protection Program. This person can also function as a QP, CP, CP trainer, QP trainer and/or competent rescue trainer if so trained. The Program Manager shall:

- a. Be trained appropriately, as described in Section 21.C;
- b. Advise and provide guidance for managers, employees and others on all matters pertaining to their Fall Protection Program;
- c. Establish all duties and responsibilities required by the Fall Protection Program and assign them to individuals who are trained and qualified to perform them;
- d. Verify personnel are provided with resources to accomplish their responsibilities;
- e. Establish and implement a procedure to identify and eliminate or control new and existing fall hazards;
- f. Ensure the proper development and implementation of the fall protection and prevention plan (written Fall Protection Procedures, per ANSI Z359.2) and rescue plan (written Rescue Procedures, per ANSI Z359.2).
- g. Provide/ensure appropriate level of training is received by End Users (Authorized Persons per ANSI Z359.2), CP, QP, and others as required;
- h. Participate in investigation of all mishaps (near misses, incidents or accidents) related to falls from heights (personally or by designation of persons qualified to perform the investigation);
- i. Measure and evaluate the effectiveness of the Fall Protection Program by conducting periodic program evaluations and making improvements as necessary.

21.B.02 Qualified Person for Fall Protection. The QP is responsible for technical support of the Fall Protection Program. The QP shall:

- a. Have advanced understanding and knowledge of the requirements, equipment and systems, physical sciences, and engineering principles that affect equipment and systems for fall protection and rescue;
- b. Be qualified to select proper fall protection and rescue equipment;
- c. Supervise the design, selection, installation and inspection of certified anchorages and horizontal lifelines;

d. Be trained to the applicable level, as described in Section 21.C.

21.B.03 Competent Person for Fall protection. The CP is responsible for the immediate supervision, implementation and monitoring of the Fall Protection Program. The CP shall:

a. Be trained to the applicable level, as described in Section 21.C;

b. Conduct a fall hazard survey to identify all fall hazards before End Users are exposed to those hazards;

c. Identify, evaluate and impose limits on the workplace activities to control fall hazard exposures and swing falls and communicate all limitations to all employees authorized to utilize the fall protection system;

d. Have the authority to stop the work immediately if it is determined to be unsafe and take prompt corrective measures to mitigate fall hazards;

e. Prepare, update, review and approve fall protection and prevention plans as directed by the Program Manager.

f. Review procedures as workplace activities change to determine if additional practices, procedures or training need to be implemented;

g. Ensure a rescue plan has been developed for all activities;

h. Specify in the fall protection and prevention plan, the fall protection systems, anchorage locations, connecting means, body supports and other equipment that End Users are required to use when exposed to a fall hazard;

i. Supervise the selection, installation, use and inspection of non-certified anchorages;

j. Verify End Users who work at heights are trained and authorized to do so;

k. Review, periodically and as needed, fall protection and prevention plan/rescue plan and procedures, to insure the End User is adequately informed about the fall protection and prevention plan/rescue plan and procedures for workplace activities;

l. Ensure prompt rescue of End Users can be accomplished via the rescue plan and procedures to be used;

m. Participate in investigation of all mishaps related to falls from heights;

n. Ensure all damaged or deployed fall protection equipment, is removed from service immediately;

o. Inspect all fall protection equipment at the frequency required by the manufacturer.



21.B.04 End User. The End User shall have understanding of workplace activities and follow the policy and procedures and the instructions of the CP regarding the use of fall protection and rescue systems and equipment. >See Section 21.C for training requirements. The End User shall:

- a. Bring all unsafe or hazardous conditions or actions that may cause injury to them or others, to the attention of the CP;
- b. Properly use, inspect, maintain, store and care for their fall protection equipment and systems;
- c. Inspect all fall protection equipment or damage or defects, prior to each use. End User shall notify the CP of those problems and shall not use that equipment.

21.B.05 Competent Rescuer. The Competent Rescuer is responsible for anticipating the potential for planned rescue and ensuring effective rescue plan/procedures and methods are in place before End Users starts any work at heights. This function may be performed by local emergency services, in-house professionals, competent or qualified persons or contractor services. In addition, they shall:

- a. Be trained appropriately so they have a working knowledge through experience and training of current fall protection and planned rescue regulations, standards, equipment and systems. > See Section 21.C for all training requirements;
- b. Prepare, update, review and approve the rescue plan and procedures before End Users start work at heights;
- c. Verify all Authorized Rescuers have been adequately trained and are proficient at performing rescue;
- d. Identify resources necessary to conduct safe, effective rescue from heights and verify those resources are available for a prompt rescue;
- e. Know the hazards associated with rescue from heights and how to mitigate these hazards within the area of rescue;
- f. Verify the rescue equipment is protected against damage;
- g. Verify rescue plans, procedures, and performances are, at a minimum, evaluated annually and any deficiencies have been corrected.

21.B.06 Authorized Rescuer. The Authorized Rescuers is responsible for performing and/or assisting in workplace rescues for personnel suspended in, or attached to fall protection systems. They shall:

- a. Through experience and training, have a working knowledge of and experience in the selection, use, storage and care of all equipment necessary to perform a rescue;
- b. Inspect the rescue equipment according to procedures developed by the Competent Rescuer and ensure it is protected, in proper working condition, and safe for rescue use;
- c. Trained to the appropriate level and shall be aware of the hazards that may endanger the rescuer during rescue operations. >See Section 21.C for Authorized Rescuer training requirements.

#### 21.C Training.

21.C.01 Training of all personnel involved in the Fall Protection Program – The Program Manager, QPs, CPs, End Users, Authorized and Competent Rescuers, as well as any associated fall protection trainers – shall be as described in ANSI/ASSE Z359.2, Minimum Requirements for a Comprehensive Managed Fall Protection Program, and shall conform to ANSI/ASSE Z490.1, Criteria for Accepted Practices in Safety, Health and Environmental Training. The refresher for all personnel involved in the fall protection program shall also be in accordance with requirements prescribed in ANSI/ASSE Z359.2 standard.

21.C.02 Fall Protection Program Manager Training. Training for Program Managers shall be conducted by a CP Trainer or QP Trainer.

a. Program Managers shall have a working knowledge of current fall protection regulations, requirements, standards, equipment and systems. Training shall cover the items prescribed in ANSI/ASSE Z359.2 standard.

b. For USACE-owned and/operated permanent facilities, Program Managers shall complete refresher training annually, by participating in at least one (1) hour of fall protection and rescue-related informational meetings and/or training.

21.C.03 Qualified Person for Fall Protection. A QP shall be trained by a QP Trainer in proper inspection, assembly and use of all fall protection equipment and systems that they encounter in their work as a QP. The frequency and duration of training that a QP requires to remain proficient in that role varies with the amount and types of fall protection work for which that person is responsible.

a. QPs are responsible for performing various duties that may be critical to the life and health of other workers. Training shall include those items in ANSI /ASSE Z359.2 standard, and shall include hands-on use of all types of equipment and systems used in locations where End Users work, to include: inspecting the systems prior to use; installing systems; analyzing structures and verifying that fall protection systems are properly installed; determining component compatibility; estimating free fall distances; determining total required clearance; dismantling systems storing equipment and common hazards associated with each system component.

b. For USACE-owned/operated permanent facilities, the refresher training requirement for the QPs is to stay current with fall protection and rescue knowledge by participating in at least one (1) hour annually of fall protection and rescue-related training and/or informational meetings.

21.C.04 Competent Person for Fall protection. CP shall be trained by a Competent Person trainer or a Qualified Person Trainer (see ANSI/ASSE Z359.2).

a. Currently, CPs shall have been trained to the level necessary to safely perform their duties.

➤ Note: Eighteen (18) months from the effective date of this manual, acceptable Competent Person for Fall Protection training shall be a MINIMUM of 24 hours, with a combination of formal classroom training and practical applications. All training shall be documented.

b. For USACE-owned/operated permanent facilities, the refresher training requirement for the CPs is to stay current in fall protection and rescue knowledge by participating in at least two (2) hours annually of fall protection and rescue-related training and/or informational meetings.

21.C.05 End User. Each worker who might be exposed to fall hazards from heights, shall be trained before using fall protection equipment by a CP, who is qualified in delivering fall protection training to the workers in the safe use of fall protection systems/equipment and the recognition of fall hazards related to their use, including:

- a. The nature of fall hazards in the work area;
- b. The correct procedures for erecting, using, dismantling, inspecting, maintaining, and storing fall protection equipment;
- c. The application limits, free fall distance, total fall distance and clearance requirements of fall protection systems and equipment;
- d. Rescue equipment and procedures;

e. Hands-on training and practical demonstrations;

f. Proper anchoring and tie off techniques;

g. All applicable requirements from this Section.

h. Refresher training shall be provided as necessary for the end users in the following situations:

(1) Changes in the fall protection program render previous training obsolete;

(2) Changes in fall protection or rescue equipment render previous training obsolete;

(3) Inadequacies in an employee's performance indicate a lack of knowledge or skill;

(4) A condition in the workplace changes in a manner that could affect the safe use of the fall protection equipment.

i. For USACE-owned/operated permanent facilities, the refresher training for end users shall be provided a minimum of one (1) hour annually to stay current with fall protection and rescue requirements.

21.C.06 Competent Rescuer. The Competent Rescuer shall be trained by a Competent Rescue Trainer (see ANSI/ASSE Z359.2). The training shall include:

a. Safe use of all types of equipment and systems used for rescue including inspection of the systems prior to use, installation, component compatibility, descent control, back-up systems, dismantling, storage and the common hazards associated with each system;

b. Practical demonstrations on how to properly select, inspect, anchor, assemble and use the fall protection and rescue equipment used;

c. For USACE-owned/operated permanent facilities, the refresher training for Competent Rescuers shall be provided a minimum of one (1) hour annually to stay current with fall protection and rescue requirements.

21.C.07 Authorized Rescuer. The Authorized Rescuer shall be trained by a Competent Rescuer (see ANSI/ASSE Z359.2). The training shall:

a. Be received before exposure to a fall hazard or a potential rescue event;

b. Include practical demonstrations on how to properly select, inspect, anchor, assemble, disassemble, store and use the fall protection and rescue equipment used.

c. Include and demonstrate before-use inspection of rescue equipment and systems.

d. For USACE-owned/operated permanent facilities, the refresher training for authorized rescuers shall be provided a minimum of one (1) hour annually to stay current with fall protection and rescue requirements.

21.C.08 Documentation. Training and evaluations for fall protection and rescue training shall be documented and retained for the current and previous training program and shall include: trainer/evaluator's name, student's name, training or evaluation organization's name (if external), dates/times of training and evaluations, course objectives, content of training program, performance of student based on observation of physical demonstrations of skill or on exercises.

#### 21.D Fall Protection Program.

21.D.01 If a Contractor will have personnel working at heights and/or exposed to fall hazards, a Fall Protection and Prevention Plan shall be developed and submitted to the GDA for review and acceptance as part of their Accident Prevention Plan (APP). This plan may be developed by either the CP or QP. If the plan includes fall protection components or systems requiring direction, supervision, design calculations or drawings by a QP, the name, qualifications and responsibilities of the QP shall be addressed. It shall describe, in detail, the specific practices, equipment and control methods used to protect workers from falling to lower levels. This plan shall be updated as conditions change, at least every six months and shall include:

a. Duties and responsibilities. Identify CPs and QPs and their responsibilities and qualifications;

b. Description of the project or task performed;

c. Training requirements to include safe use of fall protection equipment;

d. Anticipated hazards and fall hazard prevention and control;

e. Rescue plan and procedures;

f. Design of anchorages/fall arrest and horizontal lifeline systems:

(1) It is realized that the provision of fall protection for the first person up for establishing anchorages ONLY would be difficult. In this situation, fall protection may not be required. After anchorages are installed, fall protection is required.

(2) The contractor shall identify all locations where anchorages need to be established, and detail in the Fall Protection and Prevention Plan and AHA how work will be performed safely.

- g. Inspection, maintenance and storage of fall protection equipment;
- h. Incident investigation procedures;
- i. Evaluation of program effectiveness, and
- j. Inspection and oversight methods employed.

21.D.02 Each Government-owned facility shall develop a written Fall Protection Program if they have personnel working at heights. The facility shall also develop a Site Specific Fall Protection and Prevention Plan and conduct a fall hazard survey, prepare survey report at existing buildings or structures, and comply with the program elements and requirements as identified in this section.

21.E Controlled Access Zones. The use of Controlled Access Zone as a fall protection method is prohibited.

21.E Fall Protection Systems.

21.E.01 Standard Guardrail Systems.

- a. For marine and floating plant guardrail systems, see Sections 19.C, D and E.
- b. A standard guardrail shall consist of:

(1) Toprails, midrails, and posts, and shall have a vertical height of 42 +/- 3 in (106.6 cm +/- 7.6 cm) from the upper surface of the toprail to the floor, platform, runway, or ramp level;

(2) Midrails shall be erected halfway between the toprails and the floor, platform, runway, or ramp;

(3) The ends of the toprails and midrails shall not overhang the terminal posts except where such overhang does not create a projection hazard;

(4) Toe-boards shall be provided on all open sides/ends at locations where persons are required or permitted to pass or work under the elevated platform or where needed to prevent persons and material from falling from the elevated platform.

c. Strength requirements: toprails and midrails shall be designed to meet the following requirements:

(1) Toprail shall be capable of withstanding, without failure, a force of at least 200 lb (0.9 kN) applied within 2 in (5 cm) of the top edge, in any outward or downward direction, at any point along the top edge;

(2) When the force described in (1), above, is applied in a downward direction, the top edge of the top rail shall not deflect more than 3 in (7.6 cm) nor to a height less than 39 in (99 cm) above the walking/working level;

(3) Midrails, screens, mesh, intermediate vertical members, solid panels, and equivalent structural members shall be capable of withstanding, without failure, a force of at least 150 lb (666 N) applied in any downward or outward direction at any point along the midrail or other member;

(4) Guardrail systems shall be so surfaced as to prevent injury to a worker from punctures or lacerations and to prevent snagging of clothing.

d. Minimum construction materials for standard guardrail components. The following are minimum requirements used for constructing guardrail systems. The employer is responsible for designing a complete system and assembling these components in accordance with this Section.

➤ Note 1: Synthetic or natural fiber ropes shall not be used as top rails or midrails.

➤ Note 2: Wood railing components shall be minimum 1,500 lb-ft/in<sup>2</sup> fiber (stress grade) construction grade lumber.

(1) Wood railings:

(a) Top rails: Constructed of at least 2-in x 4-in (5-cm x 10-cm) lumber;

(b) Midrails: Constructed of at least 1-in x 6-in (2.5-cm x 15.2-cm) lumber; and,

(c) Posts: Constructed of at least 2-in x 4-in (5-cm x 10-cm) lumber spaced not to exceed 8 ft (2.4 m) on centers.

(2) Pipe railings:

(a) Top rails and midrails: At least 1 ½ in (3.8 cm) nominal diameter (schedule 40 steel pipe); and

(b) Posts: At least 1 ½ in (3.8 cm) nominal diameter (schedule 40 steel pipe) spaced not more than 8 ft (2.4 m) on centers.

(3) Structural steel railings:

- (a) Toprails and midrails: At least 2-in x 2-in x 3/8 in (5 cm x 5 cm x .9 cm) angles, and,
- (b) Posts: At least 2-in x 2-in x 3/8-in (5 cm x 5 cm x .9 cm) angles spaced not more than 8 ft (2.4 m) on centers.

(4) Steel Cable (Wire Rope) railings:

(a) Toprail and midrail: ¼ in (6.25 mm) steel cable, flagged every 6 ft (1.8 m) with high visibility material, may be used if tension is maintained to provide not more than 3 in (7.5 cm) deflection, in any direction from the center line, under a 200 lb (0.89 kN) load;

(b) Support posts shall be located to ensure proper tension is maintained;

(c) Perimeter safety cables shall meet the criteria and requirements for guardrail systems. If the perimeter safety cables are used by the workers as a method of attaching a lanyard to the cables they shall meet the requirements of Horizontal Lifeline System (see Section 21.1.08.d.(2)).

e. Commercial, off-the-shelf (COTS), engineered guardrail systems may be used instead of constructing a system with the materials above. If so, the portable guardrail system (webbing, straps, etc) must be designed and engineered to meet the same requirements in this section. The employer is still responsible for insuring the system used is approved, completed, installed and used as designed.

f. Toe-boards.

(1) Toe-boards shall be 3½ in (8.75 cm) in vertical height and shall be constructed from 1-in x 4-in (2.5-cm x 10.1-cm) lumber or the equivalent.

(2) Toe-boards shall be securely fastened in place and have not more than ¼ in (0.6 cm) clearance above floor level.

(3) Toe-boards shall be made of any substantial material, either solid or with openings between adjacent pieces not greater than 1 in (2.5 cm).

(4) Where material is piled to such a height that a standard toe-board does not provide protection, paneling or screening from floor to toprail or midrail shall be provided.

(5) Toe-boards shall be able to withstand, without failure, a force of 50 lbs (0.22 kN) applied in any outward or downward direction at any point along the toe-board.

21.E.02 Guardrails receiving heavy stresses from workers trucking or handling materials shall be provided additional strength by using heavier stock, closer spacing of posts, bracing, or by other means.



EM 385-1-1  
30 Nov 14

21.F.03 When guardrails are used at hoisting areas, a minimum 6 ft (18. m) of guardrail shall be erected on each side of the access point through which materials are hoisted.

21.F.04 A gate or removable guardrail section may be used as long as it meets the standard guardrail height 42 +/- 3 in (106.6 +/- 7.6 cm) and is secured across the opening between the guardrail sections when hoisting operations are not taking place.

21.F.05 Existing parapet walls. In order for parapet walls to be considered adequate fall protection systems, they shall have a height of 42 in +/- 3 in (1 m +/- 7.6 cm) unless it is an EXISTING parapet walls with a height of less than 42 in (1 m). If so, the EXISTING parapet wall may be used as a compliant fall protection system if the vertical height is a minimum of 30 in (76 cm) or more plus width that equals to 48 in (1.2 m). > See Figure 21-2.

21.G Covers.

21.G.01 Install covers on any hole 2 in (5.1 cm) or more in its least dimension on walking/working surfaces such as floors, roofs or other openings.

21.G.02 Covers shall be capable of supporting, without failure, at least twice the weight of the worker, equipment and material combined.

21.G.03 Covers shall be secured when installed, clearly marked with the word "HOLE", "COVER" or "Danger, Roof Opening-Do Not Remove" or color-coded or equivalent methods (e.g., red or orange "X"). Workers must be made aware of the meaning for color coding and equivalent methods.

FIGURE 21-2

Existing Parapet Wall Used as a Fall Protection System

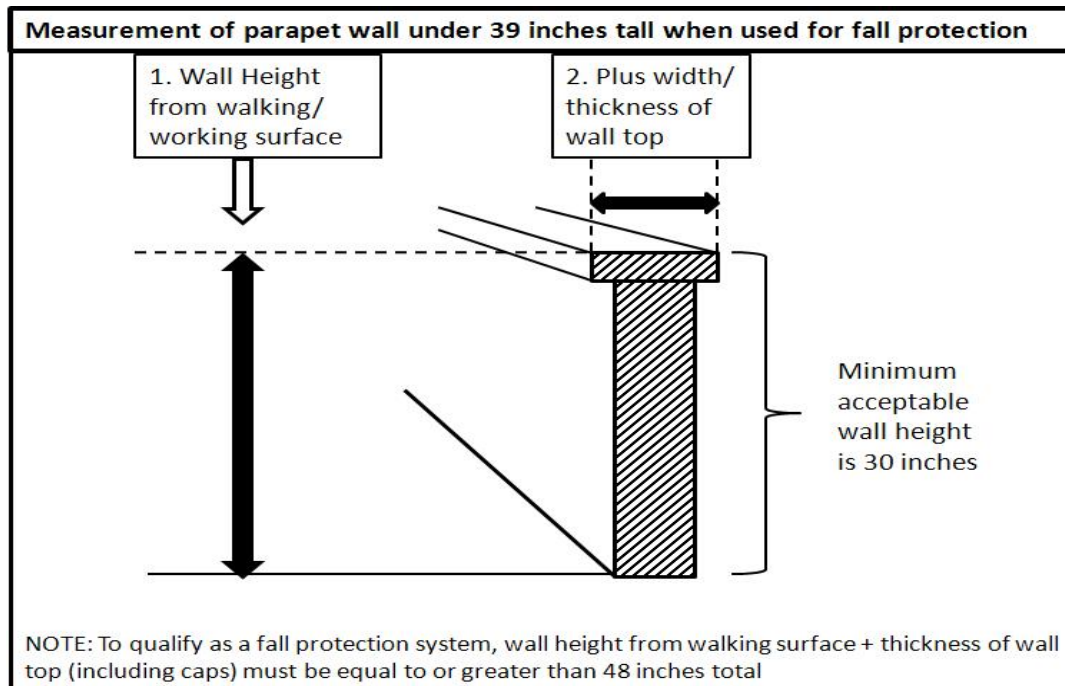

Any combination of 30 in (76 cm) or more in height plus width that equals 48 in (1.2 m) or more is acceptable.

21.H Safety Net Systems for Fall Protection.

➤ Debris nets are addressed in Section 14.E Housekeeping.

21.H.01 Safety nets shall be installed as close under the work surfaces as practical but in no case more than 30 ft (9.1 m) below such work surface. Nets shall be hung with sufficient clearance to prevent contact with the surfaces or structures below. Such clearance shall be determined by impact load testing. When nets are used on bridges, multi-story buildings or structures, the potential fall area from the walking/working surface to the net shall be unobstructed.

a. The maximum size of the mesh openings shall not exceed 36 in<sup>2</sup> (230 cm<sup>2</sup>), nor be longer than 6 in (15 cm) on any side.

b. The border rope or webbing shall have a minimum breaking strength of 5,000 lb (22.2 kN).

21.H.02 Nets shall extend outward from the outermost projection of the work surface as shown in Table 21-1.

21.H.03 Operations requiring safety net protection shall not be undertaken until the net(s) is in place and has either been tested without failure per a. and b. below, or complies with c. below.

a. Safety nets and safety net installations shall be tested in the suspended position immediately after installation under the supervision of QP and in the presence of the GDA and before being used as a fall protection system; whenever relocated, after major repair; and when left at one location, at not more than 6 month intervals.

b. The test shall consist of dropping into the net a 400 lb (180 kg) bag of sand, not more than 30 in+/- 2 in (76.2 cm +/- 5 cm) in diameter, at least 42 in (106.6 cm) above the highest working/walking surface at which workers are exposed to fall hazards. Means must be taken to ensure the weight can be safely retrieved after the test is conducted.

c. If a QP can demonstrate in writing that it is unreasonable to perform the drop-test, the QP shall certify in writing that the net and installation (to include anchorages) is in compliance with all requirements for acceptance by the GDA. The certification must include an identification of the net and net installation, the date that it was determined, and the signature of the QP making the determination and certification. The certification shall remain at the job-site.

TABLE 21-1

Safety Net Distances

Vertical Distance from Working Level to Horizontal Plane of Net	Minimum Required Horizontal Distance of Outer Edge of Net from Edge of Working Surface
Up to 5 ft (up to 1.5 m)	8 ft (2.5 m)
5 ft up to 10 ft (1.5 m up to 3.1 m)	10 ft (3.1 m)
more than 10 ft (more than 3.1 m)	13 ft (4 m)

21.H.04 Shackles and hooks used in safety net installations shall be made of forged steel.

21.H.05 When used with safety nets, debris nets shall be secured on top of the safety net but shall not compromise the design, construction, or performance of the safety nets.

21.H.06 Materials, scrap pieces, equipment, and tools that have fallen into the safety net shall be removed as soon as possible and at least before the next work shift. Safety nets shall be protected from sparks and hot slag resulting from welding and cutting operations.

21.H.07 Inspection of safety nets.

a. Safety nets shall be inspected by a CP in accordance with the manufacturer's instructions and recommendations.

b. Inspections shall be conducted immediately after installation, at least weekly thereafter, and following any alteration, repair, or any occurrence that could affect the integrity of the net system. Inspections shall be documented.

c. If any welding or cutting operations occur above the net(s), noncombustible barriers shall be provided. The frequency of inspections shall be increased in proportion to the potential for damage to the nets.

d. Defective nets shall not be used. Defective components shall be removed from service and replaced.

21.I Personal Fall Protection Systems.

21.I.01 Personal fall protection equipment and systems (to include fall arrest, positioning and restraint) shall be used when a person is working at heights and exposed to a fall hazard.

21.I.02 Inspection of personal fall protection equipment. Personal fall protection equipment shall be inspected by the End User prior to each use to determine that it is in a safe working condition. A CP shall inspect the equipment at least once semi-annually and whenever equipment is subjected to a fall or impacted. Inspection by the CP shall be documented. Defective or damaged equipment shall be immediately removed from service and replaced. Inspection criteria shall include:

a. Harnesses, lanyards, straps and ropes: Check all components for cuts, wear, tears, damaged threads, broken or torn stitching, discoloration, abrasions, burn or chemical damage, ultraviolet deterioration and missing markings and/or labels.

b. Hardware: Check all components for signs of wear, cracks, corrosion and deformation.

21.I.03 Personal fall protection equipment shall be used, inspected, maintained and stored in a safe place in accordance with manufacturer's instructions and recommendations or as prescribed by the CP.

21.I.04 Selection of personal fall protection equipment shall be based on the type of work being performed; the work environment; the weight, size, and shape of the worker; the type and position/location of anchorage; and the required length of the lanyard.

EM 385-1-1  
30 Nov 14

21.1.05 Personal Fall Arrest System (PFAS) consists of full body harness, connecting means, and an anchorage system.

➤ Note: All PFAS shall meet the requirements contained in ANSI Z359, Fall Protection Code, to include fall restraint and positioning systems.

a. PFAS are generally certified for users within the capacity range of 130 to 310 lbs (59 to 140.6 kg) including the weight of the worker, equipment and tools.

(1) Workers shall not be permitted to exceed the 310 lbs (140.6 kg) limit unless permitted in writing by the manufacturer.

(2) For workers with body weight less than 130 lbs (59 kg), a specially designed harness and also a specially designed energy absorbing lanyard shall be utilized which will properly deploy if this person was to fall.

b. When stopping a fall, PFAS shall:

(1) Limit maximum arresting force on the body of the employee to 1,800 lbs (8.0 kN) when used with a full body harness;

(2) Be rigged such that a worker can neither free fall more than 6 ft (1.8 m) nor contact any lower level or other physical hazard in the path of the fall. The free fall distance of 6 ft (1.8 m) can be exceeded if the proper energy absorbing lanyard is used.

c. When designing new PFAS, the QP shall attempt to minimize fall distances including free fall distances and arrest forces. > See Figure 21-3. If it is necessary to increase free fall distances and arrest forces in order to accommodate existing and new structures or provide mobility to end users:

(1) Only the QP shall make this determination; and

(2) The maximum arrest force shall be kept below 1,800 lbs (8.0 kN).

21.1.06 PFAS – Body Support.

a. Full Body Harness. PFAS require the use of a full-body harness. The use of body belts is prohibited.

(1) Only full body harnesses meeting the requirements of ANSI Z359 are acceptable. Full body harnesses labeled to meet the requirements of the ANSI A10.14 shall not be used.

(2) The fall arrest attachment point on the full body harness shall be integrally attached and located at the wearer's upper back between the shoulder blades (dorsal D-ring).

➤ Note: A frontal D-ring attachment point integrally attached to wearer's full body harness and located at the sternum, can be used for fall arrest (i.e., used with a ladder climbing device), provided the free fall distance does not exceed 2 ft (0.6 m) and the maximum arresting force does not exceed 900 lbs (4 kN).

(3) All full body harnesses shall be equipped with Suspension Trauma Preventers such as stirrups, relief steps, or similar in order to provide short-term relief from the effects of orthostatic intolerance.

b. Lineman's equipment (electrically rated harnesses). The full body harness used around high voltage equipment or structures shall be an industry designed "linemen's fall protection harness" that will resist arc flash and shall meet ASTM F887 and ANSI Z359 and the equipment must bear a label or similar stating such.

FIGURE 21-3

Calculating Fall Distance

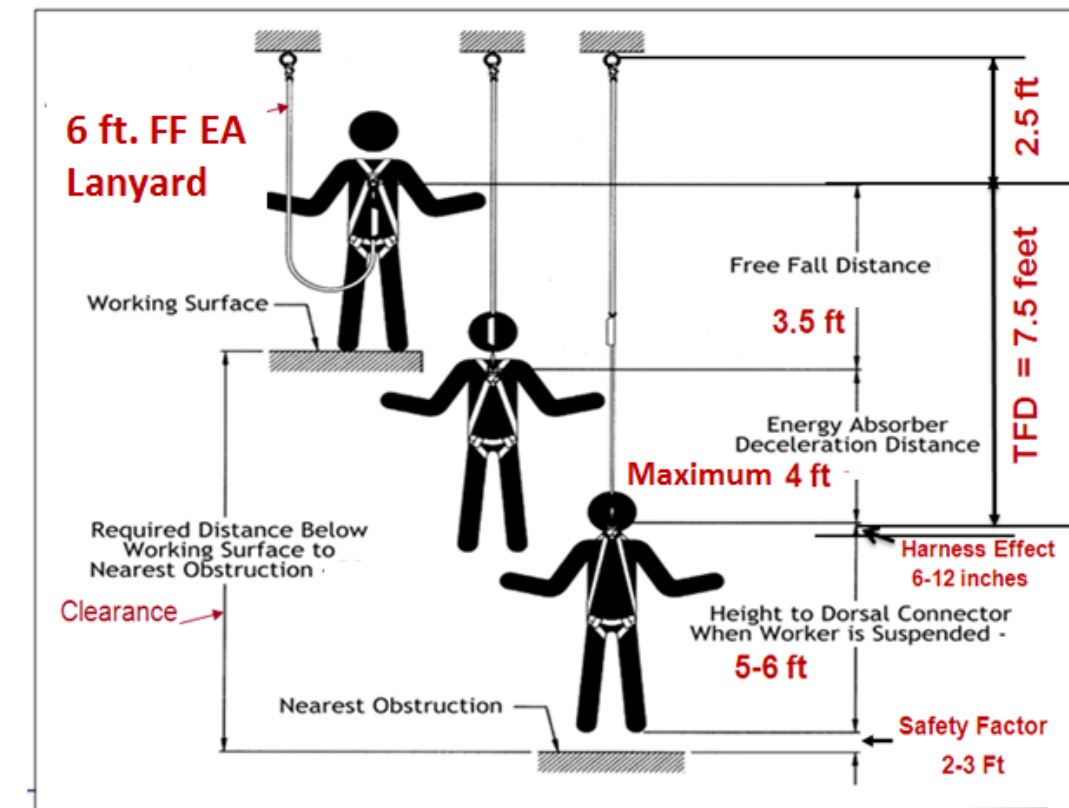

21.1.07 PFAS – Connecting Means. Connecting subsystems may include energy absorbing lanyards (shock absorbing lanyards) with snap hooks or carabiners at each end, self-retracting devices (SRDs), and/or fall arrestors (rope grabs).

a. Lanyards - General. Lanyards shall be made of ropes, straps or webbing made from synthetic materials. Energy absorbing lanyards, (including rip stitch/tearing and deforming lanyards) shall be capable of sustaining a minimum tensile load of 5,000 lbs (22.2 kN). The maximum length of single or “Y” lanyards used in fall arrest shall not exceed 6 ft (1.8 m).

(1) The 6 ft (1.8 m) Free Fall (FF) energy absorbing lanyard shall only be used when the tie-off point is above the dorsal D-ring creating a FF distance of less than 6 ft. The energy absorber shall have an average arrest force of 900 lbs (4 kN) and a maximum deployment distance of 4 ft (1.2 m). > See ANSI Z359.13, Par 3.1.8.1.

(2) When an anchor point is below the dorsal D-ring, a FF distance greater than 6 ft (1.8 m) is created. For these situations, a 12 ft (3.6 m) FF energy absorbing lanyard shall be used in accordance with manufacturer’s instructions and recommendations. The energy absorber shall have an average arrest force of 1,350 lbs (6 kN) and the maximum deployment distance of 5 ft (1.5 m). > See ANSI Z359.13, Par 3.1.8.2.

➤ Note: A 12 ft (3.6 m) FF energy absorbing lanyard does not refer to the lanyard length. Instead it refers to a FF that is greater than 6 ft (1.8 m) up to 12 ft which is created by the anchor point being located below the dorsal D-ring. The maximum length of the lanyard used shall not exceed 6 ft. > See Figure 21-4.

(3) The 6 ft (1.8 m) and 12 ft (3.6 m) FF energy absorbing lanyards shall meet the requirements of ANSI Z359.13 Standard.

➤ Note: Lanyards shall not be looped back over or through an object and then attached back to themselves unless permitted by the manufacturer.

b. “Y” Lanyards. When using lanyard with two integrally connected legs for 100% tie-off, attach only the snap hook at the center of the lanyard shall be attached to the fall arrest attachment element of the harness (D-ring).

(1) The two legs of the lanyard and the joint between the legs shall withstand a force of 5,000 lbs (22.2 kN).

(2) When one leg of the lanyard is attached to the anchorage, the unused leg of the lanyard shall not be attached to any part of the harness except to attachment points specifically designated by the manufacturer for this purpose.

FIGURE 21-4

6 ft Free Fall and 12 ft Free Fall Energy Absorbing Lanyard Labels

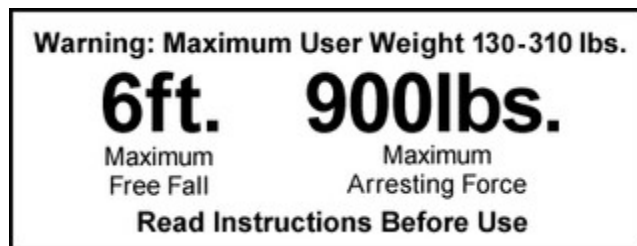

(3) The 6 ft (1.8 M) FF “Y” lanyard shall only be used when the tie-off point is above the dorsal D-ring height and when the FF distance is less than 6 ft.

(4) When the tie-off point is located below the dorsal D-ring, the FF distance is greater than 6 ft (1.8 m) so a 12 ft (3.6 m) FF “Y” lanyard may be used.

➤ Note: A 12 ft (3.6 m) FF energy absorbing “Y” lanyard does not refer to the lanyard length. Instead it refers to a FF that is greater than 6 ft (1.8 m) up to 12 ft which is created by the anchor point being located below the dorsal D-ring. The maximum length used shall not exceed 6 ft.

(5) The maximum arrest force on the body shall not exceed 1800 lbs (8 kN).

(6) The 6 ft (1.8 m) and 12 ft (3.6 m) FF energy absorbing “Y” lanyards shall meet ANSI/ASSE Z359.13 standard.

➤ Note: Effective 2 years from date of publication, all energy absorbers used shall be equipped with a deployment indicator.

c. Hardware (connecting components).

(1) Snap hooks and carabiners shall be self-closing and self-locking, capable of being opened only by at least two consecutive deliberate actions. Snap hooks and carabiners having minimum gate strength of 3,600 lbs (16 kN) in all directions, per ANSI Z359.12 shall be used.



(2) Snap hooks and carabiners shall have a minimum tensile strength of 5,000 lbs (22.2 kN); D-rings, O-rings, snap hooks and carabiners shall be capable of withstanding a tensile load of 5,000 lbs.

(3) Connectors, adjusters, and any buckles used as adjusters shall be capable of withstanding a minimum tensile load of 3,372 lbs (15 kN) and shall be made of drop forged, pressed or formed steel, or made of equivalent materials; shall have corrosion resistant finish; and all surfaces and edges shall be smooth to prevent damage to interfacing parts of the system.

(4) All connecting components used in PFAS shall be compatible and shall be used properly.

d. Self Retracting Devices (SRDs). The SRDs shall meet the requirements of the ANSI/ASSE Z359.14 standard.

(1) A Self-retracting lanyard (SRL) is a device mounted or anchored such that the arrest distance shall not exceed 2 ft (60 cm), and the average arrest force shall not exceed 1,350 lbs (6 kN) or a maximum peak force of 1,800 lbs (8 kN). The SRL is only used for vertical applications.

(2) An SRL with leading edge capability (SRL-LE) is designed for applications where during use, the device is not necessarily mounted or anchored overhead and may be at foot level and where the possible free fall distance from the edge is up to 5 ft (1.5 m) and the average arrest distance shall not exceed 4.5 ft (1.37 m). The device is equipped with an energy absorber to withstand impact loading of the line with a sharp or abrasive edge during fall arrest and for controlling fall arrest forces on the worker.

➤ Note: Effective 2 years from date of publication, all SRDs used shall be equipped with visual indicator.

e. Fall arrestors (rope grabs) designed to be used with a vertical lifeline and ladder climbing devices (rope, cable or rail) shall be approved by the manufacturer for such use. Fall arresters shall have a minimum ultimate strength of 3,600 lbs (16 kN).

➤ Note: For vertical lifelines or ladder climbing devices, use the automatic fall arrestors that move in one direction only.

21.1.08 PFAS - Anchorage System. The anchorage system consists of the anchorage (the rigid part of the building, facility, structure or equipment) and the anchorage connector.

a. Anchorages used for attaching the PFAS shall be independent of any anchorage used to support or suspend platforms. They shall be capable of supporting at least 5,000 lbs (22.2 kN) per worker attached or designed by a QP for twice the maximum arrest force on the body.

b. Anchorage connectors are used to tie the PFAS to the anchorage and shall be capable of withstanding without breaking 5,000 lbs (22.2 kN) load per worker attached.

c. Steel cable/wire rope guardrails may not be used as a Horizontal Life Line (HLL) unless designed and approved by a QP.

➤ Note: Do not use electric conduits, utility pipes, ductwork or unstable points as anchorages for PFAS.

d. Lifelines.

(1) Vertical lifeline (VLL). A VLL shall have a minimum tensile strength of 5,000 lbs (22.2 kN) attached to a single overhead anchorage. Each worker shall be attached to a separate lifeline system.

(2) Horizontal lifeline (HLL).

(a) Locally manufactured HLLs are not acceptable unless they are custom designed for limited or site specific applications by a Registered Professional Engineer (RPE) who is also qualified in designing HLL systems.

(b) Commercially manufactured HLLs shall be designed, installed, certified and used under the supervision of QP only, as part of a complete fall arrest system. The CP may (if deemed appropriate by QP), supervise the assembly, disassembly, use and inspection of the HLL systems, under the direction of the QP.

(c) The design shall include drawings, required clearance, instructions on proper installation, and use procedures, proof testing reports and inspection requirements.

(d) All HLL anchorages shall be designed by a RPE who is also qualified in designing HLL systems. > See ANSI/ASSE Z359.6.

(e) The design of all HLLs shall be reviewed and accepted by the GDA as part of the Fall Protection and Prevention Plan.

21.1.09 Positioning System. A positioning system uses some of the same equipment as a fall protection system (i.e., a harness, etc.), however, a positioning system used alone does not constitute fall protection.

a. A positioning system shall not be used as a primary fall arrest system. While positioning (working with both hands free), a person shall use a separate system that provides back-up protection from a fall.

b. System requirements. Positioning System shall:

(1) Be rigged such that a worker cannot free fall more than 2 ft (0.6 m);

(2) Be secured to an anchorage capable of supporting at least twice the potential impact load of a worker's fall or 3,000 lbs (13.3 kN), whichever is greater;

(3) Ensure workers achieve 100% tie-off during use;

(4) The attachment points on the full body harness used in the positioning system shall be located on the sides or on the front of the harness.

#### 21.I.10 Restraint Systems.

a. Consideration shall be made for use of fall restraint over fall arrest. Fall restraint systems prevent the user from reaching an area where a free fall could occur by restricting the length of the lanyard or by other means.

b. The anchorage strength requirement for restraint systems shall be 3,000 lbs (13.3 kN) or designed by a QP for two times the foreseeable force.

c. Restraint systems can be used only on flat or low-sloped surfaces ( $\leq 18.4^\circ$  or 4:12 slope).

21.J Ladder-Climbing Devices (LCDs). A LCD is a sleeve or cable/rope attached to a fixed ladder over 20 ft (6 m) in length.

21.J.01 Anchorage strength for LCDs shall be a minimum of 3,000 lbs (13.3 kN).

21.J.02 The connector between the front D-ring of the harness and the ladder cable, rope or sleeve shall be 9 in (20 cm) long.

21.J.03 The free fall distance when using a LCD shall not exceed 2 ft (0.6 m).

21.J.04 There shall be 100% transition at the top of the LCD for safe access to above work surface or roof.

➤ Note: Do not install LCDs on ladders that have  $\frac{3}{4}$  in (1.9 cm) rungs (off- the-shelf-ladders) unless the ladders are designed to withstand the fall forces.

21.K Scaffolds, Work Platforms and Elevating/Aerial Devices.

21.K.01 Scaffolds shall be equipped with a standard guardrail per 21.F.01 or other fall protection systems.

21.K.02 For workers erecting and dismantling scaffolds, an evaluation shall be conducted by a CP to determine the feasibility and safety of providing fall protection if fall protection is not feasible. An AHA detailing rationale for infeasibility of use of fall protection shall be submitted and accepted by the GDA.

21.K.03 Suspended scaffolds.

a. Single point or two point suspended scaffold: In addition to railings, workers shall also be tied off to an independent vertical lifeline using a full body harness.

b. Other suspended scaffolds (e.g. catenary, float, needle-beam, Boatswain chairs): PFAS is required and workers shall be tied off to an independent vertical lifeline using a full body harness.

c. A risk assessment shall be performed when persons are supported on a multi-point adjustable suspended scaffold to evaluate the effectiveness and feasibility of the use of PFAS. Results shall be documented in the AHA for the activity being performed. > See 21.I.05.

21.K.04 Self-Propelled Elevating Work Platforms (Scissor Lifts), per ANSI A92.6.

a. Scissor lifts shall be equipped with standard guardrails.

b. In addition to the guardrail provided, the scissor lift shall be equipped with anchorages meeting the ANSI Z359 Fall Protection Code.

➤ Note: Scissor lifts not equipped with anchorages are prohibited.

c. A restraint system shall be used in addition to guardrails. The lanyards, to include lanyards with built-in shock absorbers, used with the restraint system shall be sufficiently short to prohibit workers from climbing out of, or being ejected from the platform.

d. The use of a self-retracting device (SRD) is prohibited unless permitted by the SRD manufacturer and used in accordance with manufacturer's instructions.

e. Workers are prohibited from climbing on or over the guardrails.

21.K.05 Aerial Work Platforms: Boom Supported Platforms (per ANSI A92.5) and Vehicle Mounted Rotating and Elevating Aerial Devices (per ANSI A92.2).

EM 385-1-1  
30 Nov 14

a. Workers shall be anchored to the basket or bucket in accordance with manufacturer's specifications and instructions (anchoring to the boom may only be used when allowed by the manufacturer and permitted by the CP).

b. Lanyards used shall be sufficiently short to prohibit worker from climbing out of basket.

c. Lanyards with built-in shock absorbers are acceptable.

d. Self-retracting devices are not acceptable.

e. Tying off to an adjacent pole or structure is not permitted unless a safe device for 100% tie-off is used for the transfer.

21.K.06 Manually Propelled Elevating Work Platforms (per ANSI/SIA A92.3). > See Section 22.C.06 for Mobile Scaffolds.

a. The platform shall be equipped with standard guardrails.

b. If the platform is equipped with anchorages meeting the ANSI Z359, a restraint system shall be used in addition to the guardrails.

c. Lanyards used with the restraint system shall be sufficiently short to prohibit workers from climbing out of, or being ejected from the platform.

d. Lanyards with built-in shock absorbers are acceptable.

e. Self retracting devices are not acceptable.

f. The platform shall not be occupied when moved and at no time will workers be allowed to climb on or over the guardrails. > See Figure 21-5.

FIGURE 21-5

Typical Examples of Manually Propelled Elevating Aerial Platforms

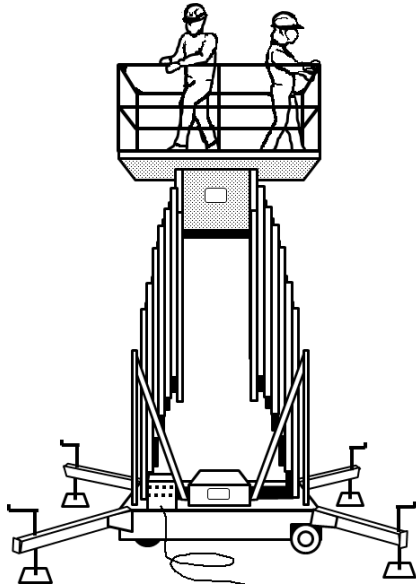

Example #1

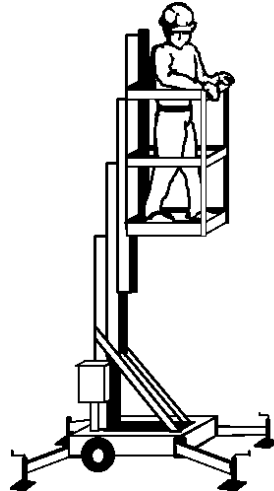

Example #2

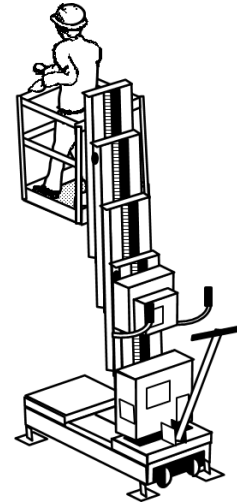

Example #3

21.L Warning Line System (WLS).

21.L.01 A WLS may ONLY be used on floors, or flat or low-sloped roofs (between 0-18.4° or less than 4:12 slope) during construction work and shall be erected around all sides of the work area.

21.L.02 A WLS shall consist of wires, rope or chains 34-39 in (0.9-1.0 m) high with supporting stanchions. WLS shall be flagged at not more than 6 ft (1.8 m) intervals with a high visibility material.

21.L.03 The wire, rope or chains shall have a minimum tensile strength of 500 lbs (2.2 kN) and after being attached to the stanchions shall be capable of supporting without braking, the loads applied to the stanchions.

EM 385-1-1  
30 Nov 14

21.L.04 Stanchions shall be capable of resisting without tipping a force of 16 lbs (71 N) applied horizontally against the stanchions 30 in (76.2 cm) above the walking/working surface, perpendicular to the warning line and in the direction of the roof floor or platform edge. The line consisting of wire rope or chains shall be attached at each stanchion in such a way that the pulling on one section of the line will not result in a slack being taken up in adjacent sections before the stanchion tips over.

21.L.05 Working within the WLS does not require fall protection. No worker shall be allowed in the area between the roof or floor edge and the WLS without fall protection. Fall protection is required when working outside the WLS.

21.L.06 Roofing Work.

a. For roofing work on flat roofs, the WLS shall be erected not less than 6 ft (1.8 m) from the edge.

b. When roofing work is conducted on low sloped roofs (less than 4:12), or when using mechanical equipment or when work is performed by other trades (i.e., mechanical contractor performing work on equipment located on roofs, etc), the WLS shall be erected not less than 15 ft (4.5 m) from the unprotected side or edge.

21.L.07 A Designated Area is used as a fall protection method during maintenance work (i.e., inspecting or maintaining HVAC equipment) on roofs. The requirement for the Designated Area is identical to WLS. In addition, a 100% transition is required from the access point on the roof to the Designated Area. > See Figure 21-6.

21.M Safety Monitoring System (SMS). The use of a SMS as a fall protection method is prohibited.

Figure 21-6  
Designated Area

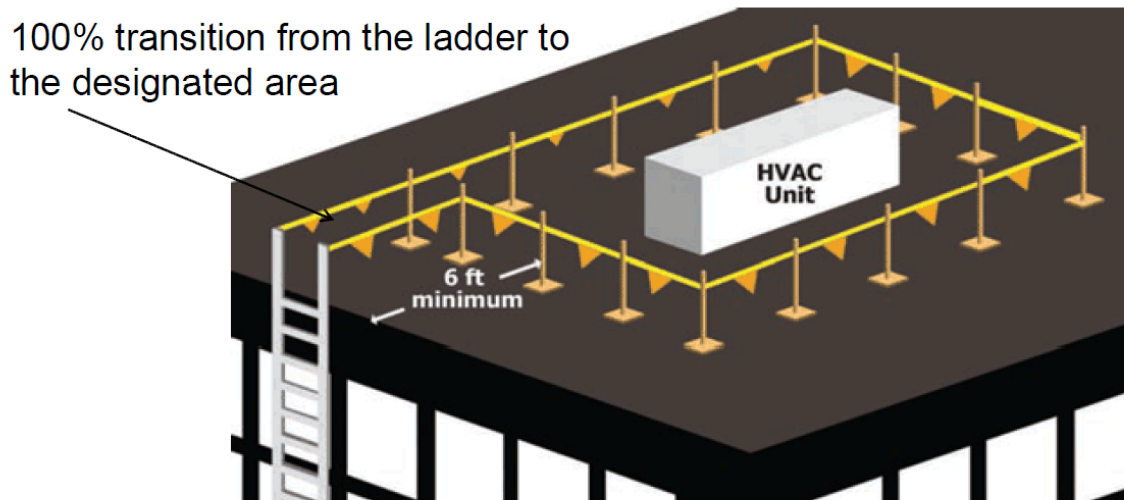

- Used on roofs during maintenance work – i.e., inspecting or maintaining HVAC equipment - (NOT roofing work)
- Similar to warning line system for construction (21.L)

21.N Rescue Plan and Procedures. The employer is required to provide prompt rescue to all fallen workers.

21.N.01 A rescue plan shall be prepared and maintained when workers are using fall protection equipment. > See ANSI Z359.2, Written Rescue Procedures.

21.N.02 The plan shall contain provisions for self-rescue and assisted rescue of any worker who falls including rescue equipment. If other methods of rescue are planned (i.e. a jurisdictional public or Government emergency rescue agencies), it shall be indicated in the rescue plan including how to contact and summon the agency to the mishap site.

21.N.03 Personnel conducting rescue shall be trained accordingly.

21.N.04 If required, anchorages for self-rescue and assisted-rescue shall be identified, selected, and documented in Site-Specific Fall protection and Prevention Plan. Anchorages selected for rescue shall be capable of withstanding static loads of 3,000 lbs (13.3 kN) or five times the applied loads as designed by a QP.



EM 385-1-1  
30 Nov 14

21.N.05 Workers using fall protection equipment shall have an assigned safety person (spotter) also known as the “buddy system”, who will be within visual/verbal range to initiate rescue of the fallen worker if required.

21.N.06 Rescue equipment used for self-rescue or assisted-rescue (i.e. SRL with rescue capability) shall meet ANSI Z359.4 and Z359.14.

21.Q Working Over or Near Water (piers, wharves, quay walls, barges, aerial lifts, crane-supported work platforms, etc). PFDs are required for all work over or near water unless detailed below. > See Figure 21-7.

➤ Note 1: All USACE and contractor workers, to include divers, shall comply with the requirements below.

➤ Note 2: If utilizing PFDs with full body harness, the full body harness shall be worn under the PFD. The type of PFD used shall not interfere with proper use of a full body harness and lanyard.

21.Q.01 When continuous fall protection is used, without exception, to prevent workers from falling into the water, the employer has effectively removed the drowning hazard and PFDs are not required.

➤ Note: When using safety nets as fall protection, USCG-approved PFDs are usually required, unless rationale is provided in AHA.

21.Q.02 When working over or near water and the distance from walking/working surface to the water’s surface is 25 ft (7.6 m) or more, workers shall be protected from falling by the use of a fall protection system and PFDs are not required.

21.Q.03 When working over or near water where the distance from the walking/working surface to the water’s surface is less than 25 ft (7.6 m) AND the water depth is less than 10 ft (3.05 m), fall protection shall be required and PFDs are not required.

21.Q.04 When working over water, PFD, lifesaving equipment and safety skiffs meeting the requirements of this EM shall be used as required.

21.Q.05 When working from/in machinery (mechanically operated equipment), aerial lift equipment or other movable work platforms/cranes directly over water AND the depth of the water is at least 10 ft (3 m) deep, fall protection is not required however, PFDs are required.

21.O.06 When there are hazards from currents, intakes, dangerous machinery or equipment, or barges, etc., fall protection shall be required regardless of the fall distance and PFDs are not required.

FIGURE 21-7

## Fall Protection (FP) vs. Personal Flotation Device (PFD) Use When Working Over or Near Water

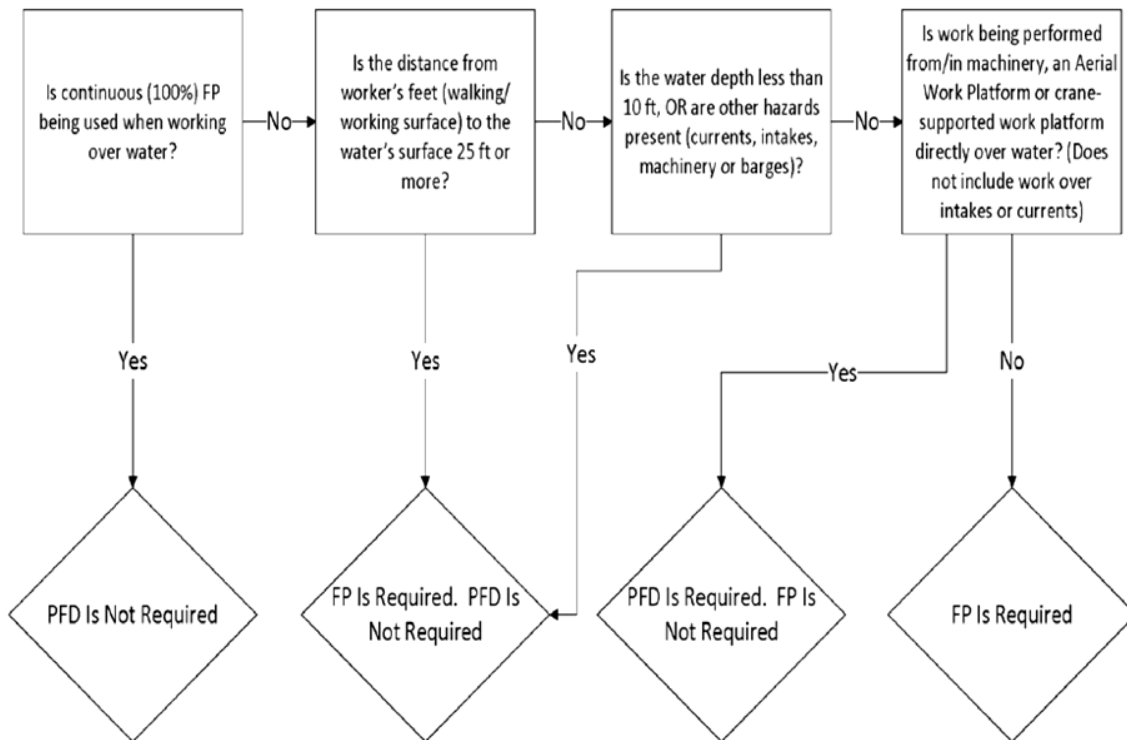

EM 385-1-1  
30 Nov 14

21.P Other Engineered Fall Protection Systems.

21.P.01 Commercially available engineered/integrated systems are recognized as effective fall protection and may be used. These are systems that are not addressed in Paragraph 21.F.

21.P.02 Commercially available engineered/integrated systems shall be designed, installed, certified and used only under the supervision of QP and used per manufacturer instructions and recommendations. The CP may (if deemed appropriate by a QP), supervise the assembly, disassembly, use and inspection of the engineered system, under the direction of the QP.

21.P.03 The design shall include drawings, required clearance, instructions on proper installation, use and inspection requirements. These systems shall be reviewed and accepted by the GDA as part of the Fall Protection and Prevention Plan.

THIS PAGE INTENTIONALLY LEFT BLANK