

SECTION 28

Steel Erection

28.A General. The fall protection threshold height requirement is 6 ft (1.8 m) for ALL work covered by this manual, unless specified differently below, whether performed by Government or Contractor work forces, to include steel erection activities and systems-engineered activities (prefabricated) metal buildings. > See *Section 21*.

28.A.01 Construction loads shall not be placed on a structure or portion of a structure unless the employer determines, based on information from a person who is qualified in structural design, that the structure or portion of the structure is capable of supporting the loads.

28.A.02 Employees shall not be permitted to work above or in positions exposed to protruding reinforcing steel, fasteners, or other impalement hazards unless provisions have been made to control the hazard.

28.A.03 No employee shall be permitted to work under bundled material loads or other suspended loads. Riggers securing lower loads to multi-lift rigging assemblies and workers setting suspended structural components such as beams, trusses, and precast members are excluded from this requirement. In these cases, work controls should be used to minimize the time spent directly under loads.

28.B Structural Steel Assembly.

28.B.01. Prior to beginning the erection of any structural steel, a Steel Erection Plan shall be submitted to the GDA for review and acceptance. The plan will include the identification of the site and project; and will be signed and dated by the Qualified Person (QP) responsible for its preparation and modification. This plan shall include the following information, as applicable to the particular project.

a. The sequence of erection activity, developed in coordination with the Controlling contractor, that includes the following:

- (1) Material deliveries;
- (2) Material staging and storage; and
- (3) Coordination with other trades and construction activities.

b. A description of the crane and derrick selection and placement procedures, including the following:

- (1) Site preparation;
- (2) Path for overhead loads; and
- (3) Identification of any lifts classified as critical lifts, requiring separate plans.

(4) If load-handling equipment (LHE) other than crane or derrick (e.g., All-Terrain Forklifts, Powered Industrial Trucks, etc.) is used, it must be used in accordance with the manufacturer's instructions. If LHE is used with rigging, see also Section 16.

c. A description of steel erection activities and procedures, including the following:

- (1) Stability considerations requiring temporary bracing and guying;
- (2) Erection bridging terminus point;
- (3) Anchor rod (anchor bolt) notifications regarding repair, replacement and modifications;
- (4) Columns and beams (including joists and purlins);
- (5) Connections;
- (6) Decking; and
- (7) Ornamental and miscellaneous iron.

d. A description of the fall protection procedures that will be used;

e. A description of the procedures that will be used to comply with this section including;

- (1) Activity hazard analysis in accordance with Section 1 of this manual;
- (2) A certification for each employee who has received training for performing steel erection operations as required by 29 CFR 1926.761;
- (3) A list of the QPs and CPs; and
- (4) A description of the procedures that will be utilized in the event of rescue or emergency response.

28.B.02. Steel erection activities include:

- a. Hoisting, laying out, placing, connecting, welding, burning, guying, bracing, bolting, plumbing, and rigging structural steel, steel joists and metal buildings;
- b. Installing metal decking, miscellaneous metals, ornamental iron, and similar materials; and
- c. Moving point-to-point while performing these activities.

28.B.03 Refer to 29 CFR 1926.750 (b)(2) for a list of activities that are covered (but may not normally be considered) and that occur during and are a part of steel erection activities.

28.B.04 Written notifications. Before authorizing the commencement of steel erection, the Controlling contractor shall ensure that the steel erector is provided with the following written notifications:

- a. The concrete in the footings, piers, and walls has attained, on the basis of an appropriate ASTM standard test method of field-cured samples, either 75% of the intended minimum compressive design strength or sufficient strength to support the loads imposed during steel erection.
- b. Any repairs, replacements, and modifications to the anchor bolts were conducted in accordance with contract specifications and/or project structural engineer of record.
- c. A steel erection contractor shall not erect steel unless it has received written notification that the concrete in the footings, piers and walls has attained, on the basis of an appropriate ASTM standard test method of field-cured samples, either 75% of the intended minimum compressive design strength or sufficient strength to support the loads imposed during steel erection.
- d. Both steel and concrete contractors will keep a copy of this written notification on-site.

28.B.05 Site layout. The Controlling contractor shall ensure that the following is provided and maintained:

- a. Adequate access roads into and through the site for the safe delivery and movement of derricks, cranes, trucks, other necessary equipment, and the material to be erected; and means and methods for pedestrian and vehicular control.

➤ *Exception: This requirement does not apply to roads outside of the construction site.*

b. An adequately compacted, properly graded, drained area readily accessible to the work with adequate space for the safe storage of materials and the safe operation of the erector's equipment.

c. Pre-planning of overhead hoisting operations. All hoisting operations in steel erection shall be pre-planned.

28.B.06 Load Handling Equipment (LHE) and rigging. All the applicable requirements of Sections 15 and 16 apply to this Section.

28.B.07 Inspection of LHE (cranes, hoists, etc). A CP shall visually inspect LHE being used in steel erection activities prior to each shift as per Section 16.D.

28.B.08 LHE. If any deficiency is identified, an immediate determination shall be made by the CP as to whether the deficiency constitutes a hazard.

a. If the deficiency is determined to constitute a hazard, the LHE shall be removed from service until the deficiency has been corrected.

b. The operator shall be responsible for those operations under the operator's direct control. Whenever there is any doubt as to safety, the operator shall have the authority to stop and refuse to handle loads until safety has been assured.

28.B.09 A Qualified Rigger shall inspect the rigging prior to each shift.

28.B.10 The headache ball, hook, or load shall not be used to transport personnel.

28.B.11 LHE may be used to hoist employees on a personnel platform when all applicable provisions of Section 16.T have been met.

28.B.12 Safety latches on hooks shall not be deactivated or made inoperable.

28.B.13 Structural steel assembly.

a. Structural stability shall be maintained at all times during the erection process.

b. The following additional requirements shall apply for multi-story structures:

(1) The permanent floors shall be installed as the erection of structural members progresses, and there shall be not more than eight stories between the erection floor

and the upper-most permanent floor, except where the structural integrity is maintained as a result of the design.

(2) At no time shall there be more than four floors or 48 ft (14.6 m), whichever is less, of unfinished bolting or welding above the foundation or uppermost permanently secured floor, except where the structural integrity is maintained as a result of the design.

28.B.14 Walking/working surfaces.

a. Shear connectors and other similar devices.

(1) Tripping hazards. Shear connectors (such as headed steel studs, steel bars, or steel lugs), reinforcing bars, deformed anchors or threaded studs shall not be attached to the top flanges of beams, joists, or beam attachments so that they project vertically from or horizontally across the top flange of the member until after the metal decking, or other walking/working surface, has been installed.

(2) Installation of shear connectors on composite floors, roofs, and bridge decks. When shear connectors are used in construction of composite floors, roofs, and bridge decks, employees shall lay out and install the shear connectors after the metal decking has been installed, using the metal decking as a working platform.

b. Bracing.

(1) When deemed necessary by a CP, temporary erection bracing equipment shall be installed in conjunction with the steel erection process to ensure the stability of the structure.

(2) When used, bracing equipment shall be in place and properly installed before the structure is loaded with construction material such as loads of joists, bundles of decking, or bundles of bridging.

(3) Bracing equipment shall be removed only with the approval of a CP.

c. Metal decking - Hoisting, landing, and placing of metal decking bundles.

(1) Bundle packaging and strapping shall not be used for hoisting unless specifically designed for that purpose.

(2) If loose items such as dunnage, flashing, or other materials are placed on the top of metal decking bundles to be hoisted, such items shall be secured to the bundles.

(3) Bundles of metal decking on joists shall be landed in accordance with Section 28.B.26.

(4) Metal decking bundles shall be landed on framing members so that enough support is provided to allow the bundles to be unbanded without dislodging the bundles from the supports.

(5) At the end of the shift or when environmental or jobsite conditions require, metal decking shall be secured against displacement.

(6) Roof and floor holes and openings. Metal decking at roof and floor holes and openings shall be installed as follows:

(i) Framed metal deck openings shall have structural members turned down to allow continuous deck installation except where not allowed by structural design constraints or constructability.

(ii) Roof and floor holes and openings shall be decked over or protected in accordance with Section 24.

(iii) Metal decking holes and openings shall not be cut until immediately prior to being permanently filled with the equipment or structure needed or intended to fulfill its specific use and that meets the strength requirements of Section 24, or shall be immediately covered or guarded.

28.B.15 Installation of metal decking.

a. Metal decking shall be laid tightly and secured upon placement to prevent accidental movement or displacement. A maximum of 3,000 ft² (278.7 m²) may be laid before securing.

b. During initial placement metal-decking panels shall be placed to ensure full support by structural members.

28.B.16 Derrick floors.

a. A derrick floor shall be fully decked and/or planked and the steel member connections completed to support the intended floor loading.

b. Temporary loads placed on a derrick floor shall be distributed over the underlying support members so as to prevent local overloading of the deck material.

28.B.17 Column anchorage.

a. General requirements for erection stability.

(1) All columns shall be anchored by a minimum of four anchor rods or anchor bolts.

(2) Each column anchor rod or anchor bolt assembly, including the column-to-base plate weld and the column foundation, shall be designed to resist a minimum eccentric gravity load of 300 lbs (136.2 kg) located 18 in (45.7 cm) from the extreme outer face of the column in each direction at the top of the column shaft.

(3) Columns shall be set on level finished floors, pre-grouted leveling plates, leveling nuts, or shim packs. If shim packs are used, they must be used at the direction of a qualified person.

(4) All columns shall be evaluated by a CP to determine whether guying or bracing is needed; if guying or bracing is needed, it shall be installed.

b. Repair, replacement or field modification of anchor rods or anchor bolts.

(1) Anchor rods or anchor bolts shall not be repaired, replaced, or field-modified without the approval of the project structural engineer of record.

(2) Prior to the erection of a column, the Controlling Contractor shall provide written notification to the steel erector if there has been any repair, replacement, or modification of the anchor rods or anchor bolts of that column.

28.B.18 Beams and columns.

a. During the final placing of solid web structural members, the load shall not be released from the hoisting line until the members are secured with at least two bolts per connection (of the same size and strength as shown in the erection drawings) drawn up wrench-tight or the equivalent as specified by the project structural engineer of record, except as specified in Section 28.B.19.

b. A CP shall determine those pieces that require more than two bolts in each end before the piece is released from the crane. Column erection splices shall be completely bolted prior to adding more than two floors.

28.B.19 Diagonal bracing. Solid web structural members used as diagonal bracing shall be secured by at least one bolt per connection drawn up wrench-tight or the equivalent as specified by the project structural engineer of record.

28.B.20 Double connections.

a. Double connections at columns and/or at beam webs over a column. When two structural members on opposite sides of a column web, or a beam web over a column, are connected sharing common connection holes, at least one bolt with its wrench-tight nut shall remain connected to the first member unless a shop-attached or field-attached seat or equivalent connection device is supplied with the member to secure the first member and prevent the column from being displaced. > See Figures 28-1 and 28-2.

b. If a seat or equivalent device is used, the seat (or device) shall be designed to support the load during the double connection process. It shall be adequately bolted or welded to both a supporting member and the first member before the nuts on the shared bolts are removed to make the double connection.

28.B.21 Column splices. Each column splice shall be designed to resist a minimum eccentric gravity load of 300 lbs (136.2 kg) located 18 in (45.7 cm) from the extreme outer face of the column in each direction at the top of the column shaft.

28.B.22 Perimeter columns. Perimeter columns shall not be erected unless:

a. The perimeter columns extend a minimum of 48 in (121.9 cm) above the finished floor to permit installation of perimeter safety cables prior to erection of the next tier, except where constructability does not allow.

b. The perimeter columns have holes or other devices in or attached to perimeter columns at 42-45 in (106.6-114.3 cm) above the finished floor and at the midpoint between the finished floor and the top cable to permit installation of perimeter safety cables except where constructability does not allow.

28.B.23 Open web steel joists.

a. Except as provided in paragraph (b)(2) below, where steel joists are used and columns are not framed in at least two directions with solid web structural steel members, a steel joist shall be field-bolted at the column to provide lateral stability to the column during erection. For the installation of this joist:

(1) A vertical stabilizer plate shall be provided on each column for steel joists. The plate shall be a minimum of 6-in x 6-in (15.2-cm x 15.2-cm) and shall extend at least 3 in (7.6 cm) below the bottom chord of the joist with a 13/16-in (2.1-cm) hole to provide an attachment point for guying or plumbing cables.

FIGURE 28-1

Controlling Risk for Double Connections in Steel Erection (Side View)

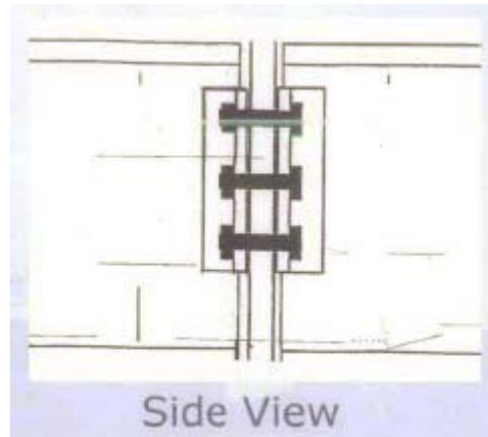
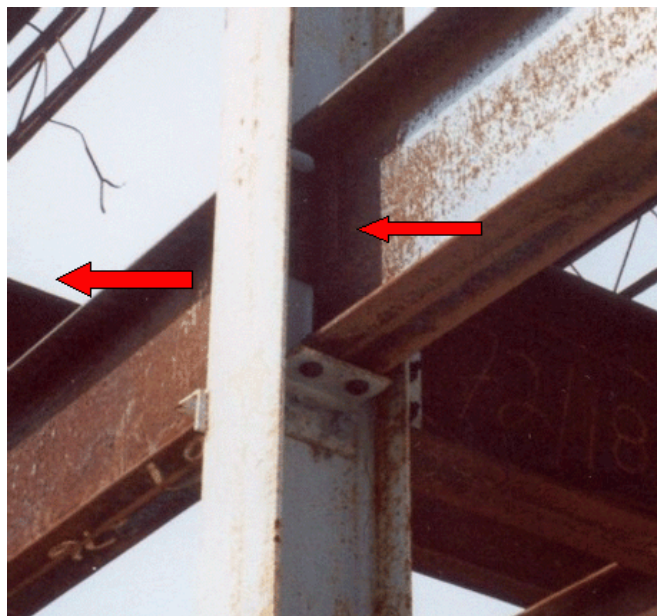

FIGURE 28-2

Double Connection with Seat to Support First Section while Second Section is Being Installed



(2) The bottom chords of steel joists at columns shall be stabilized to prevent rotation during erection.

(3) Hoisting cables shall not be released until the seat at each end of the steel joist is field-bolted, and each end of the bottom chord is restrained by the column stabilizer plate.

b. Where constructability does not allow a steel joist to be installed at the column:

(1) An alternate means of stabilizing joists shall be installed on both sides near the column and shall:

- (i) Provide stability equivalent to Section 28.B.23.a (1) above,
- (ii) Be designed by a QP,
- (iii) Be shop installed, and
- (iv) Be included in the erection drawings.

(2) Hoisting cables shall not be released until the seat at each end of the steel joist is field-bolted and the joist is stabilized.

c. Where steel joists at or near columns that span 60 ft (18.3 m) or less, the joist shall be designed and erected by either:

- (1) installing bridging or otherwise stabilizing the joist prior to releasing the hoisting cable or,
- (2) releasing the cable without having a worker on the joist.

d. Where steel joists at or near columns span more than 60 ft (18.3 m), the joists shall be set in tandem with all bridging installed unless an alternative method of erection, which provides equivalent stability to the steel joist, is designed by a QP and is included in the site-specific Steel Erection Plan.

e. A steel joist or steel joist girder shall not be placed on any support structure unless such structure is stabilized.

f. When steel joist(s) are landed on a structure, they shall be secured to prevent unintentional displacement prior to installation.

g. No modification that affects the strength of a steel joist or steel joist girder shall be made without the approval of the project structural engineer of record.

h. Field-bolted joists.

(1) Except for steel joists that have been pre-assembled into panels, connections of individual steel joists to steel structures in bays of 40 ft (12.1 m) or more shall be fabricated to allow for field bolting during erection.

(2) These connections shall be field-bolted unless constructability does not allow.

i. Steel joists and steel joist girders shall not be used as anchorage points for a fall arrest system unless written approval to do so is obtained from a QP.

j. A bridging terminus point shall be established before bridging is installed.

28.B.24 Attachment of steel joists and steel joist girders.

a. Each end of "K" series steel joists shall be attached to the support structure with a minimum of two 1/8-in (0.3-cm) fillet welds that are 2 in (5 cm) long, or with two 1/2-in (1.2-cm) bolts, or the equivalent.

b. Each end of "LH" and "DLH" series steel joists and steel joist girders shall be attached to the support structure with a minimum of two 1/4-inch (0.6-cm) fillet welds 2 in (5 cm) long, or with two 3/4-in (1.9-cm) bolts, or the equivalent.

c. Except as provided in paragraph d below, each steel joist shall be attached to the support structure, at least at one end on both sides of the seat, immediately upon placement in the final erection position and before additional joists are placed.

d. Panels that have been pre-assembled from steel joists with bridging shall be attached to the structure at each corner before the hoisting cables are released.

28.B.25 Erection of steel joists.

a. Both sides of the seat of one end of each steel joist that requires bridging under Tables 28-1 and 28-2 shall be attached to the support structure before hoisting cables are released.

b. For joists over 60 ft (18.2 m), both ends of the joist shall be attached as specified in Section 28.B.24 and the provisions of Section 28.B.26 are met before the hoisting cables are released.

EM 385-1-1
XX Jul 14

c. On steel joists that do not require erection bridging under Tables 28-1 and 28-2, only one employee shall be allowed on the joist until all bridging is installed and anchored.

d. Employees shall not be allowed on steel joists where the span of the steel joist is equal to or greater than the span shown in Tables 28-1 and 28-2 in accordance with Section 28.B.26.

e. When permanent bridging terminus points cannot be used during erection, additional temporary bridging terminus points are required to provide stability.

28.B.26 Erection bridging.

a. Where the span of the steel joist is equal to or greater than the span shown in Tables 28-1 and 28-2, the following shall apply:

(1) A row of bolted diagonal erection bridging shall be installed near the mid-span of the steel joist,

(2) Hoisting cables shall not be released until this bolted diagonal erection bridging is installed and anchored, see Figure 28-3, and

(3) No more than one employee shall be allowed on these spans until all other bridging is installed and anchored.

b. Where the span of the steel joist is over 60 ft (18.2 m) through 100 ft (30.4 m), the following shall apply:

(1) All rows of bridging shall be bolted diagonal bridging,

(2) Two rows of bolted diagonal erection bridging shall be installed near the third points of the steel joist,

(3) Hoisting cables shall not be released until this bolted diagonal erection bridging is installed and anchored, and

(4) No more than two employees shall be allowed on these spans until all other bridging is installed and anchored.

c. Where the span of the steel joist is over 100 ft (30.4 m) through 144 ft (43.9 m), the following shall apply:

(1) All rows of bridging shall be bolted diagonal bridging,

(2) Hoisting cables shall not be released until all bridging is installed and anchored, and

(3) No more than two employees shall be allowed on these spans until all bridging is installed and anchored.

d. For steel members spanning over 144 ft (43.9 m), the erection methods used shall be in accordance with Sections 28.B.18 through 28.B.22.

e. Where any steel joist specified in paragraph b above or Section 28.B.26.a-c is a bottom chord-bearing joist, a row of bolted diagonal bridging shall be provided near the support(s). This bridging shall be installed and anchored before the hoisting cable(s) is released.

f. When bolted diagonal erection bridging is required by this section, the following shall apply:

(1) The bridging shall be indicated on the erection drawing;

(2) The erection drawing shall be the exclusive indicator of the proper placement of this bridging;

(3) Shop-installed bridging clips, or functional equivalents, shall be used where the bridging bolts to the steel joists, see Figures 28-4 and 28-5;

(4) When two pieces of bridging are attached to the steel joist by a common bolt, the nut that secures the first piece of bridging shall not be removed from the bolt for the attachment of the second; and

(5) Bridging attachments shall not protrude above the top chord of the steel joist.

28.B.26 Landing and placing loads.

a. During the construction period, the employer placing a load on steel joists shall ensure that the load is distributed so as not to exceed the carrying capacity of any steel joist.

b. Except for paragraph d below, no construction loads are allowed on the steel joists until all bridging is installed and anchored and all joist-bearing ends are attached.

c. The weight of a bundle of joist bridging shall not exceed a total of 1,000 lbs (454 kg). A bundle of joist bridging shall be placed on a minimum of three steel joists that are secured at one end. The edge of the bridging bundle shall be positioned within 1 ft (0.3 m) of the secured end.

d. No bundle of decking may be placed on steel joists until all bridging has been installed and anchored and all joist bearing ends attached, unless all of the following conditions are met:

(1) The employer has first determined from a QP and documented in a site-specific Steel Erection Plan that the structure or portion of the structure is capable of supporting the load,

(2) The bundle of decking is placed on a minimum of three steel joists,

(3) The joists supporting the bundle of decking are attached at both ends,

(4) At least one row of bridging is installed and anchored,

(5) The total weight of the bundle of decking does not exceed 4,000 lbs (1816 kg), and the edge of the construction load shall be placed within 1 ft (0.3 m) of the bearing surface of the joist end.

28.C Systems-Engineered Metal Buildings.

28.C.01 All of the requirements of the previous section apply to the erection of systems-engineered metal buildings except Sections 28.B.17 (column anchorage) and 28.B.23 (open web steel joists).

a. Each structural column shall be anchored by a minimum of four anchor rods or anchor bolts.

b. Rigid frames shall have 50% of their bolts or the number of bolts specified by the manufacturer (whichever is greater) installed and tightened on both sides of the web adjacent to each flange before the hoisting equipment is released.

c. Construction loads shall not be placed on any structural steel framework unless such framework is safely bolted, welded, or otherwise adequately secured.

d. In girt and eave strut-to-frame connections, when girts or eave struts share common connection holes, at least one bolt with its wrench-tight nut shall remain connected to the first member unless a manufacturer-supplied, field-attached seat or similar connection device is present to secure the first member so that the girt or eave strut is always secured against displacement.

e. Purlins and girts shall not be used as an anchorage point for a fall arrest system unless written approval is obtained from a QP for Fall Protection.

f. Purlins may only be used as a walking/working surface when installing safety systems after all permanent bridging has been installed and fall protection is provided.

g. Construction loads may be placed only within a zone that is within 8 ft (2.4 m) of the centerline of the primary support member.

h. Both ends of all steel joists or cold-formed joists shall be fully bolted and/or welded to the support structure before:

- (1) Releasing the hoisting cables,
- (2) Allowing an employee on the joists, or
- (3) Allowing any construction loads on the joists.

28.C.02 Falling object protection.

a. Securing loose items aloft. All materials, equipment, and tools, which are not in use while aloft, shall be secured against accidental displacement.

b. Protection from falling objects other than materials being hoisted shall be provided. The Controlling contractor shall bar other construction processes below steel erection unless overhead protection for the employees below is provided.

28.C.03 Controlled Decking Zones (CDZ) are not permitted.

TABLE 28-1

Erection Bridging for Short Span Joists

JOIST	SPAN	JOIST	SPAN
8K1	NM	22K6	36-0
10K1	NM	22K7	40-0
12K1	23-0	22K9	40-0
12K3	NM	22K10	NM
12K5	NM	22K11	NM
14K1	27-0	24K4	36-0
14K3	NM	24K5	38-0
14K4	NM	24K6	39-0
14K6	NM	24K7	43-0
16K2	29-0	24K8	43-0
16K3	30-0	24K9	44-0
16K4	32-0	24K10	NM
16K5	32-0	24K12	NM
16K6	NM	26K5	38-0
16K7	NM	26K6	39-0
16K9	NM	26K7	43-0
18K3	31-0	26K8	44-0
18K4	32-0	26K9	44-0
18K5	33-0	26K10	49-0
18K6	28-0	26K12	NM
18K7	NM	28K6	40-0
18K9	NM	28K7	43-0
18K10	NM	28K8	44-0
20K3	32-0	28K9	45-0
20K4	34-0	28K10	49-0
20K5	34-0	28K12	53-0
20K6	36-0	30K7	44-0
20K7	39-0	30K8	45-0
20K9	39-0	30K9	45-0
20K10	NM	30K10	50-0
22K4	34-0	30K11	52-0

TABLE 28-1 (Continued)

Erection Bridging for Short Span Joists

JOIST	SPAN	JOIST	SPAN
22K5	28-0	30K12	54-0
10KCS1	NM	22KCS2	36-0
10KCS2	NM	22KCS3	40-0
10KCS3	NM	22KCS4	NM
12KCS1	NM	22KCS5	NM
12KCS2	NM	24KCS2	39-0
12KCS3	NM	24KCS3	44-0
14KCS1	NM	24KCS4	NM
14KCS2	NM	24KCS5	NM
14KCS3	NM	26KCS2	39-0
16KCS2	NM	26KCS3	44-0
16KCS3	NM	26KCS4	NM
16KCS4	NM	26KCS5	NM
16KCS5	NM	28KCS2	40-0
18KCS2	28-0	28KCS3	45-0
18KCS3	NM	28KCS4	53-0
18KCS4	NM	28KCS5	53-0
18KCS5	NM	30KCS3	45-0
20KCS2	36-0	30KCS4	54-0
20KCS3	39-0	30KCS5	54-0
20KCS4	NM		
20KCS5	NM		

NM=diagonal bolted bridging not mandatory for joists under 40 ft (12.1 m).

TABLE 28-2

Erection Bridging for Long Span Joists

JOIST	SPAN	JOIST	SPAN
18LH02	33-0	28LH05	42-0
18LH03	NM	28LH06	46-0
18LH04	NM	28LH07	54-0
18LH05	NM	28LH08	54-0
18LH06	NM	28LH09	NM
18LH07	NM	28LH10	NM
18LH08	NM	28LH11	NM
18LH09	NM	28LH12	NM
20LH02	33-0	28LH13	NM
20LH03	38-0	32LH06	47-0 THROUGH 60-0
20LH04	NM	32LH07	47-0 THROUGH 60-0
20LH05	NM	32LH08	55-0 THROUGH 60-0
20LH06	NM	32LH09	NM THROUGH 60-0
20LH07	NM	32LH10	NM THROUGH 60-0
20LH08	NM	32LH11	NM THROUGH 60-0
20LH09	NM	32LH12	NM THROUGH 60-0
20LH10	NM	32LH13	NM THROUGH 60-0
24LH03	28-0	32LH14	NM THROUGH 60-0
24LH04	39-0	32LH15	NM THROUGH 60-0
24LH05	40-0	36LH07	47-0 THROUGH 60-0
24LH06	45-0	36LH08	47-0 THROUGH 60-0
24LH07	NM	36LH09	57-0 THROUGH 60-0
24LH08	NM	36LH10	NM THROUGH 60-0
24LH09	NM	36LH11	NM THROUGH 60-0
24LH10	NM	36LH12	NM THROUGH 60-0
24LH11	NM	36LH13	NM THROUGH 60-0
		36LH14	NM THROUGH 60-0
		36LH15	NM THROUGH 60-0

NM = diagonal bolted bridging not mandatory for joists under 40 feet (12.1 m).

FIGURE 28-3

Illustrations of OSHA Bridging Terminus Points

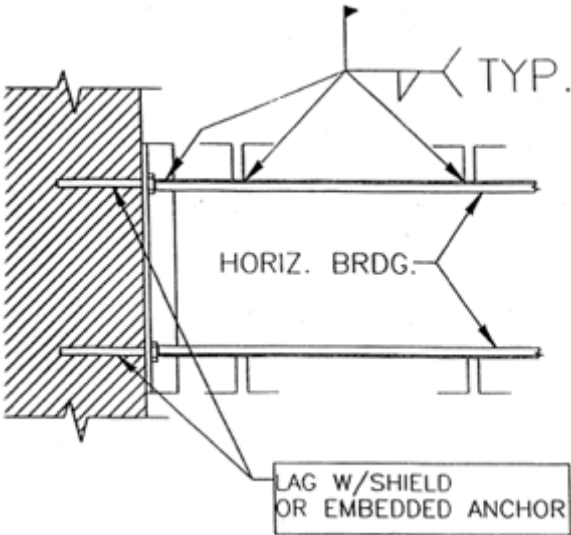

Horizontal Bridging
Terminus at Wall

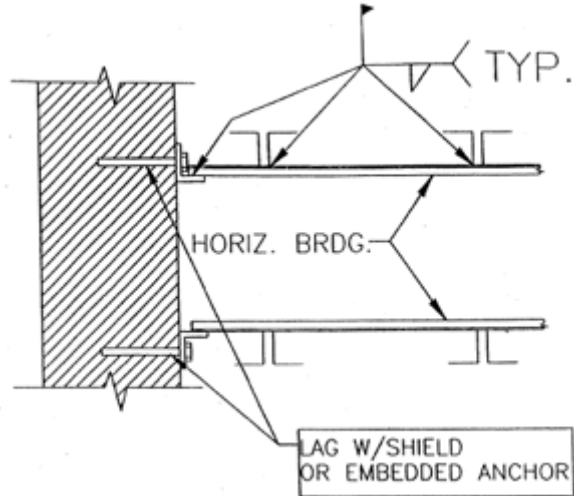

Horizontal Bridging
Terminus at Wall

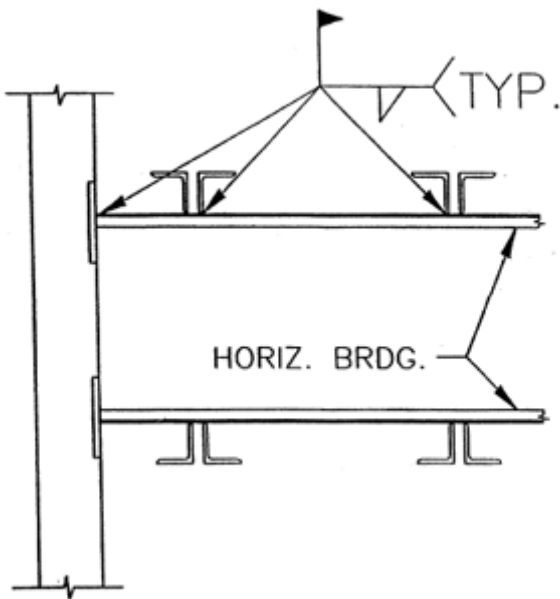

Horizontal Bridging
Terminus at Panel

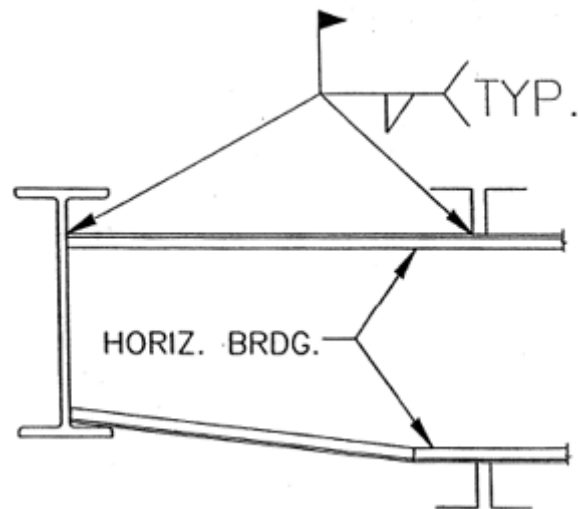

Horizontal Bridging
Terminus at Structural Shape Wall

FIGURE 28-3 (Continued)

Illustrations of OSHA Bridging Terminus Points

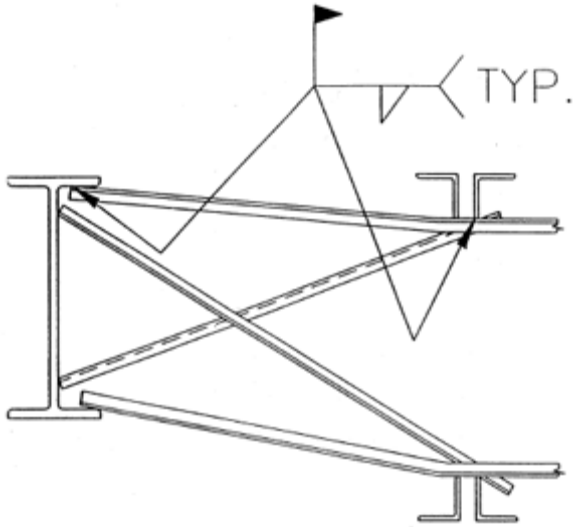

Horizontal Bridging
Terminus at Structural
Shape with Optional "X-Bridging"

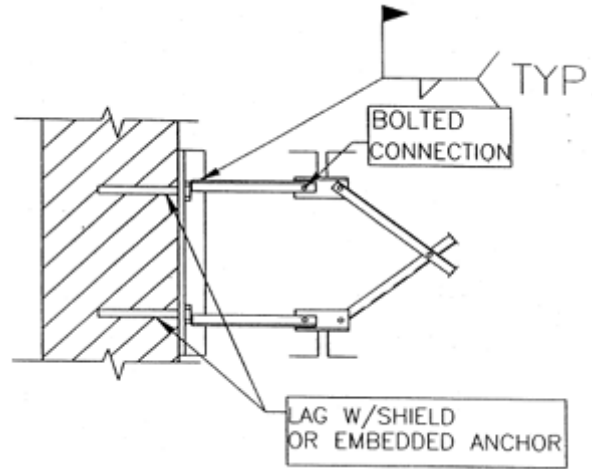

Bolted Diagonal Bridging
Terminus at Wall

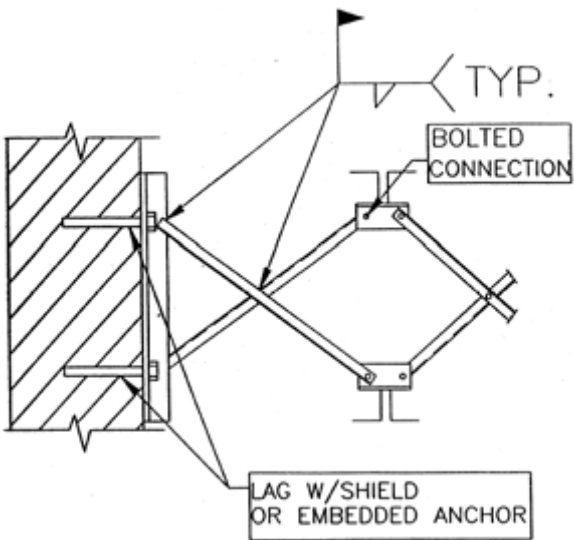

Bolted Diagonal Bridging
Terminus at Wall

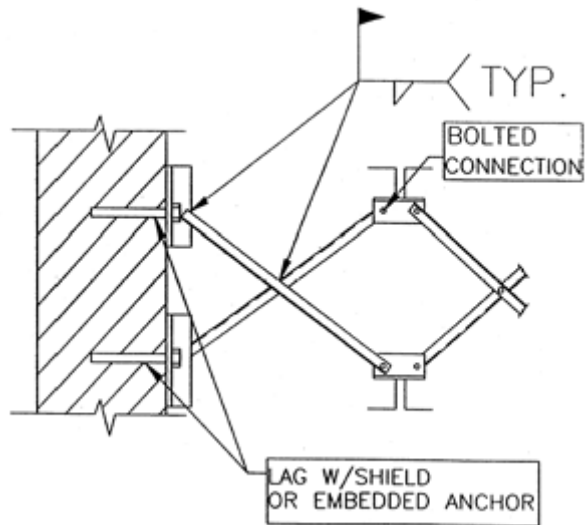

Bolted Diagonal Bridging
Terminus at Wall

FIGURE 28-3 (Continued)

Illustrations of OSHA Bridging Terminus Points

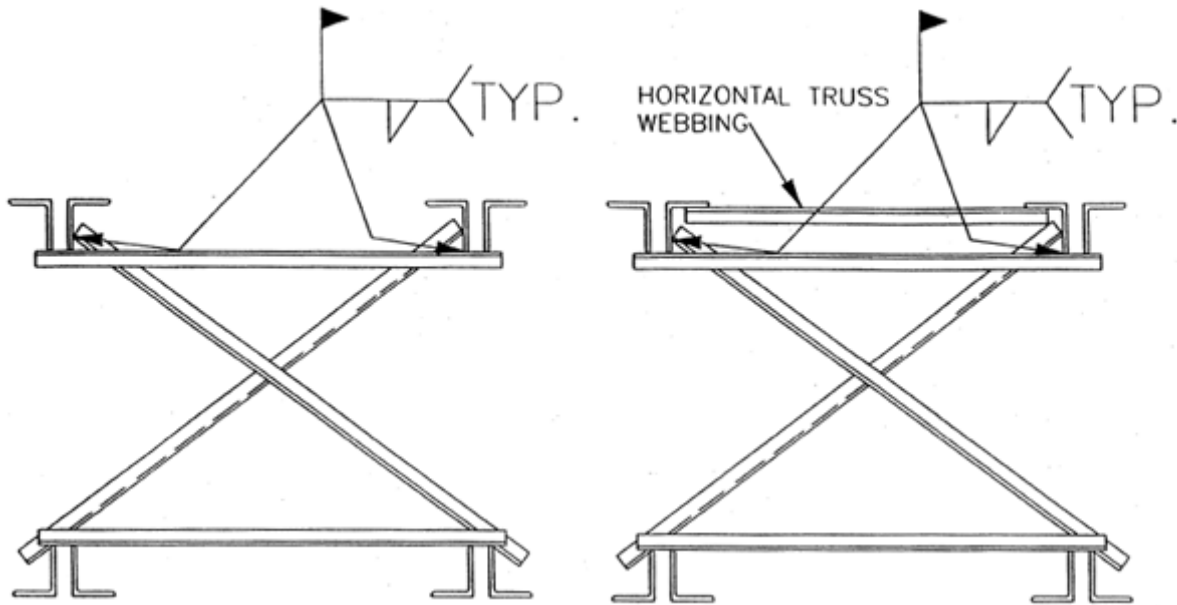

Joists Pair Bridging
Terminus Point

Joists Pair Bridging
Terminus Point with Horizontal Truss

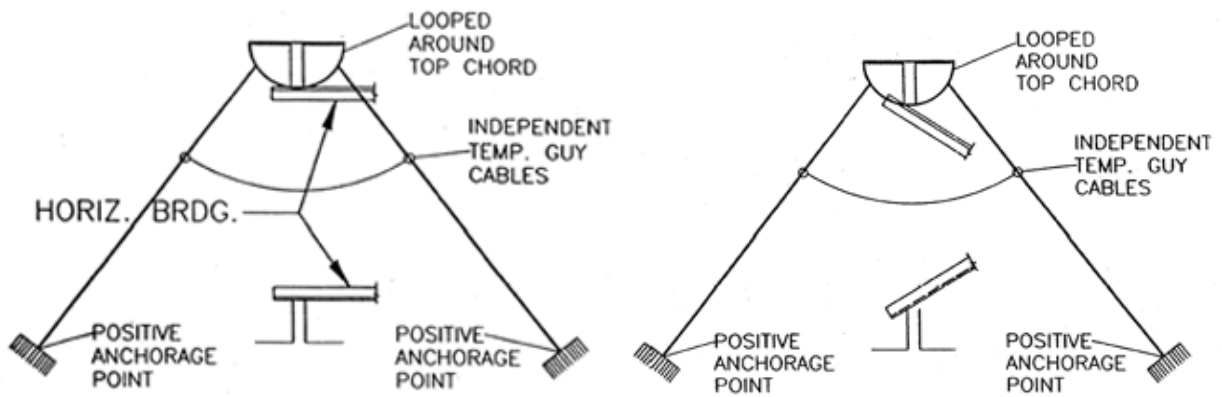

Horizontal Bridging
Terminus Point
Secured By Temporary Guy Cables

Diagonal Bridging
Terminus Point
Secured by Temporary Guy Cables

FIGURE 28-4

Clip End Connection

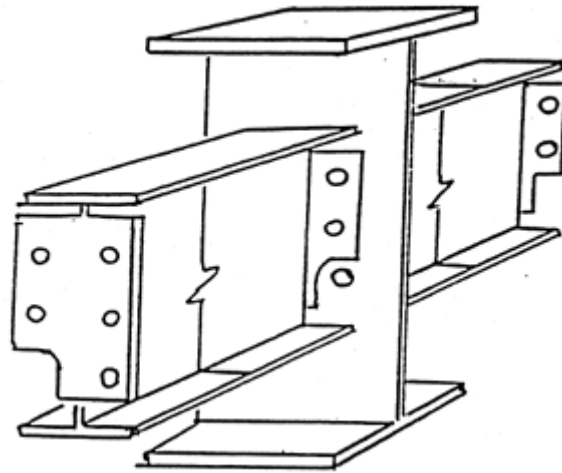
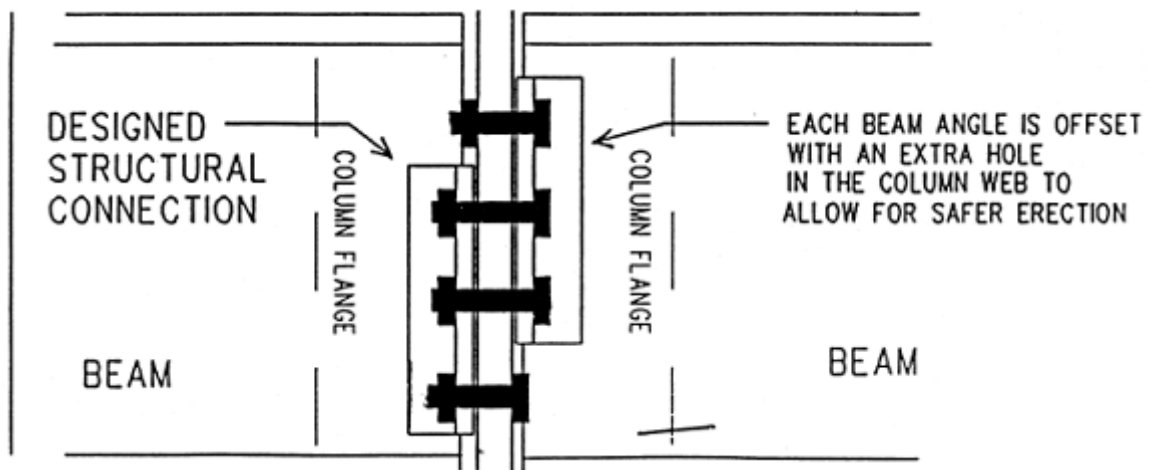

Figure 28-5

Staggered (High/Low Connection)



Guidelines for Complying with OSHA Steel Erection Standard,
Paragraph §1926.757(a)(10) and §1926.757(c)(5).