



**US Army Corps
of Engineers®**
Los Angeles District

Los Angeles River Ecosystem Restoration Feasibility Study

**DRAFT – APPENDIX A
DESIGN**

August 2013

**LOS ANGELES RIVER ECOSYSTEM RESTORATION FEASIBILITY STUDY
DESIGN APPENDIX**

TABLE OF CONTENTS

1.	INTRODUCTION.....	1
2.	REACH ALIGNMENTS AND GEOMETRIES	2
2.1	Sub-Reaches	2
2.1.1	Pollywog Park/Headworks to the Downstream Edge of the Concrete Bed at the Midpoint of Bette Davis Park (BDP)	2
2.1.2	Midpoint BDP to Upstream Edge of Ferraro Fields	3
2.1.3	Ferraro Fields to Brazil Street	3
2.1.4	Brazil Street to Los Feliz Boulevard.....	3
2.1.5	Los Feliz Boulevard to Glendale Freeway	3
2.1.6	Glendale Freeway to I-5.....	4
2.1.7	I-5 to Main.....	4
2.1.8	Main to 1st Street	4
3.	ECOSYSTEM RESTORATION MEASURES AND PRELIMINARY ALTERNATIVES	5
3.1	Ecosystem Restoration Measures	5
3.1.1	Adjacent or Off-Channel Modifications	5
3.1.2	Attenuation	10
3.1.3	Wildlife Access	11
3.1.4	Planting	11
3.1.5	Remove Concrete.....	12
3.1.6	Reshape Channel.....	13
3.2	Preliminary Ecosystem Restoration Alternatives.....	13
4.	PRELIMINARY FEASIBILITY DESIGNS	16
4.1	Assumptions and Limitations	16
4.2	Cross-Sections	17
4.2.1	Cross-Section 1, Sub-Reach 1 - Pollywog Park/Headworks to Midpoint of Betty Davis Park.....	19
4.2.2	Burbank-Western Channel Cross-Section, Sub-Reach 1 - Confluence at the Los Angeles River	22
4.2.3	Cross-Section 2, Sub-Reach 2 - Midpoint of Betty Davis Park to Upstream End of Ferraro Fields.....	24
4.2.4	Cross-Section 3, Sub-Reach 3 - Ferraro Fields to Brazil Street	27
4.2.5	Verdugo Wash Cross-Section 1, Sub-Reach 3 - Upstream of the Los Angeles River Confluence	30
4.2.6	Verdugo Wash Cross-Section 2, Sub-Reach 3 - Upstream of Los Angeles River Confluence	32
4.2.7	Verdugo Wash Cross-Section 3, Sub-Reach 3 - Los Angeles River Confluence	35

4.2.8	Cross-Section 4, Sub-Reach 4 - Brazil to Los Feliz Boulevard.....	38
4.2.9	Cross-Section 5, Sub-Reach 5 - Los Feliz Boulevard to Glendale Freeway.....	41
4.2.10	Cross-Section 6a, Sub-Reach 6 - Glendale Freeway to Interstate 5	44
4.2.11	Cross-Section 6b, Sub-Reach 6 - Glendale Freeway to Interstate 5	46
4.2.12	Cross-Section 6c, Sub-Reach 6 - Glendale Freeway to Interstate 5.....	48
4.2.13	Cross-Section 7, Sub-Reach 7 - Interstate 5 to Main	50
4.2.14	Arroyo Seco Cross-Section, Sub-Reach 7 – Arroyo Seco Confluence	52
4.2.15	Cornfields Cross-Section, Sub-Reach 7, Cornfields Hydrologic Connection	54
4.2.16	Cross-Section 8a, Sub-Reach 8 - Main to First	56
4.2.17	Cross-Section 8b, Sub-Reach 8 - Main to First.....	59
5.	UTILITIES.....	62
6.	FINAL ARRAY OF ALTERNATIVES	63
6.1	Maps and Revised Cross-Sections	63
6.2	Alternative Reach Descriptions	65
6.2.1	Alternative 10 ARBOR Riparian Transitions (ART)	65
6.2.2	Alternative 13 ARBOR Corridor Extension (ACE)	66
6.2.3	Alternative 16 ARBOR Narrows to Downtown (AND).....	67
6.2.4	Alternative 20 ARBOR Riparian Integration via Varied Ecological Reintroduction (RIVER)	69

LIST OF TABLES

Table 3.1	Wetland Plant Palette.....	8
Table 3.2	Riparian and Buffer/Transitional Plant Palette.....	9
Table 3.3	Preliminary Array of 19 Alternatives	14
Table 6.1	Final Array of Alternatives Summarized	64

LIST OF FIGURES

Figure 3.1	Daylight Streams	6
Figure 3.2	Storm Gate Vault High Flow Bypass.....	7
Figure 4.1	Preliminary Design Cross-Section Locations by Sub-reach.....	18
Figure 4.2	Cross-Section 1, Pollywog Park/Headworks to Midpoint of Betty Davis Park	21
Figure 4.3	Burbank-Western Channel Cross-Section.....	23
Figure 4.4	Cross-Section 2, Midpoint Bette Davis Park to Upstream of Ferraro Fields.....	26
Figure 4.5	Cross-Section 3, Ferraro Fields to Brazil Street	29
Figure 4.6	Verdugo Wash Cross-Section 1, Upstream of Los Angeles River Confluence	31
Figure 4.7	Verdugo Wash Cross-Section 2, Upstream of Los Angeles River Confluence	33
Figure 4.8	Verdugo Was Cross-Section 2 (cont'd), Upstream of Los Angeles River Confluence	34
Figure 4.9	Verdugo Wash Cross-Section 3, Upstream of Los Angeles River Confluence	36
Figure 4.10	Verdugo Wash Cross-Section 3 (cont'd), Upstream of Los Angeles River Confluence	37
Figure 4.11	Cross-Section 4, Brazil to Los Feliz	40
Figure 4.12	Cross-Section 5, Los Feliz Boulevard to Glendale Freeway	43
Figure 4.13	Cross-Section 6a, Glendale Freeway to Interstate 5	45
Figure 4.14	Cross-Section 6b, Glendale Freeway to Interstate 5	47
Figure 4.15	Cross-Section 6c, Glendale Freeway to Interstate 5.....	49
Figure 4.16	Cross-Section 7, Interstate 6 to Main Street	51
Figure 4.17	Arroyo Seco Cross-Section	53
Figure 4.18	Cornfields Cross-Section	55
Figure 4.19	Cross-Section 8a, Main to First Street	58
Figure 4.20	Cross-Section 8b, Main to First Street	61

ATTACHMENTS

- Attachment 1 Alternatives and Measures Matrix
- Attachment 2 Utilities
- Attachment 3 Final Array Maps
- Attachment 4 Revised Cross-Sections

1. INTRODUCTION

The Los Angeles River Ecosystem Restoration Feasibility Study is evaluating ecosystem restoration opportunities on an 11.5-mile long reach of the Los Angeles River (River) located in southern California. This reach, named the Los Angeles River ARBOR (Area with Restoration Benefits and Opportunities for Revitalization) extends from the Headworks area¹ downstream to First Street in downtown Los Angeles. The ARBOR reach includes the Glendale Narrows—one of the few sections of the study area that does not have a hardened river bed—and contains several distinctive sites and connections including the Headworks, Pollywog Park, Bette Davis Park, the Burbank-Western Channel and Glendale River Walk, Griffith Park, Ferraro Fields, Verdugo Wash, Atwater Village, Taylor Yard and the Rio de Los Angeles State Park, the “Cornfields” (Los Angeles State Historic Park), Arroyo Seco, Elysian Park, “Piggyback Yard” (also known as the “Los Angeles Transportation Center” as well as “Mission Yard”), and downtown Los Angeles.

This appendix documents the preliminary array of conceptual alternatives based on plan formulation efforts through 2013 and includes: reach alignments and geometries (Section 2), a summary of ecosystem restoration measures and alternatives (Section 3), review of preliminary design features (Section 4), utilities potentially affecting future implementation of the project features (Section 5), and the final array of alternative plans (Section 6).

¹ The “Headworks” is a site owned by the LA Department of Water and Power that was formerly used for groundwater infiltration using Los Angeles River water. The facility includes water diversion appurtenances, including a rubber dam that is no longer operated for diversion.

2. REACH ALIGNMENTS AND GEOMETRIES

The 11.5-mile study area ARBOR reach has been divided into eight distinct reaches, or sub-reaches. This section reviews the alignment and geometry for each of the eight sub-reaches within the project bounds. Alignment describes the length and location in relation to known landmarks/roads, and geometry describes the channel shape/geomorphology of each sub-reach. The eight sub-reaches are outlined on Figure 4.1, “Preliminary Design Cross-Section Locations by Sub-reach.”

1. Pollywog Park/Headworks to the downstream edge of the concrete bed at the midpoint of Bette Davis Park (BDP)
2. Midpoint BDP to the upstream edge of Ferraro Fields
3. Ferraro Fields to Brazil Street
4. Brazil Street to Los Feliz Boulevard
5. Los Feliz Boulevard to the Glendale Freeway
6. Glendale Freeway to Interstate 5
7. Interstate 5 to Main Street
8. Main Street to 1st Street

2.1 Sub-Reaches

2.1.1 Pollywog Park/Headworks to the Downstream Edge of the Concrete Bed at the Midpoint of Bette Davis Park (BDP)

This sub-reach is approximately 1.5 miles in length and is located at the upstream boundary of the ARBOR reach. This reach connects the Headworks Ecosystem Restoration study area² with the area adjacent to Disney Studios in Burbank. Channel geometry in this reach is a rectangular reinforced concrete channel with dimensions typically 18 feet high and 130 feet wide. The Burbank-Western Channel enters the River just downstream of the Los Angeles Equestrian Center, at an approximate 45 degree angle. The geometry of the Burbank-Western Channel near the confluence is rectangular reinforced concrete with dimensions of 60 feet wide by 18 feet high.

² The Headworks Ecosystem Restoration Study is a separate, ongoing study being conducted in partnership with the Corps and the City of Los Angeles. It is authorized through utilization of the Los Angeles County Drainage Area (LACDA) Review flood control study, Senate Resolution approved 25 June 1969, as referenced in the Los Angeles River Watercourse Improvement, California, Reconnaissance Study, January 1993.

2.1.2 Midpoint BDP to Upstream Edge of Ferraro Fields

This sub-reach is approximately $\frac{3}{4}$ miles in length and extends from the midpoint of Bette Davis Park to the upstream location of Ferraro Fields just downstream the bridge crossing for Interstate 5. The channel geometry in this reach is a rectangular reinforced concrete channel with dimensions typically 18 feet high and 175 feet wide and is trapezoidal with a cobble bed and Derrick stone banks. The banks are toed-down with sheet pile and quarry run stone.

2.1.3 Ferraro Fields to Brazil Street

This sub-reach is approximately 1 mile in length and extends from the upstream edge of Ferraro Soccer Fields downstream to Brazil Street. The channel geometry is concrete rectangular reinforced channel 18 to 23 feet high and 180 to 380 feet wide. The Verdugo Wash confluences with the River on the left bank; the geometry of the confluence is a rectangular reinforced concrete channel. The Verdugo Wash channel bed contains deposits of sediment stabilized by vegetative growth, which spans 1,000 feet upstream of San Fernando Road.

2.1.4 Brazil Street to Los Feliz Boulevard

This sub-reach is approximately 1.75 miles in length and flows southerly from Brazil Street to the Los Feliz Boulevard Bridge. The channel geometry transitions from a rectangular reinforced concrete channel upstream of Brazil Street to an 18-foot high and 130- to 160-foot-wide trapezoidal channel with a cobble bed and grouted Derrick stone banks. The banks are toed-down with sheet pile and quarry run stone. The channel transitions back to a rectangular reinforced concrete channel at the downstream extent of the Los Feliz Boulevard Bridge. This section of the River has experienced sediment deposition which has subsequently formed bars and islands due to stabilization provided by tree/shrub root and vegetative cover establishment.

2.1.5 Los Feliz Boulevard to Glendale Freeway

This sub-reach is approximately 1.55 miles in length starting at the Los Feliz Boulevard Bridge and ending at the Glendale Freeway. A total of five bridges cross the channel within this sub-reach, as follows (in upstream to downstream order): Los Feliz Boulevard Bridge, Sunnynook pedestrian bridge, Hyperion Avenue Bridge, Fletcher Drive Bridge, and the Glendale Freeway (Hwy 2) Bridge. In general, the geometry of the channel between each bridge is trapezoidal and 18 feet high with a 130- to 160-foot-wide cobble bed. The channel banks are grouted riprap from Los Feliz Boulevard to Fletcher Drive, and transition to reinforced concrete from Fletcher Drive to the Glendale Freeway. The banks are toed-down with sheet pile quarry run stone. At each bridge crossing, the channel transitions to a downwardly-sloped concrete apron to create more advantageous flow conditions and to provide erosion protection. This section of the River has experienced sediment deposition which has subsequently formed bars and islands due to stabilization provided by tree/shrub root and vegetative cover establishment.

2.1.6 Glendale Freeway to I-5

This sub-reach is approximately 2.34 miles in length and extends from the Glendale Freeway Bridge to upstream of the crossing of the Interstate 5 Freeway. The geometry of the channel in between each bridge is trapezoidal with a cobble soft bottom and Derrick stone banks, and is 30 feet high and 190 to 215 feet wide. The banks are toed-down with sheet pile quarry run stone. This section of the river has experienced sediment deposition which has subsequently formed bars and islands due to stabilization provided by tree/shrub root and vegetative cover establishment. At each bridge crossing, the channel transitions to downwardly-sloped concrete apron to create more advantageous flow conditions and to provide erosion protection. The downstream geometry of the reach as it approaches the Interstate 5 Freeway transitions to a 170-foot-wide rectangular reinforced concrete channel. A 20-foot-wide low-flow channel begins within this transition and continues downstream.

2.1.7 I-5 to Main

This sub-reach is approximately one mile in length and begins at the Interstate 5 Bridge and ends downstream at the Main Street Bridge. The channel geometry is rectangular reinforced concrete channel that is 30 feet high and 150 to 190 feet wide with a 20-foot-wide low-flow channel in the bed. The Arroyo Seco confluences with the River at an approximate 60 degree angle on the left bank downstream of Highway 110. The geometry of the Arroyo Seco at the confluence is rectangular reinforced concrete channel 16 feet high and 66 feet wide, which transitions to trapezoidal reinforced concrete channel upstream. From upstream to downstream order, North Figueroa Street, Arroyo Seco Parkway, railway line, North Broadway, and North Spring Street all cross the channel within this reach.

2.1.8 Main to 1st Street

This sub-reach is approximately one mile in length and extends from the Main Street Bridge downstream to the First Street Bridge. The channel geometry is a trapezoidal reinforced concrete channel, 30 feet high and 170 to 200 feet wide. The bed has a low-flow channel throughout the reach.

3. ECOSYSTEM RESTORATION MEASURES AND PRELIMINARY ALTERNATIVES

Ecosystem restoration measures were developed to meet the study objectives. The development and evaluation of measures and alternatives is described in the main report and is not repeated herein. A measure is “a feature or activity that can be implemented at a specific geographic site to address one or more planning objectives.”³ Alternatives are defined in the main report to be “a set of one or more management measures functioning together to address one or more planning objectives.” The measures described below were first developed in a planning charette and further expanded and defined by the project team.

A matrix of alternatives and associated measures is provided as Attachment 1 to this document and is repeated in the Cost Appendix. This matrix includes these 19 preliminary alternatives across the top and the eight sub-reaches down the left. Measures and sub-measures that make up each of the alternatives, by reach, are shown within the matrix itself. Correlation of measures and the alternatives are designated with an “X.” The measures listed on the matrix should be referred to in conjunction with Sections 3.1 and 3.2 below.

3.1 Ecosystem Restoration Measures

The ecosystem restoration measures identified consist of one or more actions or features in a particular location that are intended to solve specific problems or help achieve particular planning objectives. Measures are broken-out into six major categories as discussed in the six sub-headings immediately below. Under each of the six major categories are associated sub-measures; potential design components are described under each measure.

3.1.1 Adjacent or Off-Channel Modifications

Adjacent and off-channel modifications include restoration measures both immediately adjacent to and separated from the main river channel. Potential sub-measures include the following. *Note that the numbering is not sequential* because screening of the sub-measures has occurred, as explained in Chapter 3, “Formulation of Alternative Plans,” of Volume 1 of the Integrated Feasibility Report.

(2) Restore riparian and marsh habitat by daylighting streams: Storm drains leading into the River would be modified with a transition structure that would divert low flows into a daylighted natural stream or wetland area where possible, especially where the rights-of-way are sufficient to do so. The wetlands or ponds created within the drainage area would provide habitat and water quality treatment. Existing storm drains would remain in place after modification to convey peak storm flows. Design of the outlet and adjacent wetland is site-specific and depends on sizing, discharge, and available right-of-way.

³ USACE, 1996. IWR Report 96-R-21, Planning Manual.

Figure 3.1, displays the conceptual design of this sub-measure:

1. A low-flow diversion/high-flow bypass
2. A pipe diverting low flows from the splitter box to the wetland
3. A benched wetland area built into the wall or overbank area of the channel providing treatment capacity and added habitat value to the river corridor
4. A drainage pipe to be constructed from the base of the wetland to the channel wall
5. Existing storm drain line feeding into the low-flow splitter box up-gradient of the existing channel wall storm drain outlet

The low-flow diversion/high-flow bypass would allow the existing storm drain's nuisance flow and first flush pollutants to be diverted from the storm drain line to the wetland area for treatment and infiltration, and then returned back into the River. Contech's proprietary "StormGate Vault" or other approved, equivalent vault is recommended for the low-flow diversion/high-flow bypass as shown in Figure 3.2. A pipe with an approximate measurement of 24 inches would be used to divert low flows from the splitter box down-gradient to the wetland area. The wetland bench would be lined with a rock/soil filter for infiltration and then drained back through the sideslope of the channel. On top of the rock filter substrate would be additional topsoil and wetland vegetation planted according to the project biologist's recommendations, consistent with the plant palette seen in Table 3.1.

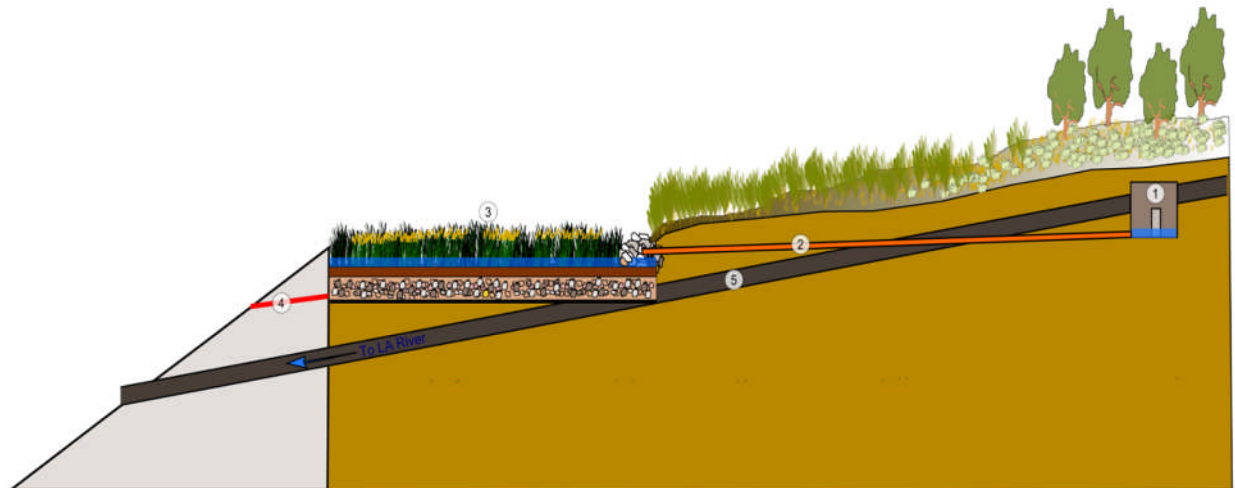
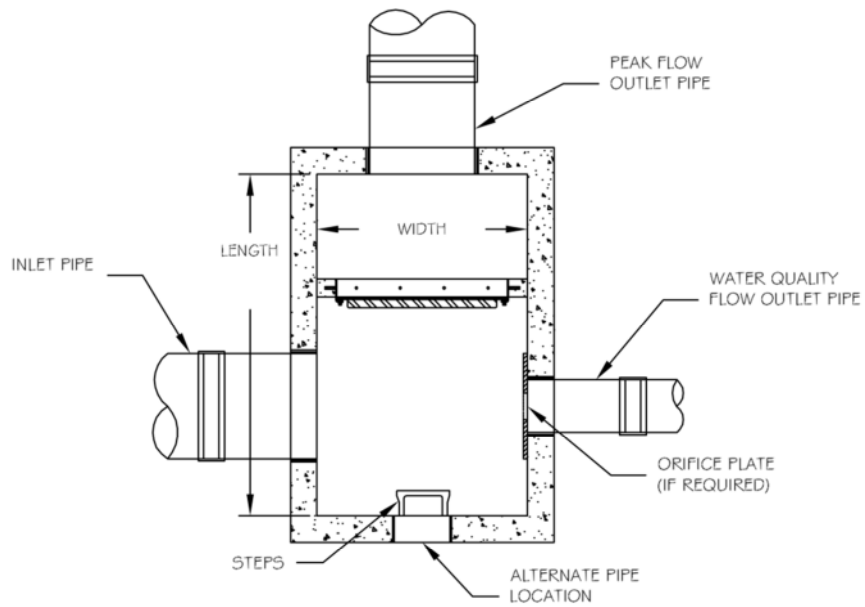
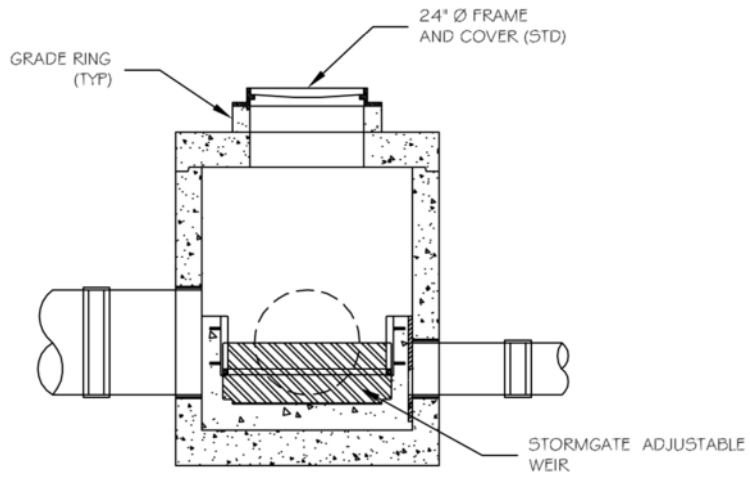

Figure 3.1 Daylight Streams



STORMGATE VAULT - PLAN VIEW



STORMGATE VAULT - SECTION VIEW

Figure 3.2 Storm Gate Vault High Flow Bypass

(3) Create geomorphology and plant for freshwater marsh in adjacent channel: This includes modification of the existing concrete channel to allow suitable conditions for restoration of freshwater marsh. Shallow water (< 6 feet) would be required for freshwater marsh, which would be interspersed with open water and riparian vegetation. Modifications to the channel include removal of concrete, excavation to create uneven bottom with pools and shallow zones, stabilization of the channel with boulders or weirs, and installation of wetland and riparian vegetation. The plant palette shown in Table 3.1, “Wetland Plant Palette,” will be used to vegetate wetland restoration areas.

Existing reaches that include wetlands and pools/riffles will be prototypes for what can be created in remaining river reaches. Several variables including flow velocities and sheer stress will be used to help define areas within the project area that are suitable for freshwater marsh and riparian habitat restoration.

For this sub-measure, a series of grade control structures made of grouted stone are proposed. When more detailed hydraulic design occurs, modification to the preliminary design will take place to create site-specific pool/riffle and weir configurations.

Table 3.1 Wetland Plant Palette

<i>Carex praegracilis</i>	clustered field sedge
<i>Cyperus odoratus</i>	fragrant flatsedge
<i>Eleocharis parishii</i>	Parish's spikerush
<i>Juncus effusus</i>	common rush
<i>Mimulus cardinalis</i>	scarlet monkeyflower
<i>Schoenoplectus californicus (Scirpus californicus)</i>	California bulrush
<i>Typha angustifolia</i>	narrow leaved cattail
<i>Typha latifolia</i>	common cattail

(4) Grade adjacent areas to lower elevation for habitat, floodplain reconnection, and offline retention: This sub-measure includes the lowering of specific sites adjacent to the channel to allow for retention of water and habitat creation. It would include excavation to create basins or terraces that tie into the channel and adjacent topography. Identified sites would be terraced with a 3H:1V or more gradual slope, and be planted with emergent and riparian vegetation.

(5) Create geomorphology for open water adjacent to the channel: This sub-measure is similar to sub-measure 3 but will include deeper water or open-water deeper than 6 feet, which would be absent of vegetation growth. Modifications to the channel would include the removal of concrete and excavation as needed for channel bed equilibrium. To achieve this sub-measure, the channel bottom would include boulders to stabilize bed material and weirs to slow in-stream velocities.

(6) Rebuild geomorphology for historic wash: This sub-measure includes the restoration of the Piggyback Yard (sub-reach 8) historic wash through the implementation of grading and excavation activities. Implementation of this sub-measure would require the removal of the existing industrial/railroad land use and associated contaminants.

Rebuilding the geomorphology of the historic wash would include creating channel banks with gradual (3H:1V or milder) slopes. Reshaping of the Piggyback Yard area would incorporate the reshaping of the historic wash itself along with adjacent areas supportive of habitat restoration. Terraces for the planting and establishment of riparian and buffer vegetation would occur towards the perimeter of the site. A list of recommended riparian and buffer vegetation can be found in Table 3.2, “Riparian and Buffer/Transitional Plant Palette.” Reshaping activities would extend from the River eastward to Interstate 5. Detailed site designs would be further developed during the final design phase of the study based upon more detailed hydraulic analysis.

Table 3.2 Riparian and Buffer/Transitional Plant Palette

Riparian	
<i>Ambrosia psilostachya</i>	western ragweed
<i>Artemisia douglasiana</i>	Mugwort
<i>Baccharis salicifolia</i>	Mulefat
<i>Mimulus cardinalis</i>	scarlet monkeyflower
<i>Platanus racemosa</i>	western sycamore
<i>Populus fremontii</i>	Fremont's cottonwood
<i>Salix laevigata</i>	red willow
<i>Salix lasiolepis</i>	Arroyo willow
Buffer/Transitional (minimal acreage)	
<i>Artemisia californica</i>	California sagebrush
<i>Eriogonum fasciculatum</i>	California buckwheat
<i>Eschscholzia californica</i>	California poppy
<i>Helianthus annuus</i>	Sunflower
<i>Leymus condensatus</i>	giant wild rye
<i>Lotus scoparius</i>	Deerweed
<i>Malacothamnus fasciculatus</i>	chaparral mallow
<i>Malosma laurina</i>	laurel sumac
<i>Rhus integrifolia</i>	lemonade berry
<i>Salvia apiana</i>	white sage

3.1.2 Attenuation

These measures include capture of flows from both the main channel and tributaries into surface and subsurface basins or channels. Potential sub-measures include the following:

(7) *Create underground basins for attenuation of flood flows:* This sub-measure consists of the construction of underground basins for attenuation of floodwaters and to provide temporary water supply for restoration. Six proposed locations include: Los Angeles Equestrian Center, Betty Davis Park, Ferraro Fields, Griffith Park, Bowtie Parcel, and Piggyback Yard. Preliminary design considerations for this feature include potential use of Contech's Stormtank® (or approved equivalent) water storage modules developed for sub-surface storm water detention and infiltration systems. It was estimated that up to 3,100 acre feet of storage could be created with implementing all sites.

Installation would require excavation of the site followed by covering with geotextile and filling with crushed stone. Existing land uses would be returned to the site after construction. The system is design to exceed HS-25 weight-loading criteria, and could be utilized under parking lots, athletic fields, parks, etc. The estimated depth of the storage modules would be 10 to 12 feet.

An analysis of the basin's ability to store floodwaters was conducted based on frequency hydrographs found in the 1992 LACDA Study. The analysis showed that the storage capacity of the basins would only provide a minor amount of peak flow reduction before the storage volume is completely utilized. In addition, water stored in underground basins would be difficult to off-load for water conservation activities due to the associated piping requirements and the existing high depth of groundwater in the channel area. The estimated preliminary cost of implementing this measure is \$1.3 billion or \$4.7 million per acre. Due to the low effectiveness and high cost of this sub-measure, it was dropped from further consideration.

(8) *Creation of attenuation basin with wetlands:* This sub-measure includes slowing input of storm flows and restoration of wetlands by creating storage at appropriate confluences with the River. Wetland attenuation basins would be sized to capture runoff from the local area (not the main channel) and would include a basin surrounded by terraced slopes. The basin would slow down flows before entering the main stem of the river system and would provide seasonal wetland habitat. Preliminary design includes excavation of a basin that would have an impermeable layer of either geotextile or fine materials installed. The basin would then be planted with wetland vegetation. Average depth of the basin is assumed to be 3 feet with depths ranging to 10 feet.

(9) *Diversion tunnels:* This sub-measure consists of the construction of a culvert (tunnel) beginning at the Headworks and extending downstream to Piggyback Yard to divert a minimum of 40,000 cfs from the channel during peak flow. The culvert would need to be designed to accommodate increasing flows from tributaries as it continues downstream. Preliminary costs were investigated for drilling four 24-foot-diameter tunnels to convey the discharge.

(10) Divert river and tributary flow into channels: This sub-measure includes diversion of either tributary or River flows into created channel or off-channel sites. Under this sub-measure, the installation of diversion structures and the grading and revegetation of the tributary or channel would be implemented. Further investigation would be required to design the site-specific diversions of water from the main channel at these sites.

This measure is currently proposed at seven sites within sub-reaches 1, 2, 3, 4, and 8. These include:

- Headworks area extending into Pollywog Park adjacent to the Burbank-Western Channel (1 site)
- Adjacent to Zoo Drive (2 sites)
- Adjacent to Ferraro Fields (1 site)
- Under the freeway and adjacent to the Wilson and Harding golf course (2 sites)
- Piggyback Yard (1 site)

3.1.3 Wildlife Access

These measures provide access and crossings for wildlife between the River and adjacent landscape. They include bridges, under-crossings, and tunnels.

(12) Bridge undercrossings for wildlife: Under this sub-measure, bridge under-crossings would be modified by installing corridors, which would allow wildlife crossing.

(13) Wildlife bridges: Under this sub-measure, vegetated wildlife bridges would be installed at identified sites to allow wildlife to pass across the channel or other impediments.

(14) Wildlife access from river to bank: Under this sub-measure, the slopes of channels would be re-graded to 3H:1V or milder to improve the ability of wildlife to ingress/egress along channel slopes.

(15) Wildlife passage into river: Under this sub-measure, modifications to storm drains and culverts would be implemented to allow wildlife passage. Activities under this sub-measure would include the widening and daylighting of tunnels and culverts where possible.

3.1.4 Planting

These measures would restore vegetation at various locations throughout the study area through revegetation of wetland, riparian, and buffer zones including bioengineering of channel walls and plantings within the channel bed wherever possible.

(16) Restructure/vegetate concrete channel walls: This sub-measure includes modification of the channel walls to allow the growth of vegetation. It could be accomplished through notching or inclusion of other structural changes such as terracing to allow vegetation growth. Plantings in

or at the tops of channel walls would require, at a minimum, temporary irrigation during habitat establishment.

In order to stabilize planting and reduce erosion potential, turf reinforcement mats (TRM) or an acceptable geotextile fabric is proposed for the design of this measure. The fabric is reported to withstand velocities of up to 20 feet/second and shear stress of up to 15 pounds/square foot and can be planted with vegetation (grasses and low shrubs). These are the current manufacturer's claims, and further analysis during detailed design as well as potential physical modeling would need to take place. To that end, the product and others that are similar are being tested by the Corps' Engineer Research and Development Center (ERDC).

(17) *Habitat corridors/Riparian planting:* Under this sub-measure, the creation of habitat corridors would include riparian vegetation planting on the riverbank and transitional vegetation on the overbank. Grading and modification of the top of the bank to tie created habitat into the adjacent river channel and proposed revegetation would occur. A list of recommended vegetation types for riparian and transitional zones can be found in Table 3.2.

(18) *Establish/improve open water habitat over concrete areas:* Currently, open water exists intermittently throughout the ARBOR reach albeit shallow with little habitat value. Using implementation actions included under sub-measures 3 and 5, modifications to create and/or improve open water conditions would include the restoration of freshwater marsh (sub-measure 3), the removal of channel bottom concrete (sub-measures 3 and 5), excavation of the channel bottom and placement of boulders for channel bed stabilization and the creation of pool and riffle zone habitat (sub-measure 5), and the construction of weirs to slow in-stream velocities (sub-measure 5).

(19) *Terrace concrete banks/planting built into channel walls:* This would include modifications to the channel walls to allow growth of vegetation. Concrete walls would be modified to add structures able to support vegetation. This could include constructed terraced habitat or openings in the concrete where vegetation is installed. Terraced banks are proposed where channel walls are sloped and have suitable space. Dimensions of the planters would be approximately 12 feet wide and 3 to 4 feet deep, and would be filled with soil for planting vegetation.

3.1.5 Remove Concrete

Concrete removal measures include modification of the channel by removal of concrete and/or grouted stone. It implies that erosion control would take place with any concrete removal that occurs due to modifications to the channel bed, terracing of the banks, etc.

(21) *Lower channel banks and widen:* This sub-measure includes lowering the channel banks and providing setback levees to provide more capacity for habitat. The widened area would only convey peak flows when the water surface exceeded the elevation of the lowered channel banks.

(23) *Channel bed deepening:* This sub-measure would consist of excavation of the channel bed to create more capacity for habitat. It would require the removal of the concrete invert and subsequent excavation of the channel bed and creation of a soft-bottom regime. The resulting

channel would need to be stabilized either through the reduction of flow or reduction of the channel grade. This sub-measure is combined with sub-measure 3 in most cases, which includes modification of the channel to provide suitable conditions for freshwater marsh habitat.

(26) Terraces with earthen banks: This sub-measure consists of terracing the channel banks to provide step-like structures in place of current slopes. The terraced configuration would consist of planter-box type structures filled with soil to allow habitat planting. Terraces and the soil would need to be stabilized for flood flows and safety.

3.1.6 Reshape Channel

This measure is proposed in several sub-reaches of the study area. Reshaping of the channel would increase channel capacity and create geomorphic features that would support riverine habitat. This measure includes modification of the trapezoidal channel to vertical sides to increase channel capacity and cantilevering the top-of-bank surface over the channel walls to provide additional channel capacity.

(27) Modify trapezoidal channel to vertical, widening the channel: This sub-measure would remove the existing trapezoidal channel walls and widen the channel by constructing vertical walls. To implement this measure, demolition and excavation of the existing trapezoidal channel banks would occur, and vertical walls with footings and toe protection would be constructed.

(28) Cantilever channel bank: This sub-measure includes the widening of the channel and construction of an overhanging, cantilevered top-of-bank section. Demolition and rebuilding of the channel and adjacent infrastructure would occur. The cantilevered bank sections would include overhanging walkways or promenades tied to hiking trails and adjacent streets while providing additional channel capacity underneath the overbank.

3.2 Preliminary Ecosystem Restoration Alternatives

The above measures and sub-measures, and a set of initial alternatives, were developed during charette workshops held December 2-4, 2009. Alternatives were subsequently evaluated and additional alternatives developed for a total of 19 preliminary alternatives, as shown in Table 3.3. It should be noted that implementation of some alternatives would be dependent on the diversion of flood flows from this reach of the river. That analysis is described in the main report and the descriptions in Section 4 assume that diversion would be in place, if required. However, the diversion tunnel and alternatives dependent on it were not cost effective and, therefore, none of the final alternatives found in Section 6 require a tunnel.

Table 3.3 Preliminary Array of 19 Alternatives

No.	Alternative	Description
0	No Action	Future Without-Project Conditions
1	Comprehensive A	Includes development of freshwater marsh, open water ponds, fish refugia, and riparian corridors, exposing storm drain outlets and converting to natural stream confluences, diversion of flow into side channels lined with habitat, underground basins and culverts to attenuate flow, bioengineering of channel walls, channel modification to increase width by terracing, channel widening, and/or modification of channel walls, connections to green streets, modification along tributary confluences to more natural habitat, and wildlife crossings.
2	Atwater to Cornfields (Developed by City)	Implements all of the above within the Atwater to Cornfields part of the reach.
3	Banks & Tributaries Only	Leaves the flood control channel bed primarily “as is” and restores floodplain by creating side channels in open areas along the river with freshwater marsh and riparian corridors and restoring tributary confluences. Includes modification of storm drain outlets and bank terracing.
4	Comprehensive B (developed based on measures with objectives scores over 3)	Includes most of measures included in Alt 1 Comprehensive A with fewer locations, less terracing and side channels, and omits elevating railroads on trestles, bioengineering walls, open water, and modifying trap channel to vertical.
5	Los Feliz to Arroyo Seco (Developed by City)	Implements all measures within Los Feliz to Arroyo Seco reach.
6	Comprehensive C (developed by USACE)	Includes most of measures included in Alt 1 Comprehensive A with fewer locations and omits railroad elevation, bioengineering walls, open water, and modifying trap channel to vertical. Includes more terracing and storm drain modifications and different locations for wildlife crossings than Alt 4 Comprehensive B.
7	Channel Reshaping A (developed based on measures with objectives scoring over 5)	Focus is on channel reshaping and attenuation of flow – detention, bypass and widening. Using culverts and underground basins to attenuate flows, the channel is geomorphically changed to a wider, softer channel, naturalized storm drain outlets, and some restored riparian corridors.
8	Habitat Variation (Derived from Charette Team 1)	Maximizing habitat restoration for a species diversity, including fish, motivated formulation of alternative. Attenuation or reduction in flow is included in each reach as well as freshwater marsh, riparian and aquatic habitat measures.
9	Soft Bottom Channel & Associated Banks	This alternative focuses restoration in reaches that already have a soft riverbed. Where open areas are adjacent to the river, the river will be widened rather than terraced. Storm drains are converted to natural stream confluences and restored with vegetation. Habitats include aquatic, freshwater marsh and riparian areas.
10	Channel Modifications with least structural and engineering impacts and public acceptability (based on scores for each measure under this criteria)	This alternative implements measures in locations with the least impact to infrastructure and engineering challenges, while still including measures in all reaches to attenuate flow, restore riparian and freshwater marsh habitat and tributary confluence restoration.
11	Habitat Connectivity (Derived from Charette Team 4)	This alternative focuses on bank to bank and upstream to downstream connections for wildlife, linkages to wildlife areas, channel widening and terracing.

No.	Alternative	Description
12	Hydrologic Connection Improvements (Derived from Charette Team 3)	This alternative focuses on lowering grade for adjacent large open areas, improved hydrologic connections between the banks, storm drains and the river. It also intends to increase wildlife movement between the river and adjacent open areas.
13	Channel Reshaping B (Derived from Charette Team 6)	Using culverts to attenuate flows, the channel is geomorphically changed to a wider, softer channel, naturalized storm drain outlets, and restored riparian corridors. Includes bioengineering of channel walls, side channels and has more riparian and freshwater marsh replanting than Channel Reshaping A.
14	Channel Widening(Derived from Charette Team 5)	This alternative focuses on widening the channel. Attenuation is accomplished with culvert bypasses. Includes planting of freshwater marsh and riparian corridors.
15	Bypass with Bank and Tributary Confluence Restoration (Derived from Charette Team 2)	Reduces flow using culvert bypass to allow for terracing and channel bank softening. Improves freshwater marsh habitat in soft bottom area and adds riparian habitat to downstream locations on the river overbank. Emphasizes widening and restoration at tributary confluences.
16	Side Channels Only	Leaves the flood control channel bed and banks primarily “as is,” and restores floodplain by creating side channels in open areas along the river with freshwater marsh and riparian corridors and restoring tributary confluences.
17	Opportunity area restoration with channel widening at tributaries (Derived from Charette Team 7)	Restores wetlands on the overbank and major tributaries at River Glen - Verdugo Wash confluence, Griffith Park, Bowtie/Taylor Yard, Arroyo Seco confluence, Burbank Western Channel, Cornfields (Los Angeles Historical Park) and the Piggyback Yard (Mission Yard). Widens the river at Verdugo, Arroyo Seco and Burbank Western Channel.
18	Opportunity area restoration to large open areas	Leaves flood control channel bed and banks “as is” and restores wetlands on the overbank and major tributaries at River Glen - Verdugo Wash confluence, Bowtie/Taylor Yard, Arroyo Seco confluence, and Cornfields (Los Angeles Historic Park).
19	Taylor Yard	Restores wetlands on the overbank and widens the river at this single key location on the river (includes the Bowtie parcel).

4. PRELIMINARY FEASIBILITY DESIGNS

Conceptual designs were developed for the measures described in Section 3 for the purpose of developing quantities and costs and comparing alternatives. They are not intended to be final designs, and only typical cross-sections were developed for this effort. Typical cross-sections were developed for each of the study sub-reaches; cross-section locations throughout the study area are shown in Figure 4.1. These cross-sections include major features found in each of the sections noted and include multiple measures, which may not be present in each alternative.

During the formulation and analysis of alternatives it was assumed that the implementation of several of these would require tunnels to divert flood flows. The description of those alternatives and reaches that are assumed to require tunnels for implementation is described in the plan formulation section of the main feasibility report.

4.1 Assumptions and Limitations

Designs are based on preliminary, planning-level conceptual designs, and common engineering practices. The development of the preliminary designs took place prior to hydraulic and geotechnical design information. Design parameters for such things as velocities, shear stress, erosiveness, etc., were not provided at the time the preliminary designs were developed. Future design phases would be more integrated with the hydraulic analysis, geotechnical analysis, and vegetation requirements such that the concepts shown and discussed herein may be modified if necessary.

Several assumptions were developed during the preliminary design in order to complete the design and cost estimate. The riprap was conceptually sized in accordance with USACE's methodology and the TRM in accordance with the manufacturer's recommendation. Because of a lack of clear design parameters including the aforementioned hydraulic and geotechnical analyses, the designs and dimensions shown below are approximate in nature and are subject to reanalysis during the final design phase.

Turf Replacement Matting and Riprap Protection – The existing bank grouted rock or concrete slope protection would be removed and replaced by a 3H:1V combination of high performance TRM, or acceptable geotextile, and riprap system. A riprap layer was provided at the bottom river bank for higher flow velocity protection. In addition, the riprap extends an assumed 10 feet below the river invert for scour protection. This assumption was conservatively based on the existing toe protection, which in most cases is a 3-5 foot deep grouted section and sometimes includes a 10-15 foot deep sheet pile. Above the riprap, the river bank is lined with a high performance TRM to protect against erosion potential and to allow for acceptable vegetation growth.

Reinforced Concrete Retaining Wall – The existing bank grouted rock or concrete slope protection would be removed and replaced by a reinforced concrete retaining wall system. The 22-foot-high reinforced concrete wall was conceptually sized per the California Department of Transportation's (Caltrans) Type 1 Retaining Wall specifications, having a 13-foot-wide footing. A horizontal layer of riprap with a 10-foot toe-down was assumed to provide erosion protection.

Terraced Banks and Riprap Protection – The existing bank grouted rock or concrete slope protection would be removed and replaced by a 3H:1V combination of terraces and riprap system. A riprap layer was provided at the bottom river bank for higher flow velocity protection. In addition, the riprap extends an assumed 10 feet below the river invert for scour protection. Above the riprap, the river bank would be protected by four reinforced concrete terraces anchored to the channel slope. The terraces would provide additional bank substrate for acceptable vegetation planting/establishment and would protect against potential erosion.

4.2 Cross-Sections

This section describes each cross-section illustrated in the preliminary design array. Typical cross-sections for measures included in the preliminary alternatives were developed to:

- Determine the feasibility of preliminary design measures
- Provide depictions of preliminary design measures
- Facilitate quantity and cost estimation

In addition, cross-sections representing revisions to the preliminary design array that were developed as part of the final array of alternatives described in Section 6, below, may be found in Attachment 4.

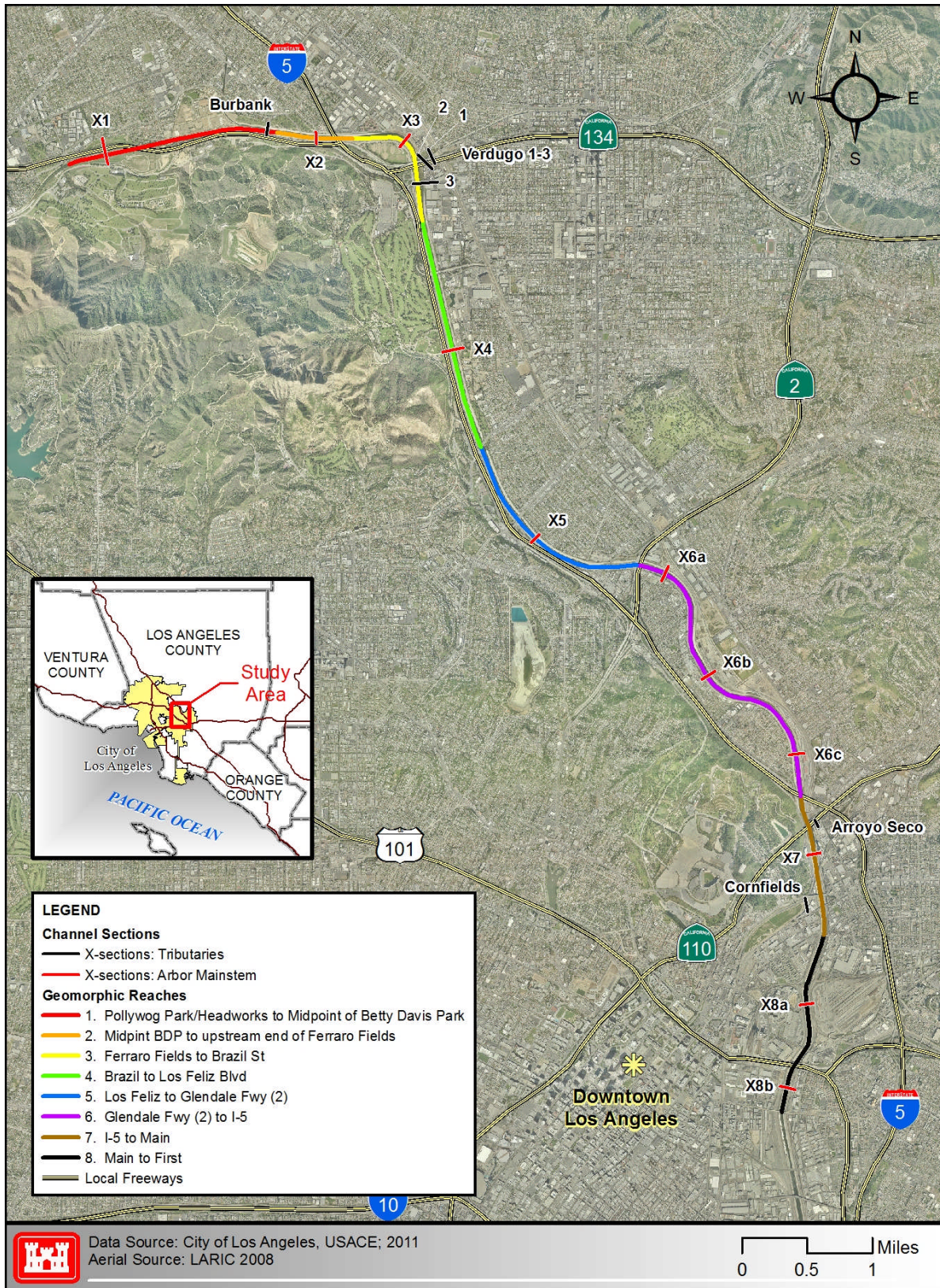

Figure 4.1 Preliminary Design Cross-Section Locations by Sub-reach

4.2.1 Cross-Section 1, Sub-Reach 1 - Pollywog Park/Headworks to Midpoint of Betty Davis Park

Existing Channel Features – The existing rectangular reinforced concrete channel is 130 feet wide and 18 feet high from the invert, with subdrain systems underneath the invert slab.

Preliminary Channel Design – As seen in Figure 4.2, “Cross-Section 1, Pollywog Park/Headworks to Midpoint of Betty Davis Park,” the proposed design would widen the channel by 51 feet by replacing the existing vertical concrete retaining wall with a combination of TRM and riprap on 3H:1V slopes on the left/north bank of the channel. The right/south bank would be sloped 3H:1V, starting 3 feet from the top of the channel. The existing concrete channel bottom would be replaced by soft “natural” substrate. A toedown structure with added bank protection would be constructed at the toe of the proposed left/north bank. Grade control structures would be constructed to reduce in-stream velocities and secure natural bed materials for meander and vegetation development.

Demolition and Excavation – Several areas of the reach would undergo demolition and excavation to implement the proposed design. The concrete channel bottom, the top 3 feet of the left/north bank retaining wall, and the right/south bank concrete retaining wall would be demolished. The remainder of the left/north bank retaining wall would be protected in place. Excavation of earthen material would occur behind the removed left/north bank retaining wall and behind the removed upper portion of the right/south bank retaining wall. In areas where grade control structures would be implemented, an additional 10 to 15 feet of earthen material would be excavated from the channel bed to accommodate construction of grouted riprap toedowns. Excavation at a depth of 3 to 10 feet and a width of 20 feet would be conducted for the left/north bank toedown.

Compacted Fill and Maintenance Road – Compacted fill would be used to fill behind the left/north and right/south channel top of banks. The compacted fill would be used to create a 16-foot wide maintenance road. The maintenance road would be paved with asphalt-concrete that would meet the proposed channel’s TRM and vegetated 3H:1V slope on the river, and compacted fill on the 3H:1V slope landward. Fencing would be constructed to separate areas of access from the maintenance road, on both the potentially private right-of-way, and the river.

Erosion Control – Erosion control matting, TRM, or approved equivalent geotextile mats would be used to stabilize, prevent channel scour, and to promote vegetation establishment on channel slopes.

Topsoil and Vegetation – Topsoil would aid in the recruitment and establishment of vegetation along the channel’s riparian zone. Topsoil would be placed on the slopes of the maintenance road compacted fill and along the channel’s 3H:1V slopes after TRM matting has been installed. Topsoil areas would be seeded and planted with native riparian vegetation as listed in Table 3.2.

Grade Control Structure – Grouted riprap grade control structures would be constructed every 500 feet along this reach of the channel. Grade control structures would reduce in-stream flow velocities and stabilize the channel’s slope and earthen bed material. Grade control structures would be constructed in the channel bottom at a depth of 10 or 15 feet, have a 2H:1V slope on the upstream end and a 4H:1V slope on the downstream end, be 5 feet in width on top, and have a 2-foot-deep and 20-foot-wide low-flow centerline notch.

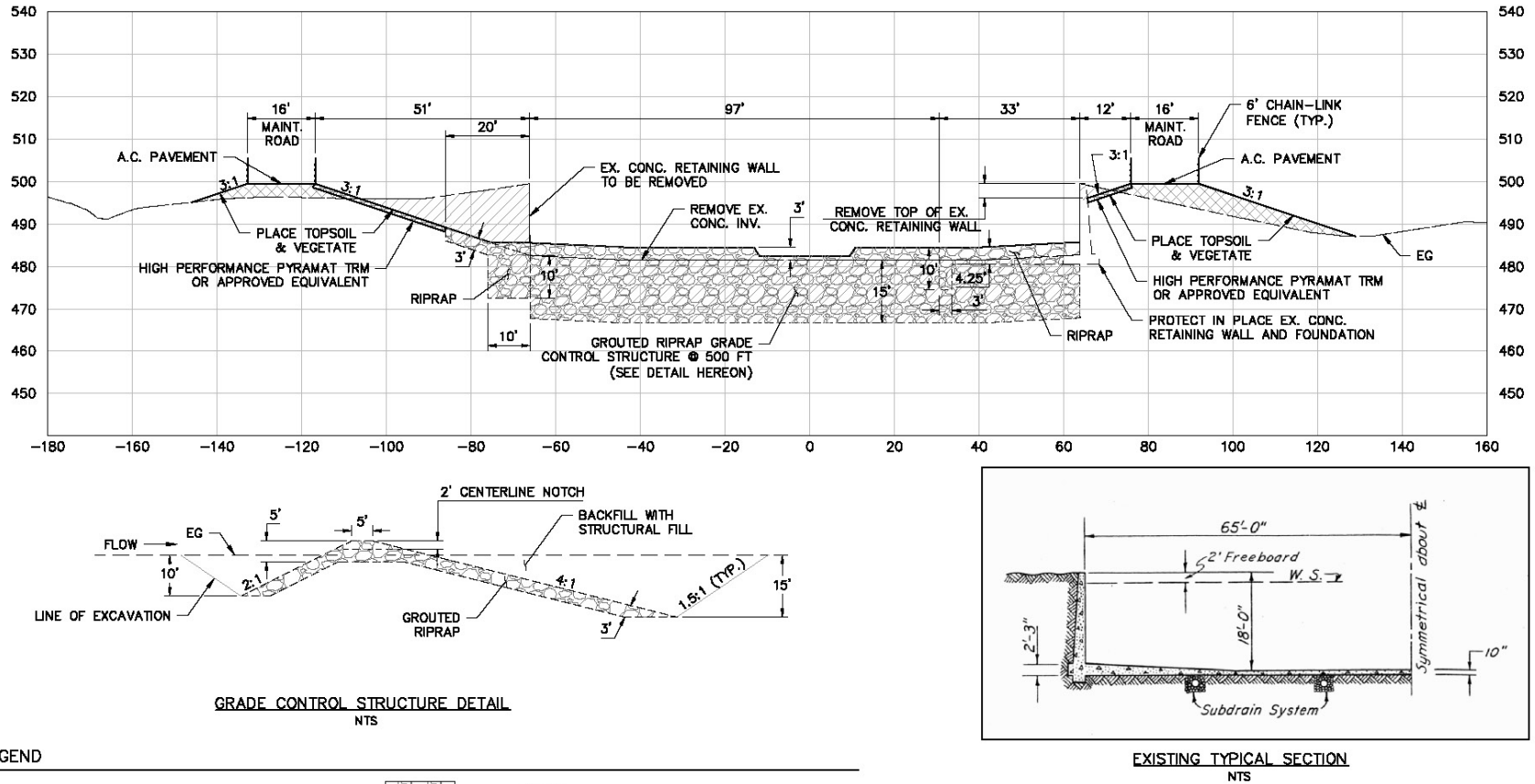

Figure 4.2 Cross-Section 1, Pollywog Park/Headworks to Midpoint of Betty Davis Park

4.2.2 Burbank-Western Channel Cross-Section, Sub-Reach 1 - Confluence at the Los Angeles River

Existing Channel Features – The existing rectangular reinforced concrete channel is 60 feet wide and 18 feet high from the invert.

Preliminary Channel Design – As seen in Figure 4.3, “Burbank-Western Channel Cross-Section,” the proposed design would widen the left/north top of bank of the channel by 188 feet. The proposed left/north bank would have an 8H:1V vegetated slope. A soft-bottom vegetated wetland would be constructed in the widened portion of the channel bottom. Two riprap toedowns would be constructed below the channel bottom and banks. The first riprap toedown would be located at the in-channel edge of the proposed wetland at a depth and width of 10 feet. The second riprap toedown, with additional bank protection, would extend landward from the toe of the proposed left/north bank at a depth of 3 to 10 feet and a width of 20 feet. A 16-foot-wide asphalt concrete maintenance road would be constructed on the proposed left/north top of bank.

Demolition and Excavation – The left/north concrete retaining wall would be demolished. The channel bottom would be excavated to a width of 60 feet; an 8H:1V channel bank would be excavated for an additional 88 feet to meet the existing ground above.

Compacted Fill and Maintenance Road – The existing ground at the left/north top of bank would be used as the base of the proposed 16-foot-wide asphalt concrete maintenance road. Fencing would be constructed to separate areas of access from the maintenance road, on both the potentially private right-of-way, and the river.



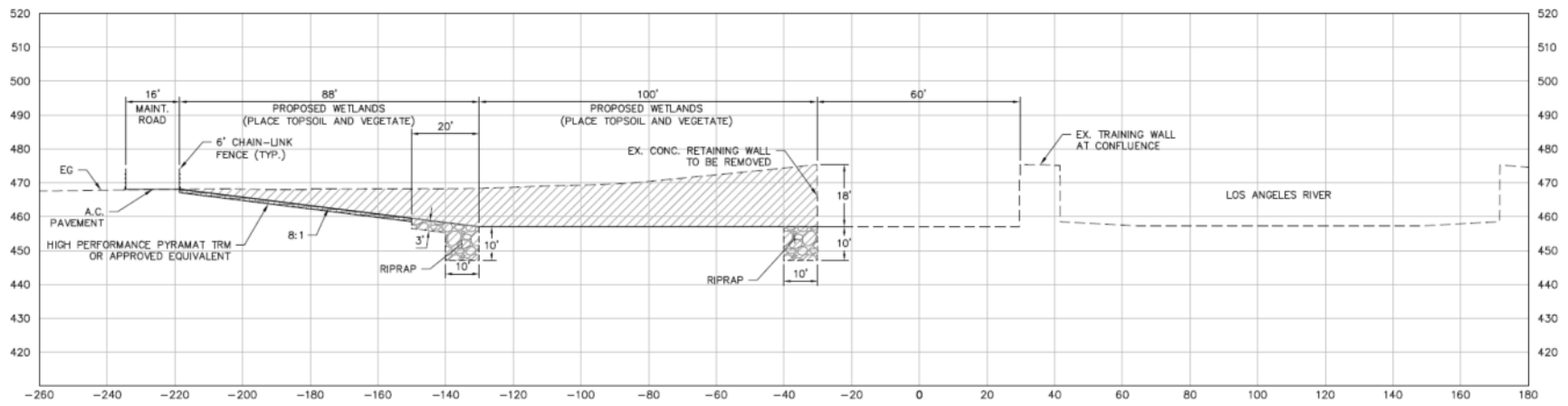

Wetlands – The wetlands would extend for a distance of 188 feet from the edge of the concrete channel bottom (where the retaining wall is to be removed) to the proposed right/west bank toe. The wetland area would spread channel flows and slow in-stream flow velocities, assist in treating pollutants, and create riverine wetland habitat for wildlife and aesthetics.

Erosion Control – Erosion control matting, such as TRM, would be used to stabilize, prevent channel scour, and to promote vegetation establishment on the left/north channel slope.

Topsoil and Vegetation – Topsoil would aid in the recruitment and establishment of vegetation along the channel’s riparian zone. Topsoil would be placed on the left/north bank slope after TRM matting is installed. Topsoil would also be placed in the wetlands area. Topsoil areas would be seeded and planted with riparian vegetation on the banks and wetland vegetation in-channel per recommendations of the project biologist.



LEGEND

---	EX. GROUND		RIPRAP
—	PROPOSED CHANNEL		REINFORCED CONCRETE
	EXCAVATION		HIGH PERFORMANCE PYRAMAT TURF REINFORCEMENT MAT (TRM) OR APPROVED EQUIVALENT
	COMPACTED FILL		

NOTE: ALL DIMENSIONS SHOWN ARE APPROXIMATE AND SUBJECT TO REVISIONS DURING FINAL DESIGN

Figure 4.3 Burbank-Western Channel Cross-Section

4.2.3 Cross-Section 2, Sub-Reach 2 - Midpoint of Betty Davis Park to Upstream End of Ferraro Fields

Existing Channel Features – The existing trapezoidal reinforced concrete/grouted rock channel with cobblestone soft bottom is 300 feet wide from the top of bank and 16 feet above the invert.

Preliminary Channel Design – As seen in Figure 4.4, “Cross-Section 2, Midpoint Bette Davis Park to Upstream of Ferraro Fields,” the proposed design would widen the left/north top of bank by 10 feet, and would have a 3H:1V slope stabilized by erosion control matting and vegetation. The toe of the right/south bank would be widened by 60 feet, where a 22-foot-high vertical retaining wall with subdrainage system would be constructed. A toedown structure with added bank protection would be constructed at the toe of the proposed left/north bank. The existing cobble bottom would be protected in place. Grade control structures would be constructed to reduce in-stream velocities and secure natural bed materials for meander and vegetation development.

Demolition and Excavation – Several areas of the reach would undergo excavation to implement the proposed design. The left/north bank’s existing grouted riprap or concrete slope protection would be excavated to widen the channel by 10 feet. The right/south bank’s existing grouted riprap or concrete slope protection would be excavated to widen the channel by 60 feet. Additional excavation would occur behind the proposed retaining wall, and would have a temporary slope of 1.5H:1V to meet the existing ground; excavation would allow temporary access for construction of the retaining wall. In areas where grade control structures would be implemented, an additional 10 to 15 feet of channel bottom would be excavated to accommodate construction of grouted riprap toedowns and retaining wall footings.

Compacted Fill and Maintenance Road – After construction of the retaining wall, compacted fill would be placed and compacted behind the right/south channel top of bank to create a 16-foot-wide paved asphalt-concrete maintenance road. Compacted fill would also be placed on the land of the maintenance road and sloped 3H:1V to meet the existing ground. The left/north top of bank maintenance road would use the existing ground as a base. Fencing would be constructed to separate areas of access from the maintenance road, on both the potentially private right-of-way, and the river.

Erosion Control – Erosion control matting, such as TRM, would be used to stabilize, prevent channel scour, and to promote vegetation establishment on channel slopes.

Topsoil and Vegetation – Topsoil would aid in the recruitment and establishment of vegetation along the channel’s riparian zone. Topsoil would be placed over TRM on the right/south bank channel slope and the left/north bank maintenance road slope. Topsoil areas would be seeded and planted with native riparian vegetation per the project biologist’s recommendations.

Grade Control Structure – Grouted riprap grade control structures would be placed every 500 feet along this reach of the channel. Grade control structures would reduce in-stream flow velocities and stabilize the channel's slope and earthen bed material. Grade control structures would be constructed in the channel bottom at a depth of 10 or 15 feet, have a 2H:1V slope on the upstream end and a 4H:1V slope on the downstream end, be 5 feet in width on top, and have a 2-foot-deep and 20-foot-wide low-flow centerline notch.

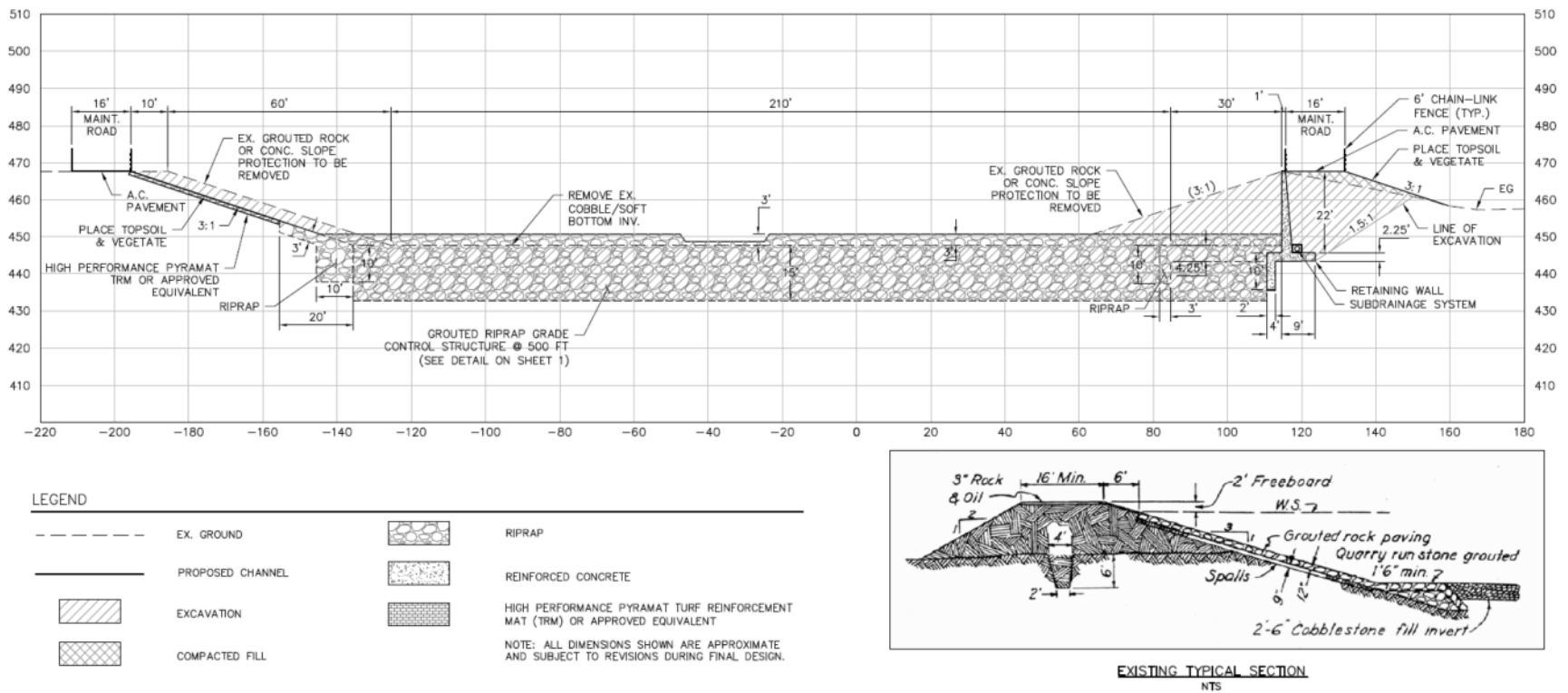

Figure 4.4 Cross-Section 2, Midpoint Bette Davis Park to Upstream of Ferraro Fields

4.2.4 Cross-Section 3, Sub-Reach 3 - Ferraro Fields to Brazil Street

Existing Channel Features – The existing trapezoidal reinforced concrete/grouted rock paving channel with concrete bottom, and 3H:1V slopes, is 280 feet wide from the top of bank, and approximately 21 feet high from the invert.

Preliminary Channel Design – As seen in Figure 4.5, “Cross-Section 3, Ferraro Fields to Brazil Street,” the proposed design would construct two 23-foot-high retaining walls with subdrainages, on the left/east and right/west banks of the channel. Riprap toedowns would be placed at the toe of the retaining walls. Two concrete reinforced planter boxes (naturalized channel) on the left/north and right/south banks would be constructed at the edge of the toedown and extend 50 feet towards the centerline of the channel. Two 16-foot-wide asphalt concrete maintenance roads would be constructed on the top of the channel’s banks. The existing low-flow channel and concrete bottom would be protected in place.

Demolition and Excavation – Several areas of the reach would undergo demolition and excavation to implement the proposed design. The right/west bank and the left/east bank existing trapezoidal grouted riprap or concrete paved slope protection would be demolished; 74 feet of the concrete channel bottom would be demolished for construction of the naturalized channel. Excavation would widen the channel bottom by 48 feet on both banks and would occur behind the proposed location of the retaining walls and would have a temporary slope of 1.5H:1V to meet the existing ground; excavation would allow temporary access for construction of the walls. The proposed toedown locations would be excavated to a depth of 4.25 to 10 feet and a width of 30 and 33 feet at the toe of the left/east and right/west retaining walls respectively. The naturalized channel and concrete footing locations would be excavated to a depth of 12 feet and a width of 50 feet at the edge of the toedowns towards the center of the channel.



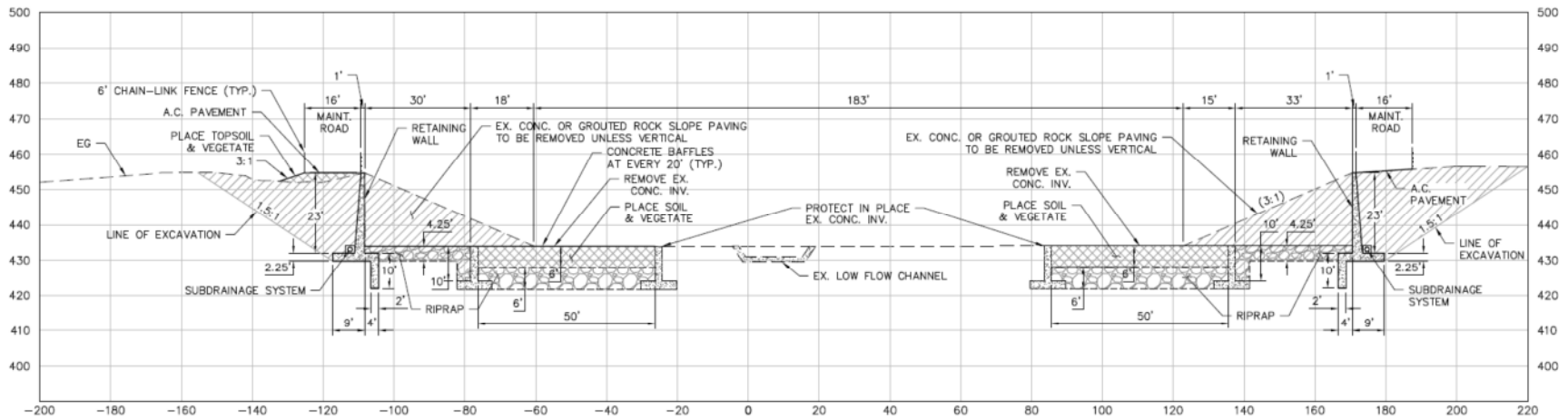

Compacted Fill and Maintenance Road – After construction of the retaining walls, compacted fill would be placed and compacted behind the left/north and right/south channel’s retaining walls. The fill would be placed to accommodate a 16-foot-wide paved asphalt-concrete maintenance road on both banks. The land compacted fill on the right/south bank maintenance road would be sloped 3H:1V to meet the existing ground. Fencing would be constructed to separate areas of access from the maintenance road, on both the potentially private right-of-way, and the river.

Planter Boxes (Naturalized Channel) – Naturalized channel would be constructed at the edge of the retaining wall toedowns and would extend 50 feet into the center of the channel at a depth of 12 feet. The surface of the naturalized channel would be flush to the existing channel concrete bottom. The bottom 6 feet of the naturalized channel would be filled with riprap. The top 6 feet of the planter boxes would be filled with soil and secured with concrete baffles to prevent scour/erosion. They would also include drainage holes to help route drainage water from upper boxes to lower boxes.

Topsoil and Vegetation – Topsoil would aid in the recruitment and establishment of vegetation along the channel’s riparian zone. Topsoil would be placed on the right/south bank of the maintenance road and the two sections of naturalized channel. Topsoil areas would be seeded and planted with transitional zone vegetation on the top of the maintenance road and riparian/wetland vegetation in the channel as recommended by the project biologist.



LEGEND

---	EX. GROUND		RIPRAP
—	PROPOSED CHANNEL		REINFORCED CONCRETE
	EXCAVATION		HIGH PERFORMANCE PYRAMAT TURF REINFORCEMENT MAT (TRM) OR APPROVED EQUIVALENT
	COMPACTED FILL		

NOTE: ALL DIMENSIONS SHOWN ARE APPROXIMATE AND SUBJECT TO REVISIONS DURING FINAL DESIGN.

Figure 4.5 Cross-Section 3, Ferraro Fields to Brazil Street

4.2.5 Verdugo Wash Cross-Section 1, Sub-Reach 3 - Upstream of the Los Angeles River Confluence

Existing Channel Features – The existing rectangular reinforced concrete channel is 110 feet wide and 28 feet high from the invert.

Preliminary Channel Design – As seen in Figure 4.6, “Verdugo Wash Cross-Section 1, Upstream of Los Angeles River Confluence,” the proposed design would widen the left/south top of bank of the channel by 389 feet, and construct a 119-foot-wide 3H:1V benched/terraced vegetated slope. The proposed widened section of the channel would be soft bottom. Two riprap toedowns would be constructed below the channel bottom and bank. The first riprap toedown would be located at the edge of the proposed widened portion of the channel at a depth and width of 10 feet. The second riprap toedown, which would include bank protection along the base of the proposed left/east bank, would be at a depth of 3 to 10 feet and a width of 20 feet. A 16-foot-wide asphalt concrete maintenance road would be constructed on the proposed left/east top of bank.

Demolition and Excavation – The left/south concrete retaining wall would be demolished. The channel bottom would be excavated to a width of 270 feet; a 3H:1V terraced/benched channel bank would be excavated for an additional 135 feet to meet the existing ground above. Excavation for riprap toedowns would occur at the toe of the proposed left/south bank and at the edge of where the widened and existing concrete channel bottoms would meet, at a depth of 3 to 10 feet.

Compacted Fill and Maintenance Road – The existing ground at the left/east top of bank would be used for the base of the proposed 16-foot-wide asphalt concrete maintenance road. Fencing would be constructed to separate areas of access from the maintenance road, on both the potentially private right-of-way, and the river.

Erosion Control – Erosion control matting, such as TRM, or approved equivalent, would be used to stabilize, prevent channel scour, and to promote vegetation establishment on the left/south channel slope.

Topsoil and Vegetation – Topsoil would aid in the recruitment and establishment of vegetation along the channel’s riparian zone. Topsoil would be placed on the left/south bank and after TRM matting is installed. Topsoil areas would be seeded and planted with recommended vegetation.

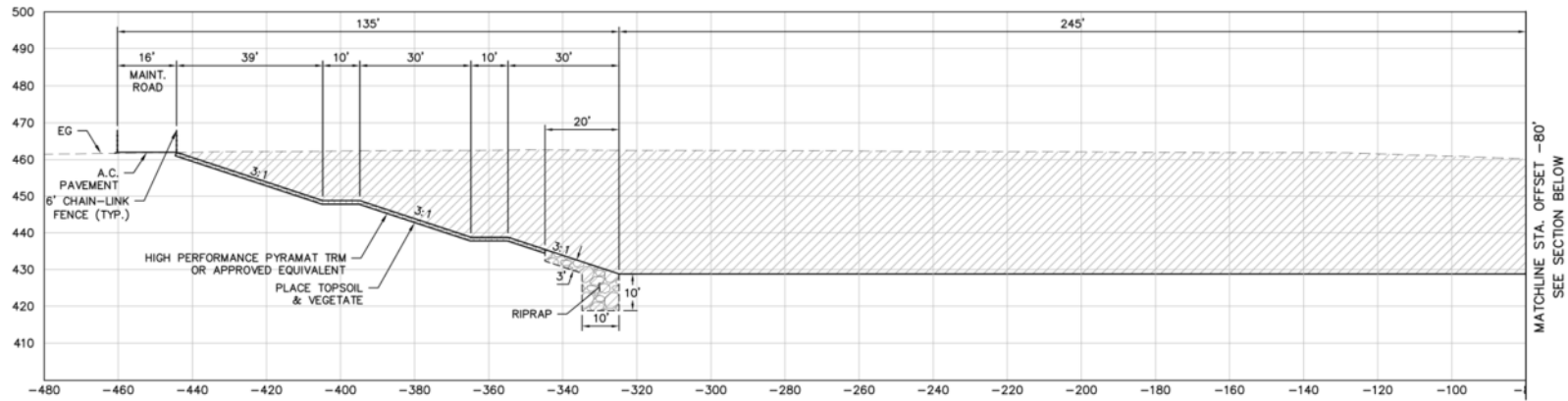

LEGEND

	EX. GROUND		RIPRAP
	PROPOSED CHANNEL		REINFORCED CONCRETE
	EXCAVATION		HIGH PERFORMANCE PYRAMAT TURF REINFORCEMENT MAT (TRM) OR APPROVED EQUIVALENT
	COMPACTED FILL		

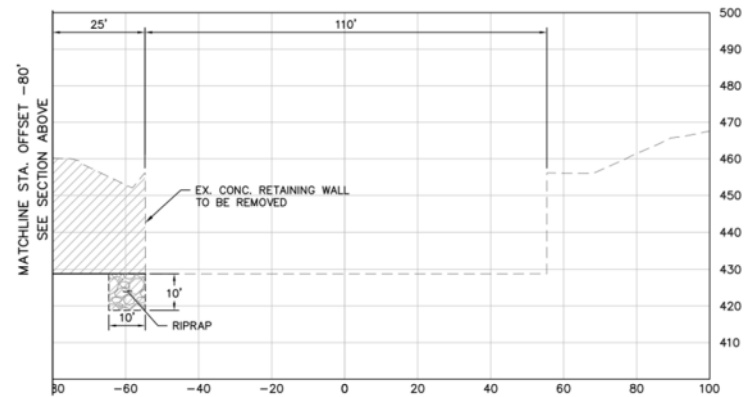

Figure 4.6 Verdugo Wash Cross-Section 1, Upstream of Los Angeles River Confluence

4.2.6 Verdugo Wash Cross-Section 2, Sub-Reach 3 - Upstream of Los Angeles River Confluence

Existing Channel Features – The existing rectangular reinforced concrete channel is 90 feet wide and 24 feet high from the invert.

Preliminary Channel Design – As seen in Figure 4.7 and Figure 4.8, “Verdugo Wash Cross-Section 2, Upstream of Los Angeles River Confluence,” the proposed design would widen the left/south top of bank of the channel by 647 feet, and construct a 129-foot-wide 3H:1V benched/terraced vegetated slope. Benching on the slope would be 10 feet wide and occur at 30 and 70 feet from the toe. The proposed widened section of the channel would be soft bottom. Two riprap toedowns would be constructed below the channel bottom and banks. The first riprap toedown would be located at the edge of the proposed widened portion of the channel at a depth and width of 10 feet. The second riprap toedown, which would include bank protection along the base of the proposed left/south bank, would be at a depth of 3 to 10 feet and a width of 20 feet. A 16-foot-wide asphalt concrete maintenance road would be constructed on the proposed left/east top of bank.

Demolition and Excavation – The left/east concrete retaining wall would be demolished. The channel bottom would be excavated to a width of 534 feet; a 3H:1V terraced/benched channel bank would be excavated for an additional 113 feet to meet the existing ground above. Excavation for riprap toedowns would occur at the toe of the proposed left/east bank and at the edge of where the widened and existing concrete channel bottoms would meet, at a depth of 3 to 10 feet.

Compacted Fill and Maintenance Road – The existing ground at the left/south top of bank would be used as the base of the proposed 16-foot-wide asphalt concrete maintenance road. Fencing would be constructed to separate areas of access from the maintenance road, on both the potentially private right-of-way, and the river.

Erosion Control – Erosion control matting, such as TRM, or approved equivalent, would be used to stabilize, prevent channel scour, and to promote vegetation establishment on the left/south channel slope.

Topsoil and Vegetation – Topsoil would aid in the recruitment and establishment of vegetation along the channel’s riparian zone. Topsoil would be placed on the left/south bank after TRM matting is installed. Topsoil areas would be seeded and planted with riparian vegetation per recommendation of the project biologist.

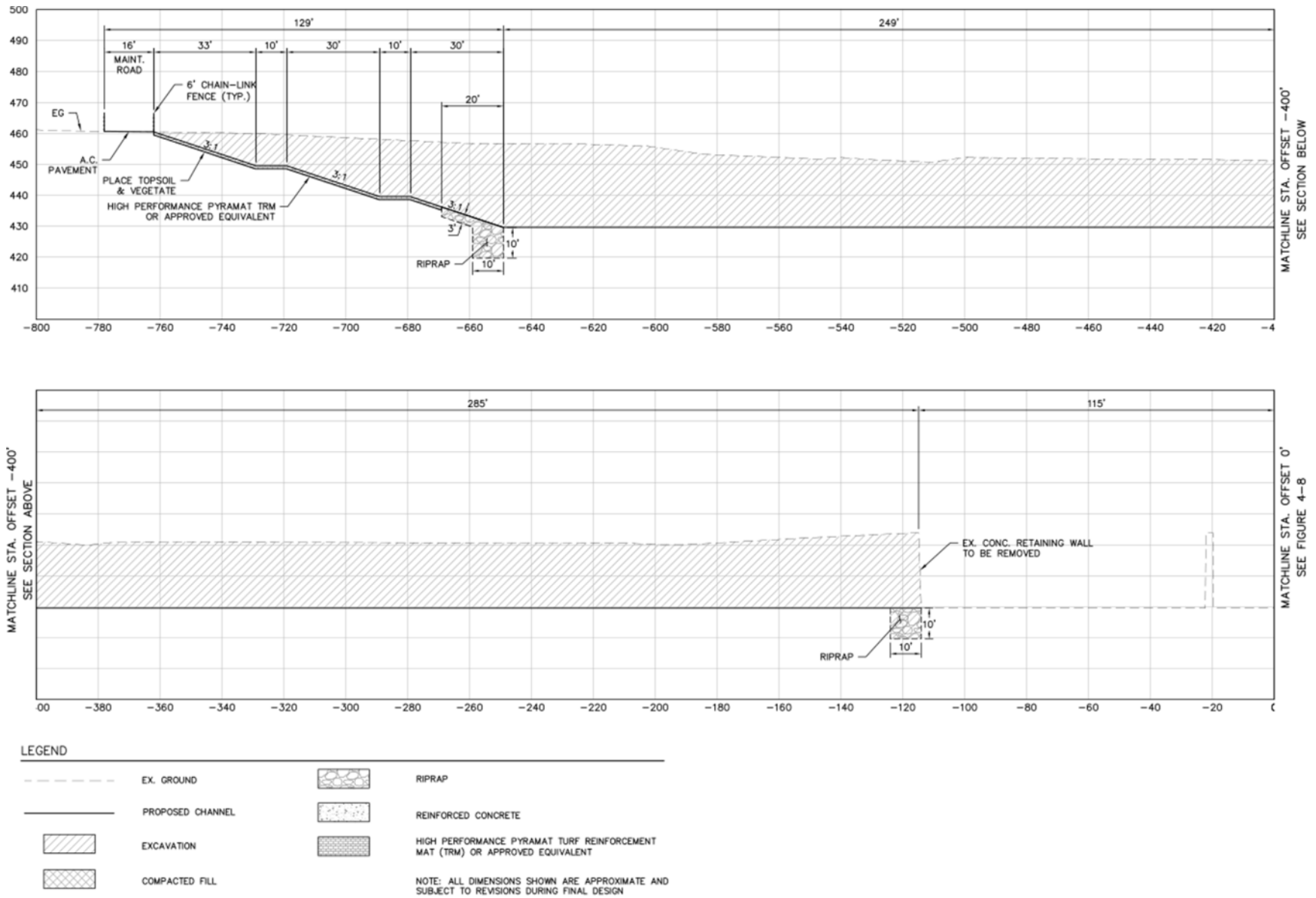
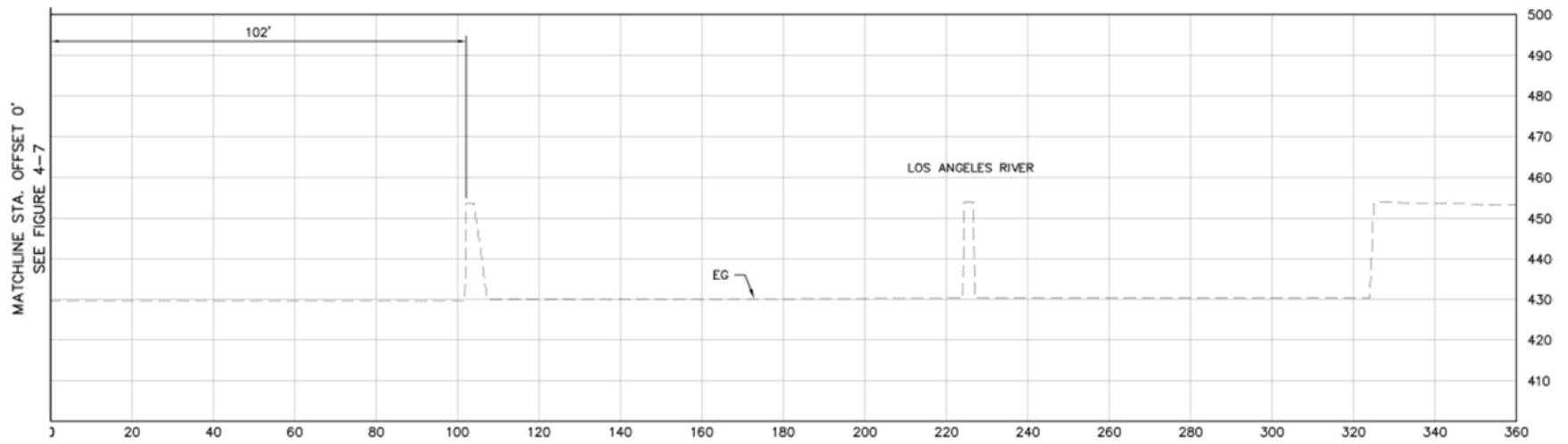







Figure 4.7 Verdugo Wash Cross-Section 2, Upstream of Los Angeles River Confluence



LEGEND

---	EX. GROUND		RIPRAP
—	PROPOSED CHANNEL		REINFORCED CONCRETE
	EXCAVATION		HIGH PERFORMANCE PYRAMAT TURF REINFORCEMENT MAT (TRM) OR APPROVED EQUIVALENT
	COMPACTED FILL		

NOTE: ALL DIMENSIONS SHOWN ARE APPROXIMATE AND SUBJECT TO REVISIONS DURING FINAL DESIGN

Figure 4.8 Verdugo Was Cross-Section 2 (cont'd), Upstream of Los Angeles River Confluence

4.2.7 Verdugo Wash Cross-Section 3, Sub-Reach 3 - Los Angeles River Confluence

Existing Channel Features – The existing rectangular reinforced concrete channel is at the confluence of Verdugo Wash and the Los Angeles River. The width of the existing channel is 389 feet wide and 25 feet high from the invert.

Preliminary Channel Design – As seen in Figure 4.9 and Figure 4.10, “Verdugo Wash Cross-Section 3, Upstream of Los Angeles River Confluence,” the proposed design would widen the left/east top of bank of the channel confluence by 628 feet, and construct a 113-foot-wide 3H:1V benched/terraced vegetated slope. Benching on the slope would be 10 feet wide and occur at 30 and 70 feet from the toe. The proposed widened section of the channel would be soft bottom. Two riprap toedowns would be constructed below the channel bottom and banks. The first riprap toedown would be located at the edge of the proposed widened portion of the channel at a depth and width of 10 feet. The second riprap toedown, which would include bank protection along the base of the proposed left/east bank, would be at a depth of 3 to 10 feet and a width of 20 feet. A 16-foot-wide asphalt concrete maintenance road would be constructed on the proposed left/east top of bank.

Demolition and Excavation – The left/east concrete retaining wall would be demolished. The channel bottom would be excavated to a width of 515 feet; a 3H:1V terraced/benched channel bank would be excavated for an additional 103 feet to meet the existing ground above. Excavation for riprap toedowns would occur at the toe of the proposed left/east bank and at the edge of where the widened and existing concrete channel bottoms would meet, at a depth of 3 to 10 feet.

Compacted Fill and Maintenance Road – The existing ground at the left/east top of bank would be used as the base of the proposed 16-foot-wide asphalt concrete maintenance road. Fencing would be constructed to separate areas of access from the maintenance road, on both the potentially private right-of-way, and the river.

Erosion Control – Erosion control matting, such as TRM would be used to stabilize, prevent channel scour, and to promote vegetation establishment on the left/east channel slope.

Topsoil and Vegetation – Topsoil would aid in the recruitment and establishment of vegetation along the channel’s riparian zone. Topsoil would be placed on the left/east bank after TRM matting is installed. Topsoil areas would be seeded and planted with riparian vegetation per recommendation of the project biologist.

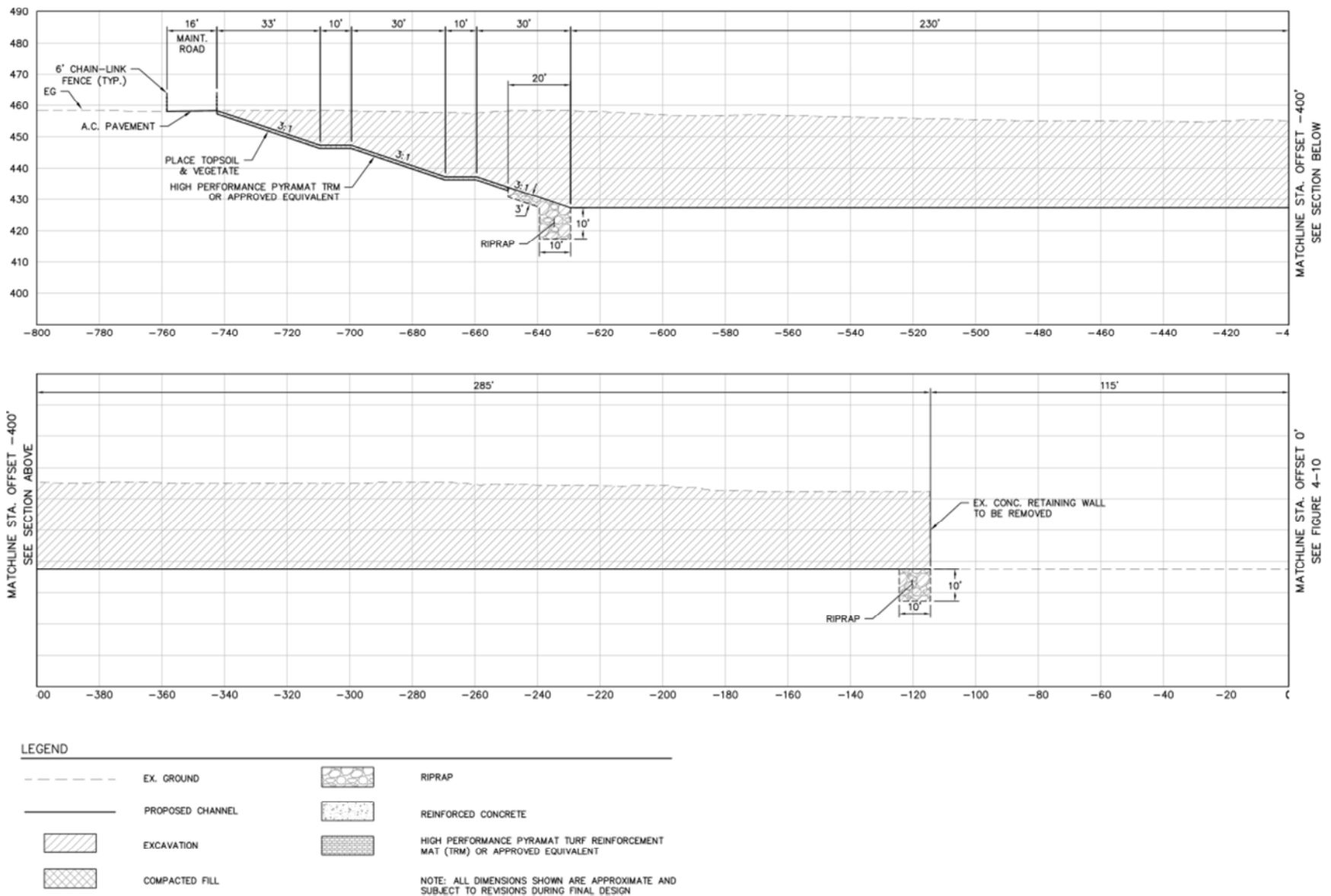
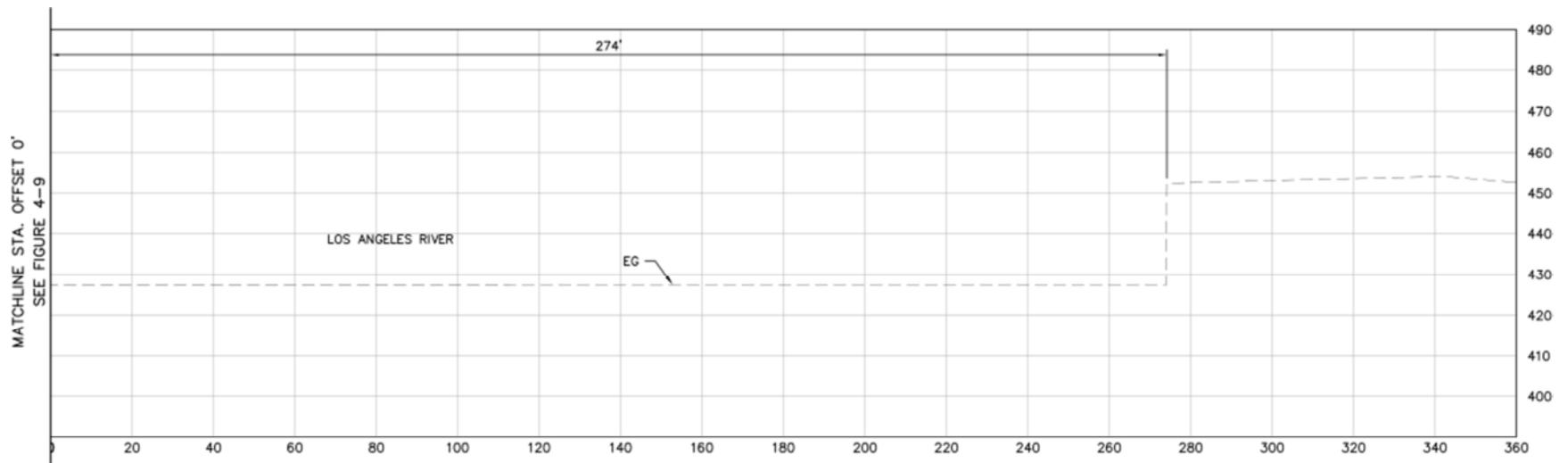

Figure 4.9 Verdugo Wash Cross-Section 3, Upstream of Los Angeles River Confluence



LEGEND





- | | | | |
|---|------------------|---|--|
| --- | EX. GROUND |  | RIPRAP |
| — | PROPOSED CHANNEL |  | REINFORCED CONCRETE |
|  | EXCAVATION |  | HIGH PERFORMANCE PYRAMAT TURF REINFORCEMENT MAT (TRM) OR APPROVED EQUIVALENT |
|  | COMPACTED FILL | | |
- NOTE: ALL DIMENSIONS SHOWN ARE APPROXIMATE AND SUBJECT TO REVISIONS DURING FINAL DESIGN

Figure 4.10 Verdugo Wash Cross-Section 3 (cont'd), Upstream of Los Angeles River Confluence

4.2.8 Cross-Section 4, Sub-Reach 4 - Brazil to Los Feliz Boulevard

Existing Channel Features – The existing trapezoidal channel within the sub-reach varies from grouted rock to concrete paved channel, is 324 feet wide from the top of bank, and 22 feet high from the invert.

Preliminary Channel Design – As seen in Figure 4.11, “Cross-Section 4, Brazil to Los Feliz,” the proposed design would construct four concrete terraced planters in the left/east and right/west banks of the channel. Toedowns with bank protection would be constructed at the toe of the proposed channel banks. A 16-foot-wide asphalt concrete maintenance road would be constructed on both sides of the channel. Grade control structures would be constructed to reduce in-stream velocities and secure natural bed materials for meander and vegetation development.

Demolition and Excavation – Several areas of the reach would undergo demolition and excavation to implement the proposed design. The left/east and right/west banks’ grouted rock or slope paving would be demolished. Excavation of earthen material for four concrete terraced planters at a depth of 4 to 8.75 feet and a width of 12.5 feet would occur on the channel slopes. Excavation would also occur at a depth of 3 to 10 feet at the toe of both banks for proposed toedowns with bank protection. In areas where grade control structures would be implemented, 10 to 15 feet of earthen material would be excavated from the channel bed to accommodate construction of grouted riprap toedowns.

Compacted Fill and Maintenance Road – Compacted fill would be placed behind the right/west and left/east channel top of banks to create 16-foot wide maintenance roads on both sides of the channel. The asphalt concrete maintenance roads would meet the proposed channel’s top of bank on the river and would have a slope of 3H:1V on the landward. Fencing would be constructed to separate areas of access from the maintenance road, on both the potentially private right-of-way, and the river.

Terraced Vegetated Planters – After demolition and excavation, terraced planters would be constructed in the slopes of the existing channel. Planter dimensions would be 4 to 8.75 feet in height and 12.5 feet in width. The terraces would be spaced along the channel wall so that the top of the lowest meets the bottom of the next. The bottom would be flush with the top of the highest point of the grade control structure. Each planter would have a 1-foot-thick concrete bottom and 1.5-foot-thick concrete walls. Concrete baffles would be placed every 20 feet along the terraces to prevent erosion/scour. Terraces would be seeded and planted with native riparian vegetation per the project biologist’s recommendation. The planter boxes would also include drainage holes to help route drainage water from upper boxes to lower boxes.

Topsoil and Vegetation – Topsoil would aid in the recruitment and establishment of vegetation along the channel’s riparian zone. Topsoil would be placed on the slopes of the maintenance road compacted fill and in the concrete terraced planters. Topsoil areas would be seeded and planted with native riparian vegetation per the project biologist’s recommendations.

Grade Control Structure – Grouted riprap grade control structures would be placed every 500 feet along this reach of the channel. Grade control structures would reduce in-stream flow velocities and stabilize the channel's slope and earthen bed material. Grade control structures would be constructed in the channel bottom at a depth of 10 or 15 feet, have a 2H:1V slope on the upstream end and a 4H:1V slope on the downstream end, be 5 feet in width on top, and have a 2-foot-deep and 20-foot-wide low-flow centerline notch.

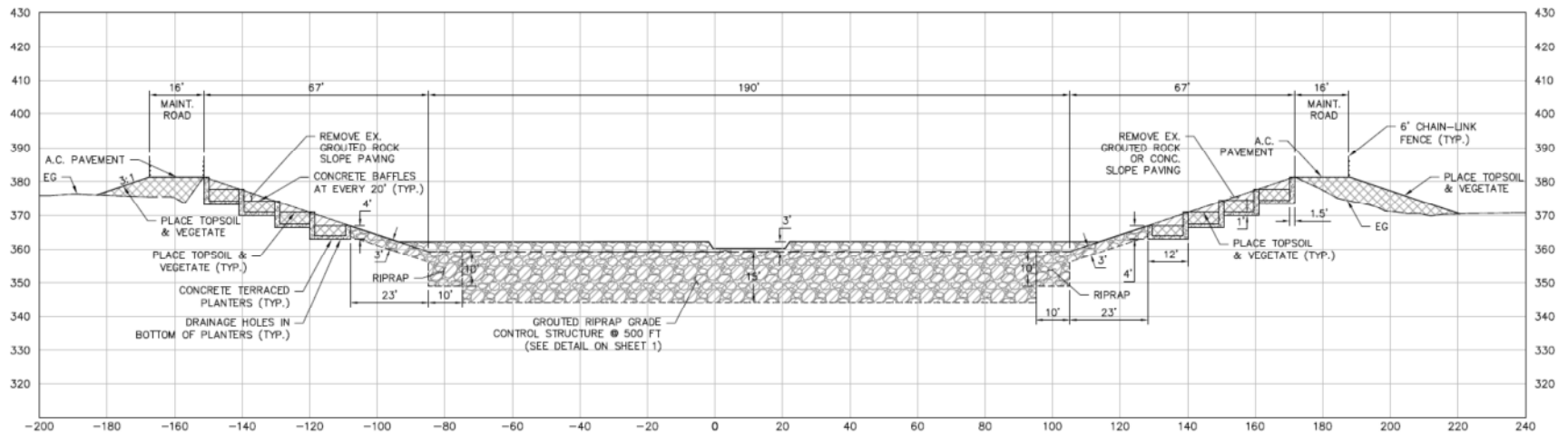

LEGEND

	EX. GROUND		RIPRAP
	PROPOSED CHANNEL		REINFORCED CONCRETE
	EXCAVATION		HIGH PERFORMANCE PYRAMAT TURF REINFORCEMENT MAT (TRM) OR APPROVED EQUIVALENT
	COMPACTED FILL		

NOTE: ALL DIMENSIONS SHOWN ARE APPROXIMATE AND SUBJECT TO REVISIONS DURING FINAL DESIGN.

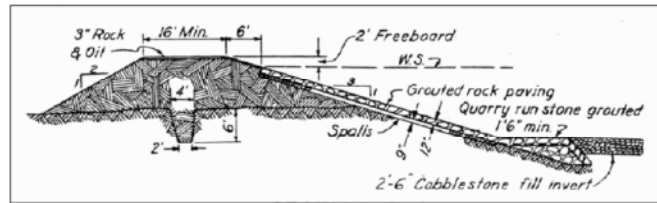

EXISTING TYPICAL SECTION
NTS

Figure 4.11 Cross-Section 4, Brazil to Los Feliz

4.2.9 Cross-Section 5, Sub-Reach 5 - Los Feliz Boulevard to Glendale Freeway

Existing Channel Features – The existing trapezoidal channel within the sub-reach varies from grouted rock to concrete paved channel, is 310 feet wide from the top of bank and 20 feet high from the invert.

Preliminary Channel Design – As seen in Figure 4.12, ” Cross-Section 5, Los Feliz Boulevard to Glendale Freeway,” the proposed design would construct four concrete terraced planters in the left/east bank of the channel slope. The right/west bank of the trapezoidal bank would be replaced by a 22-foot-high vertical retaining wall with subdrainage under the invert slab, which would meet the existing top of bank. Two riprap toedowns would be constructed below the channel bottom and bank. The first riprap toedown would be constructed on the right/west bank and the second that would include bank protection, would be located on the left/east bank. Two 16-foot-wide asphalt concrete maintenance roads would be constructed on the land of the retaining walls on the top of bank. The existing cobble/soft bottom would be protected in place and expanded 27 feet towards the proposed right/west bank of the channel.

Demolition and Excavation – Several areas of the reach would undergo demolition and excavation to implement the proposed design. The left/east and right/west banks’ grouted rock or slope paving would be demolished. Excavation of earthen material for four concrete terraced planters with dimensions of 4 to 8.75 feet deep and 12.5 feet wide would occur along the left/east bank. Excavation on the right/west bank would widen the channel by 60 feet. Toedown excavation would occur at a depth of 3 to 10 feet and 27 and 33 feet wide at the toe of the left/east bank, which would include bank protection at the base of the channel, and right/west bank, respectively. Excavation for the footing of the retaining wall would range from 4 to 12 feet deep and be 13 feet wide. Excavation would also occur behind the location of the proposed retaining wall, and would have a temporary slope of 1.5H:1V to meet the existing ground; excavation would allow temporary access for construction of the walls.

Compacted Fill and Maintenance Road – Compacted fill would be placed behind the left/east and right/west channel top of banks. The compacted fill would be used to create a 16-foot-wide asphalt concrete maintenance road on both sides of the channel, which would meet the proposed channel’s top of bank on the river, and would have a slope of 3H:1V on the landward. Fencing would be constructed to separate areas of access from the maintenance road, on both the potentially private right-of-way, and the river.

Terraced Vegetated Planters – After demolition and excavation, terraced planters would be constructed in the slopes of the existing channel. Planter dimensions would be 4 to 8.75 feet in height and 12.5 feet in width. The terraces would be spaced along the channel wall so that the top of the lowest meets the bottom of the next. The bottom would be flush with the top of the highest point of the grade control structure. Each planter would have a 1-foot-thick concrete bottom and 1.5-foot-thick concrete walls. Concrete baffles would be placed every 20 feet along the terraces to prevent erosion/scour. The planter boxes would also include drainage holes to help route drainage water from upper boxes to lower boxes. Terraces would be seeded and planted with native riparian vegetation per the project biologist’s recommendation.

Topsoil and Vegetation – Topsoil would aid in the recruitment and establishment of vegetation along the channel’s riparian zone. Topsoil would be placed on the slopes of the maintenance road’s compacted fill 3H:1V slopes and in the concrete terraced planters on the left/east bank. Topsoil areas would be seeded and planted with native riparian vegetation per the project biologist’s recommendations.

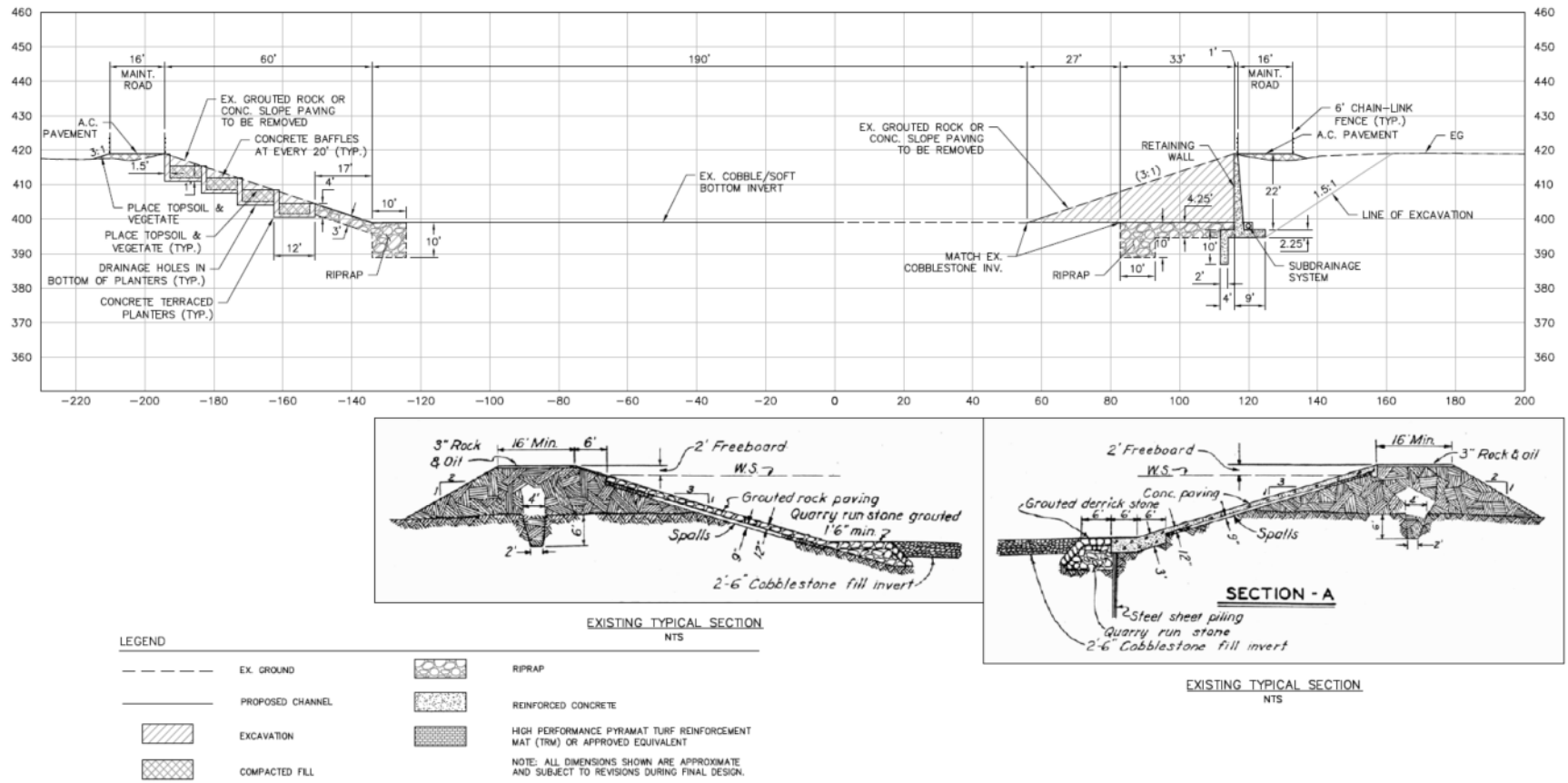

Figure 4.12 Cross-Section 5, Los Feliz Boulevard to Glendale Freeway

4.2.10 Cross-Section 6a, Sub-Reach 6 - Glendale Freeway to Interstate 5

Existing Channel Features – The existing trapezoidal channel within the sub-reach varies from grouted rock to concrete paved, is 365 feet wide from the top of bank, and approximately 22 feet high from the invert.

Preliminary Channel Design – As seen in Figure 4.13, “Cross-Section 6a, Glendale Freeway to Interstate 5,” the proposed design would replace the existing trapezoidal channel’s grouted rock or concrete paved 3H:1V slopes with TRM, topsoil, and vegetation on the left/east bank and right/west bank. Riprap toedowns with bank protection would be placed at the toe of both banks of the channel. Two 16-foot-wide asphalt concrete maintenance roads would be constructed on the channel’s left/east and right/west top of banks. The existing cobble/soft bottom would be protected in place.

Demolition and Excavation – The left/east bank and the right/west bank grouted rock or slope paving would be demolished. Excavation for the left/east bank and the right/west bank toedowns and bank protection would start at the channel toe, and extend 20 feet towards the landward at a depth of 3 to 10 feet below the existing cobble/soft bottom and channel banks.

Compacted Fill and Maintenance Road – Compacted fill would be used to fill behind the left/east and right/west channel top of banks to form the subsurface of the proposed 16-foot-wide maintenance road. Fencing would be constructed to separate areas of access from the maintenance road, on both the potentially private right-of-way, and the river.

Erosion Control – Erosion control matting, such as TRM, would be used to stabilize, prevent channel scour, and to promote vegetation establishment on channel slopes.

Topsoil and Vegetation – Topsoil would aid in the recruitment and establishment of vegetation along the channel’s riparian zone. Topsoil would be placed on the 3H:1V channel slopes after TRM matting has been installed. Topsoil areas would be seeded and planted with native riparian vegetation per the project biologist’s recommendations.

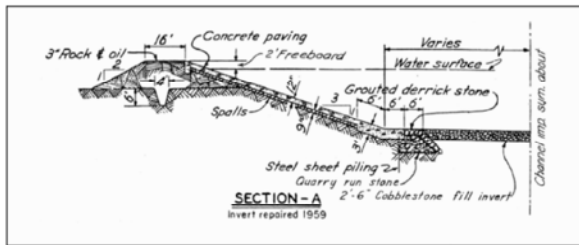
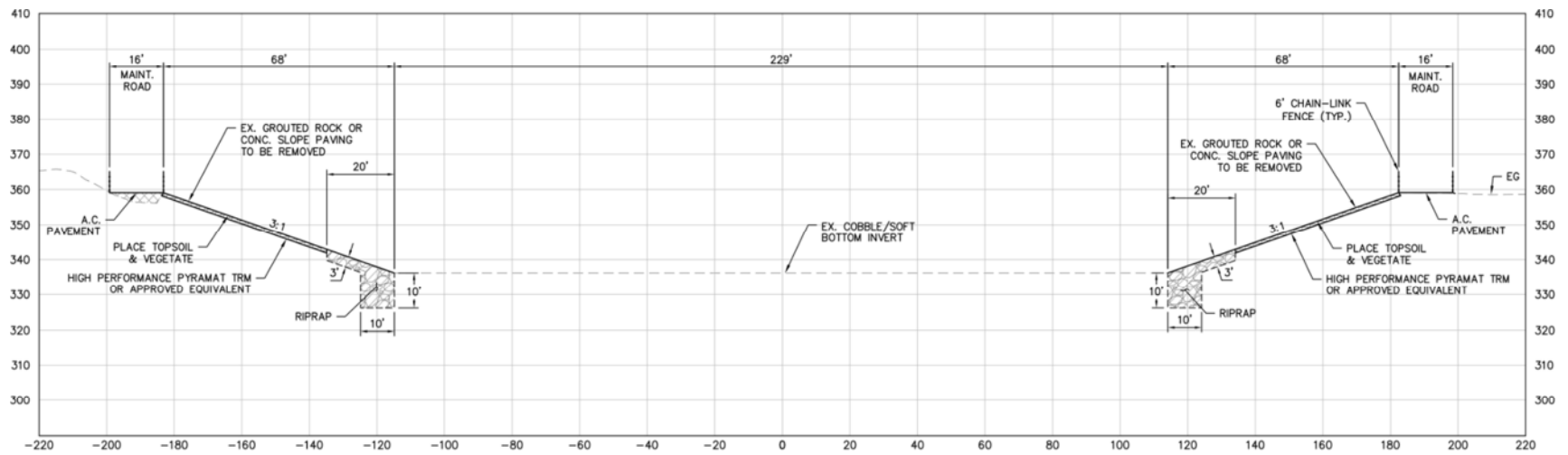

EXISTING TYPICAL SECTION
NTS

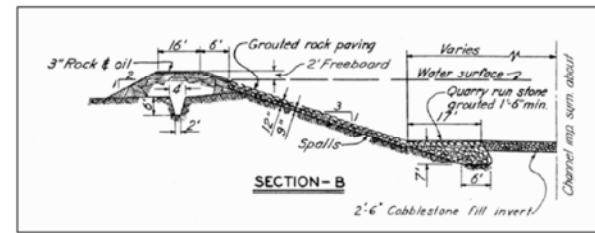

EXISTING TYPICAL SECTION
NTS

LEGEND

	EX. GROUND		RIPRAP
	PROPOSED CHANNEL		REINFORCED CONCRETE
	EXCAVATION		HIGH PERFORMANCE PYRAMAT TURF REINFORCEMENT MAT (TRM) OR APPROVED EQUIVALENT
	COMPACTED FILL		

Figure 4.13 Cross-Section 6a, Glendale Freeway to Interstate 5

4.2.11 Cross-Section 6b, Sub-Reach 6 - Glendale Freeway to Interstate 5

Existing Channel Features – The existing trapezoidal channel within the sub-reach varies from grouted rock to concrete paved channel, is 365 feet wide from the top of bank, and approximately 22 feet high from the invert. The existing channel bottom is cobble/soft bottom.

Preliminary Channel Design – As seen in Figure 4.14, “Cross-Section 6b, Glendale Freeway to Interstate 5,” the proposed design would replace the existing channel’s grouted rock or concrete paved 3H:1V slopes with TRM, topsoil, and vegetation on the left/east bank and the widened right/west bank. The right/west top of bank would be widened by 316 feet to provide room for the construction of wetlands. Three riprap toedowns with slope protection would be constructed: one at the toe of the left/east bank, one at the toe of the proposed wetlands (existing right/west bank), and the third at the toe of the widened right/west bank. Maintenance roads would be constructed on both sides of the channel’s top of banks. The existing cobble/soft bottom would be protected in place.

Demolition and Excavation – The right/west bank and left/east bank grouted rock or slope paving would be demolished. Demolition would also occur as needed to widen the right/west top of bank by 316 feet. The existing right/west bank would be excavated to an elevation of 6 feet above the invert and a width of 316 feet. The new right/west bank would be excavated at a 3H:1V slope and meet the existing ground at the top of bank. Excavation for the right/west bank, the left/east bank, and the wetland toedown would start at the existing channel toe and extend 20 feet towards the landward, at a depth of 3 to 10 feet below the existing cobble/soft bottom and channel banks.

Compacted Fill and Maintenance Road – Two 16-foot-wide asphalt concrete maintenance roads would be constructed on the left/east and right/west channel top of banks. Compacted fill would be used to fill behind the left/east channel top of bank to form the subsurface for the road. Fencing would be constructed to separate areas of access from the maintenance road, on both the potentially private right-of-way, and the river.

Wetlands – The construction of wetlands would start 20 feet landward from the existing channel right/west bank toe, terraced to an elevation of 6 feet above the invert. The wetlands would extend for a distance of 300 feet to the proposed right/west bank toe. The 6-foot-high terraced wetland area would spread higher channel flows, assist in treating pollutants, and create riverine wetland habitat.

Erosion Control – Erosion control matting, such as TRM, would be used to stabilize, prevent channel scour, and to promote vegetation establishment on channel slopes.

Topsoil and Vegetation – Topsoil would aid in the recruitment and establishment of vegetation along the channel’s riparian zone. Topsoil would be placed on the right/west bank and the left/east bank’s 3H:1V channel slopes after TRM matting is installed. Topsoil would also be placed in the proposed wetlands area. Topsoil areas would be seeded and planted with native riparian vegetation per the project biologist’s recommendations.

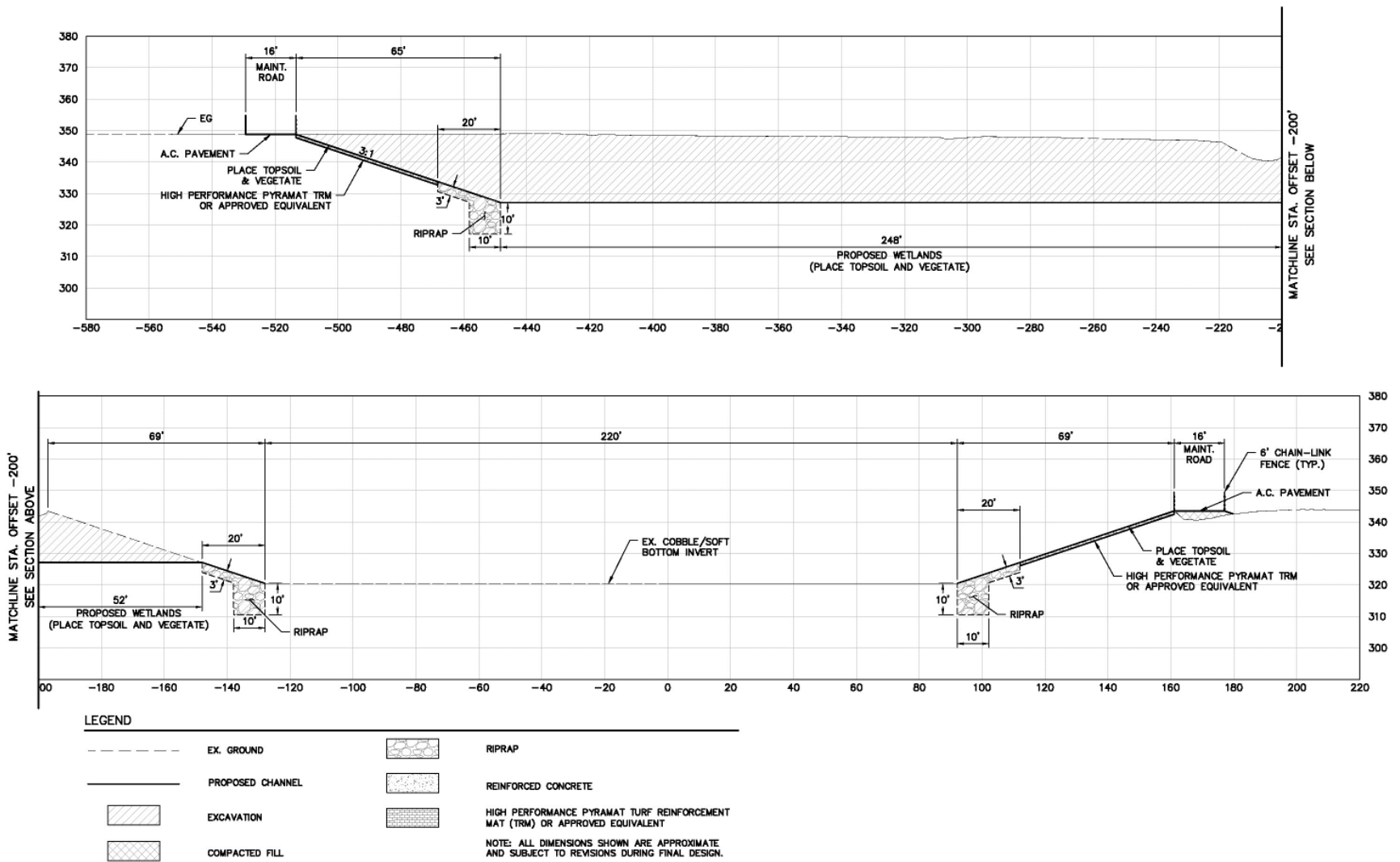

Figure 4.14 Cross-Section 6b, Glendale Freeway to Interstate 5

4.2.12 Cross-Section 6c, Sub-Reach 6 - Glendale Freeway to Interstate 5

Existing Channel Features – The existing trapezoidal channel within the sub-reach varies from grouted rock to concrete paved channel, is 380 feet wide from the top of bank and approximately 26 feet high from the invert. The existing channel bottom is cobble/soft bottom.

Preliminary Channel Design – As seen in Figure 4.15, “Cross-Section 6c, Glendale Freeway to Interstate 5,” the proposed design would replace the existing trapezoidal channel’s grouted rock or concrete paved 3H:1V slopes with erosion control matting and vegetation on the left/east bank and right/west bank. Riprap toedowns with bank protection would be placed at the toe of both banks in the channel, and extend 20 feet landward. Asphalt concrete maintenance roads would be constructed on both sides of the channel at the top of bank. The existing cobble/soft bottom would be protected in place.

Demolition and Excavation – The left/east bank and right/west bank grouted rock or slope paving would be demolished. Excavation for the left/east bank and the right/west bank toedowns would start at the channel toe and extend 20 feet landward, at a depth of 10 to 3 feet below the existing cobble/soft bottom and the channel banks.

Compacted Fill and Maintenance Road – Compacted fill would be used to fill behind the left/east and right/west channel top of banks to form the subsurface of the proposed 16-foot-wide maintenance roads. The fill would meet the top of bank on the river, and have a slope of 3H:1V to meet the existing ground. Fencing would be constructed to separate areas of access from the maintenance road, on both the potentially private right-of-way, and the river.

Erosion Control – Erosion control matting, such as TRM, would be used to stabilize, prevent channel scour, and to promote vegetation establishment on the channel’s 3H:1V slopes.

Topsoil and Vegetation – Topsoil would aid in the recruitment and establishment of vegetation along the channel’s riparian zone. Topsoil would be placed on the left/east and right/west banks’ 3H:1V channel slopes after TRM matting is installed. Topsoil without TRM matting would be placed on the 3H:1V maintenance road slopes. Topsoil areas would be seeded and planted with vegetation per the project biologist’s recommendations.

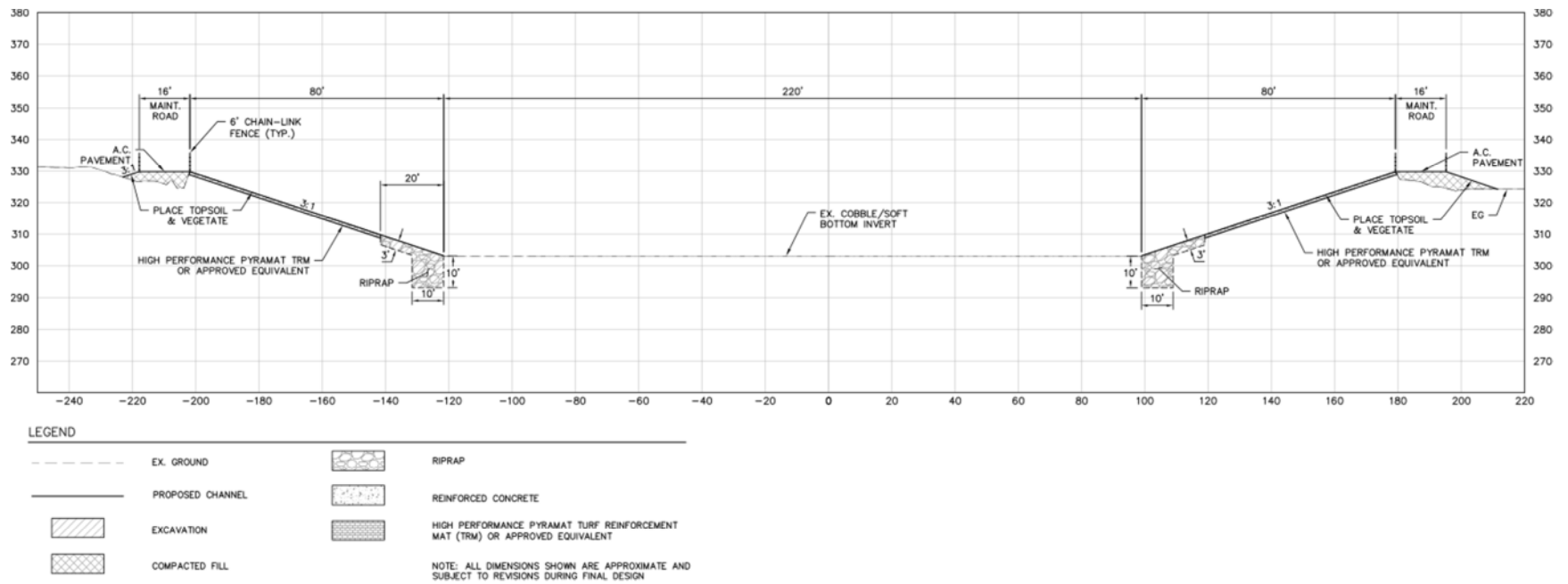

Figure 4.15 Cross-Section 6c, Glendale Freeway to Interstate 5

4.2.13 Cross-Section 7, Sub-Reach 7 - Interstate 5 to Main

Existing Channel Features – The existing trapezoidal reinforced concrete channel with concrete bottom is 264 feet wide from the top of bank and approximately 26 feet high from the invert.

Preliminary Channel Design – As seen in Figure 4.16, “Cross-Section 7, Interstate 5 to Main Street,” the proposed design would widen the bottom of the channel by 52 feet and construct a 29-foot-high retaining wall with subdrainage below the invert slab, on the left/east and right/west banks. Reinforced cantilevered platforms would be constructed on the top of the proposed retaining walls and would extend 25 feet over the channel. Reinforced concrete piers would be located on the in-channel edge of the platform and spaced 25 feet apart for support. A concrete reinforced naturalized channel would be constructed on the left/east and right/west banks at the footings of the platforms and extend 50 feet towards the center of the channel. A 16-foot-wide asphalt concrete maintenance road would be constructed on the retaining wall land on the top of both banks. After construction of design features, the remaining low-flow channel and concrete-lined bottom would be protected in place.

Demolition and Excavation – Several areas of the reach would undergo demolition and excavation to implement the proposed design. The left/east and right/west banks’ existing concrete slope protection would be demolished. A 31-foot stretch of reinforced concrete channel bottom starting at the existing toe and extending towards the channel centerline would be demolished. Excavation would widen the channel bottom by 52 feet on both banks, changing the channel morphology from trapezoidal to vertical. Retaining wall and pier footing locations at depths of 4.25 to 10 feet and a width of 42 feet would be excavated. Naturalized channel locations would be excavated at a depth of 12 feet and width of 50 feet towards the channel centerline. Excavation would occur behind the locations of the proposed retaining walls and would have a temporary slope of 1.5H:1V to meet the existing ground; excavation would allow temporary access for construction of the retaining walls.

Compacted Fill and Maintenance Road – After construction of the retaining walls, compacted fill would be placed behind the left/east and right/west channels’ retaining walls. The fill would be placed to accommodate a 16-foot-wide paved asphalt-concrete maintenance road on both banks. The river of the maintenance roads would meet the top of the proposed retaining walls on both banks. The land compacted fill on the left/east bank maintenance road would be sloped 3H:1V to meet the existing ground. Fencing would be constructed to separate areas of access from the maintenance road and the platform, on both the potentially private right-of-way, and the river.

Planter Boxes (Naturalized Channel) – Naturalized channel would be constructed at the edge of the retaining wall toedowns and would extend 50 feet towards the center of the channel at a depth of 12 feet. The surface of the naturalized channel would be flush to the invert. The bottom 6 feet of the channel would be filled with riprap and the top 6 feet with soil. The soil would be secured with concrete baffles spaced 20 feet apart to prevent scour/erosion. The planter boxes would also include drainage holes to help route drainage water from upper boxes to lower boxes. Naturalized channel would be seeded and planted with native riparian vegetation per the project biologist’s recommendation.

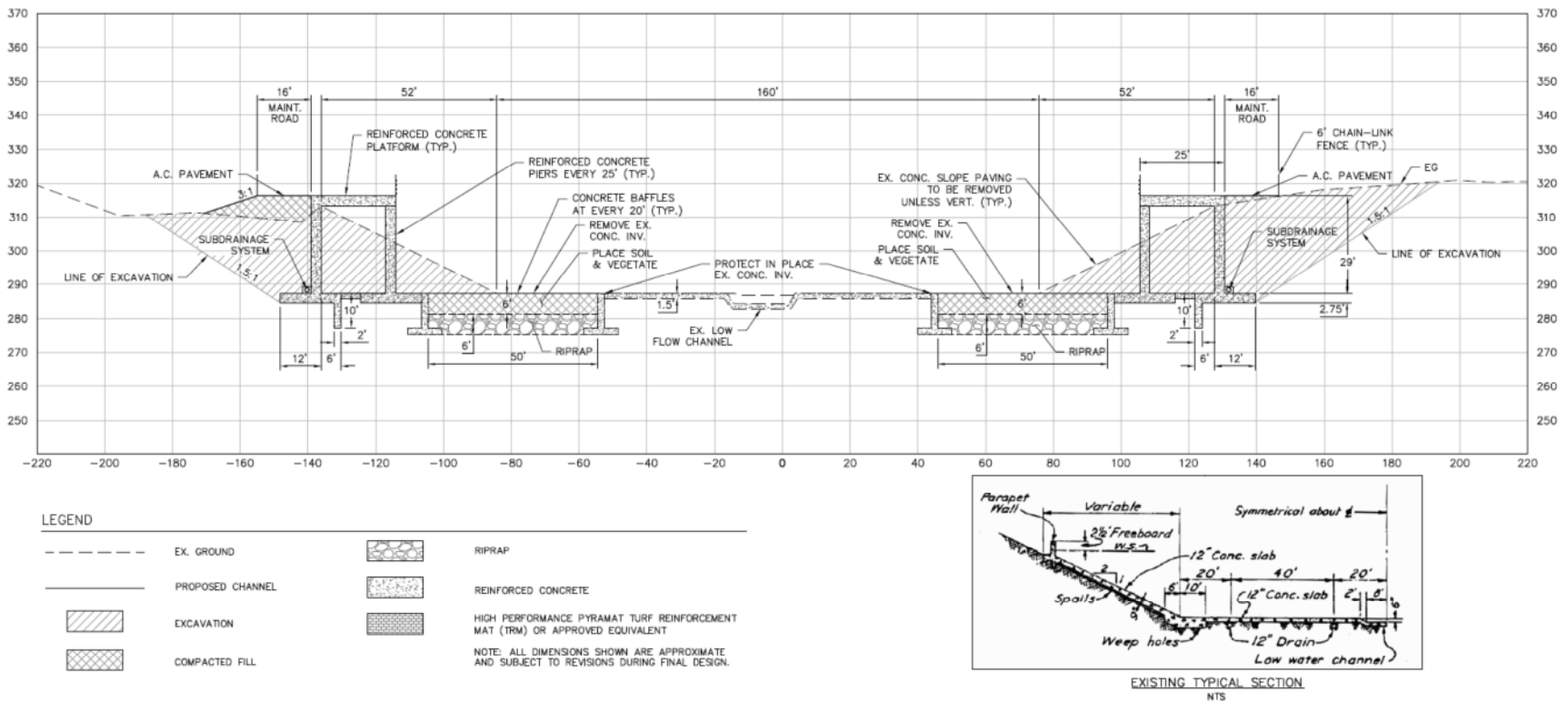

Figure 4.16 Cross-Section 7, Interstate 6 to Main Street

4.2.14 Arroyo Seco Cross-Section, Sub-Reach 7 – Arroyo Seco Confluence

Existing Channel Features – The existing rectangular reinforced concrete channel with concrete bottom is 66 feet wide from the top of bank and approximately 24 feet high from the invert.

Preliminary Channel Design – As seen in Figure 4.17, “Arroyo Seco Cross-Section,” the proposed design would remove 4 feet and 24 feet off the top of the existing left/south and right/north retaining walls respectively. The channel bottom would be widened by 10 feet on both banks. Both sides of the channel would be additionally widened to accommodate 3H:1V vegetated banks; the left/south bank would be widened by 60 feet, 12 feet above the invert, and the right/north bank widened by 62 feet, 6 feet above the invert. The existing concrete bottom would be protected in place. An asphalt concrete maintenance road would be constructed on both sides of the channel top of bank. Fencing would be constructed to separate areas of access from the maintenance road, on both the potentially private right-of-way, and the river.

Demolition and Excavation – Demolition of the tops of the retaining walls would occur on both sides of the channel; the top 4 feet of the left/south retaining wall and the top 24 feet of the right/north retaining wall would be demolished. From the new height of the retaining walls, both sides of the channel would be excavated and benched 10 feet landward; trapezoidal banks with a slope of 3H:1V would be excavated and extend from the benches for 60 feet on the left/south bank and 62 feet on the right/north bank. In addition, the left/south bank would be excavated and leveled for the construction of a 16-foot-wide asphalt concrete maintenance road.





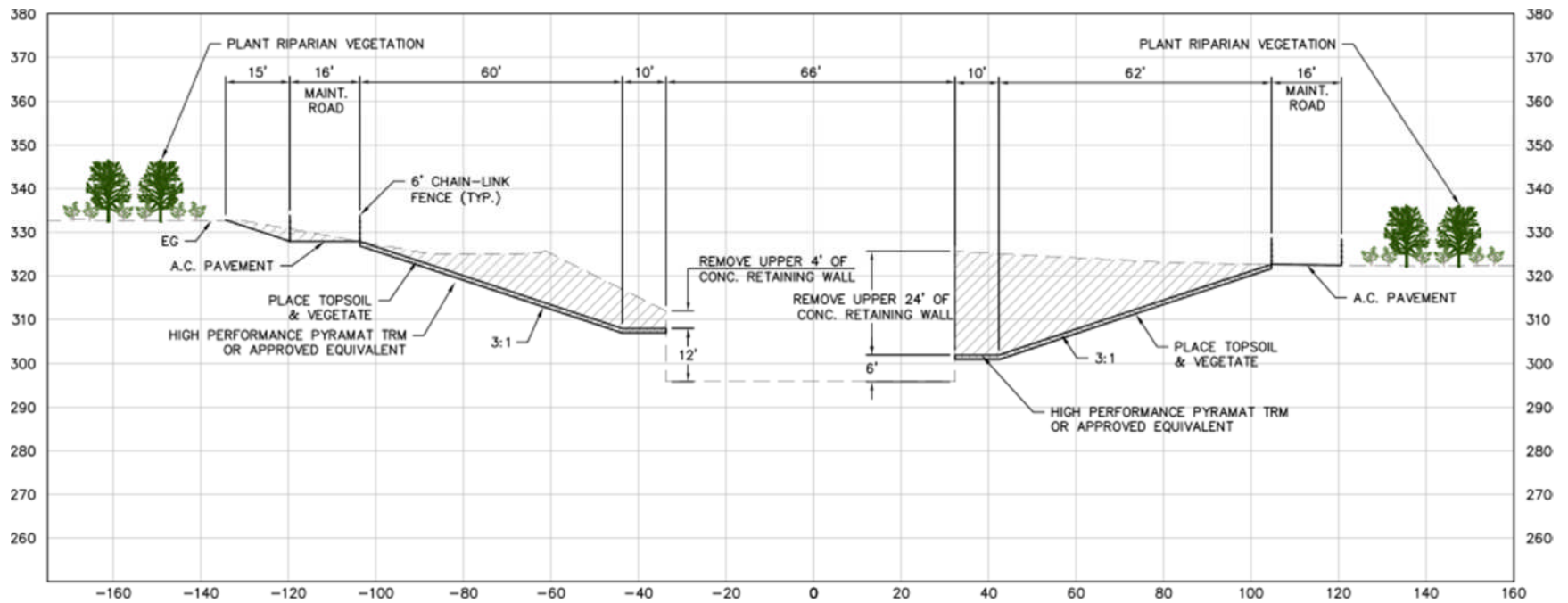

Maintenance Road – The proposed channel design would construct two 16-foot-wide asphalt concrete maintenance roads on the left/south and the right/north banks of the channel. Fencing would be constructed to separate areas of access from the maintenance road, on both the potentially private right-of-way, and the river.

Erosion Control – Erosion control matting, such as TRM, or approved equivalent, would be used to stabilize, prevent channel scour, and to promote vegetation establishment on channel’s 3H:1V slopes.

Topsoil and Vegetation – Topsoil would aid in the recruitment and establishment of vegetation along the channel’s riparian zone. Topsoil would be placed on the left/south and right/north banks’ 3H:1V channel slopes, after TRM matting is installed. Topsoil areas would be seeded and planted with native riparian vegetation per the project biologist’s recommendations.



LEGEND

	EX. GROUND		RIPRAP
	PROPOSED CHANNEL		REINFORCED CONCRETE
	EXCAVATION		HIGH PERFORMANCE PYRAMAT TURF REINFORCEMENT MAT (TRM) OR APPROVED EQUIVALENT
	COMPACTED FILL		

NOTE: ALL DIMENSIONS SHOWN ARE APPROXIMATE AND SUBJECT TO REVISIONS DURING FINAL DESIGN

Figure 4.17 Arroyo Seco Cross-Section

4.2.15 Cornfields Cross-Section, Sub-Reach 7, Cornfields Hydrologic Connection

Existing Channel Features – The preliminary design is proposing to hydrologically connect the upstream portion of the Cornfields site with the Los Angeles River; currently, there is no existing channel at the site.

Preliminary Channel Design – As seen in Figure 4.18, “Cornfields Cross-Section,” the proposed design would create a 379-foot-wide channel with a 51-foot-wide low-flow channel near center. The left/north and right/south banks of the channel would have 3H:1V slopes with a benched point on either bank. The channel bottom and slopes would be covered with an impermeable liner and vegetated. An asphalt concrete maintenance road would be constructed on both sides of the channel top of bank. A 6-foot chain link fence would be constructed on both shoulders of the maintenance road to seclude trespassers from the road and the channel.

Demolition and Excavation – No major demolition would occur in the proposed channel area. Excavation in the main channel would occur at an average depth of 7 to 8 feet and a width of 325 feet. Within the main channel, excavation of the 51-foot-wide proposed low-flow channel would occur at a depth of 14 feet and width of 15 feet, with 18-foot-wide 3H:1V slopes on either. Excavation of the left/north bank would be 25 feet wide and right/south bank 29 feet wide; approximately halfway up the banks 3H:1V slopes, a 10-foot-wide terraced/benched area would be excavated.

Maintenance Road – The proposed channel design would construct two 16-foot-wide asphalt concrete maintenance roads on the right/south and the left/north banks of the channel. Fencing would be constructed to separate areas of access from the maintenance road, on both the potentially private right-of-way, and the river.

Impermeable Liner and Vegetation – Depending on the level of residual contamination of the soil, an impermeable liner would be used to cover the surface of the channel bottom and slopes. The impermeable liner would prevent the interaction between surface and groundwater and the potential for contamination. Impermeable liners would be seeded and planted with native riparian vegetation and wetland vegetation per the project biologist’s recommendations. (Costs for the liner have been included in the subsequent cost estimate.)

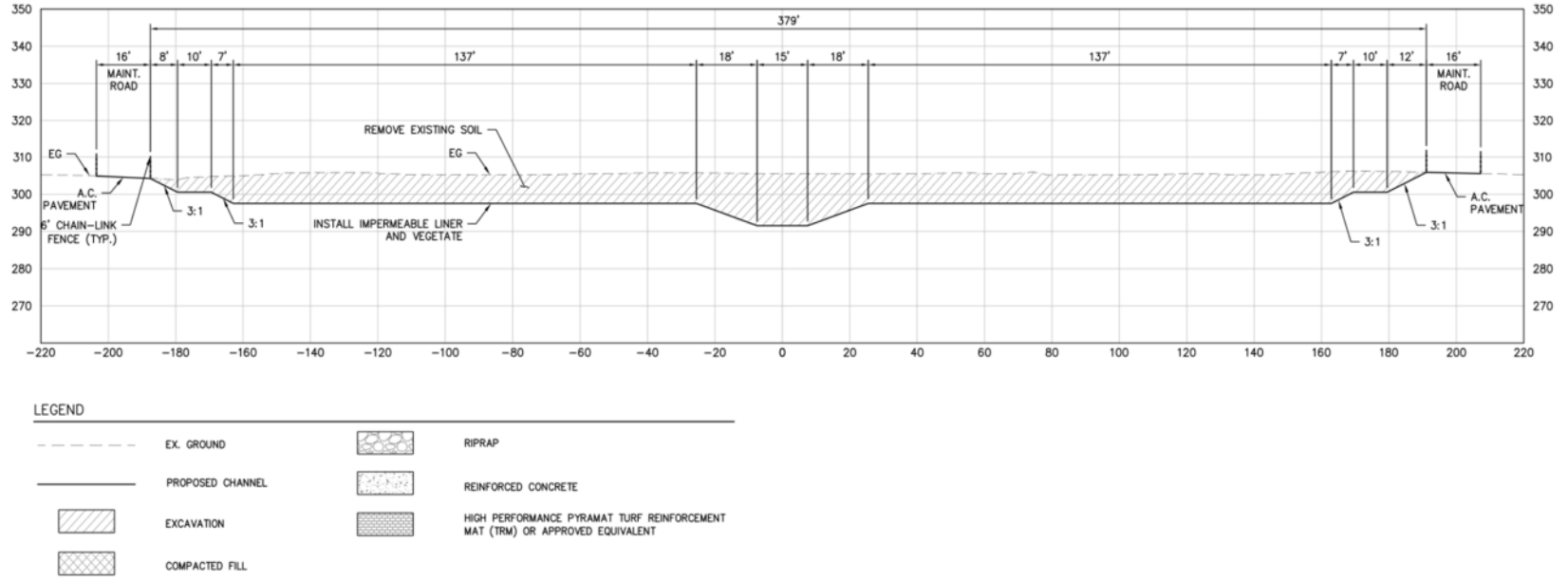

Figure 4.18 Cornfields Cross-Section

4.2.16 Cross-Section 8a, Sub-Reach 8 - Main to First

Existing Channel Features – The existing trapezoidal reinforced concrete channel is 237 feet wide from the top of bank and approximately 22 feet high from the invert. The existing channel bottom is cobble/soft bottom.

Preliminary Channel Design – As seen in Figure 4.19, “Cross-Section 8a, Main to First Street,” the proposed design would widen the left/east top of bank by 298 feet to provide room for the construction of a wetland area. Due to the widening of the left/east bank and channel bottom, the existing railroad would be impacted; the railroad would need to be elevated on a trestle above the proposed wetland area. Construction of the trestle would avoid realignment of the current railway and would provide hydrologic connection and flow through supportive of wetland habitat proposed on the west and east of the railway line. The existing channel’s right/west bank concrete paved 3H:1V slopes would be replaced with riprap bank protection at the base of the bank and vegetated erosion control matting for the remaining upper portion of the bank. Riprap toedowns with bank protection would be constructed at the toe of the left/east and right/west banks and at the channel’s transition to wetland. Maintenance roads would be constructed on both sides of the channel’s top of banks. The existing concrete channel bottom would be replaced by soft “natural” substrate. Grade control structures would be constructed to reduce in-stream velocities and secure natural bed materials for meander and vegetation development.

Demolition and Excavation – The right/west bank and left/east bank slope paving would be demolished. Demolition would also occur as needed to widen the left/east top of bank by 190 feet. The existing left/east bank would be excavated to a height of 2 feet above the existing invert for 190 feet landward. At 190 feet, the toe of the new right/west bank would begin with a 3H:1V slope to the top of bank and existing ground. Excavation on the right/west top of bank would be conducted to shape and level the area for the proposed maintenance road. Riprap toedowns with bank protection at the channel toes would be excavated to a depth of 3 to 10 feet below the channel bottom and banks, and a width of 20 feet on the left/east bank to 30 feet on the right/west bank. Excavation on the east of the grade control structure at a depth of 10 feet and width of 10 feet would be used for a grade control structure toedown.

Compacted Fill and Maintenance Road – A 16-foot-wide asphalt concrete maintenance road is proposed to be constructed on the left/east and right/west channel top of bank. Fencing would be constructed to separate areas of access from the maintenance road, on both the potentially private right-of-way, and the river.

Wetlands – The construction of wetlands would start on the eastern edge and top of the proposed grade control structure, 2 feet above the invert. The wetlands would extend for a distance of 190 feet landward to the proposed left/east bank toedown. The wetland area would spread higher channel flows, assist in treating pollutants, and create riverine wetland habitat for wildlife and aesthetics.

Erosion Control – Erosion control matting, such as TRM, would be used to stabilize, prevent channel scour, and to promote vegetation establishment on channel slopes above the proposed riprap toedown bank protection structures.

Topsoil and Vegetation – Topsoil would aid in the recruitment and establishment of vegetation along the channel's riparian zone. Topsoil would be placed on the left/east bank and the right/west bank 3H:1V channel slopes after TRM matting is installed. Topsoil without TRM matting would be placed in the wetlands area. Topsoil areas would be seeded and planted with native riparian vegetation and wetland vegetation per the project biologist's recommendations.

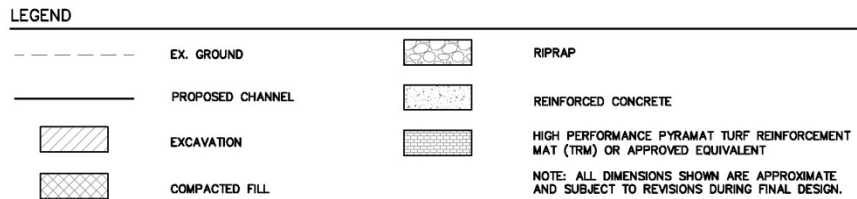
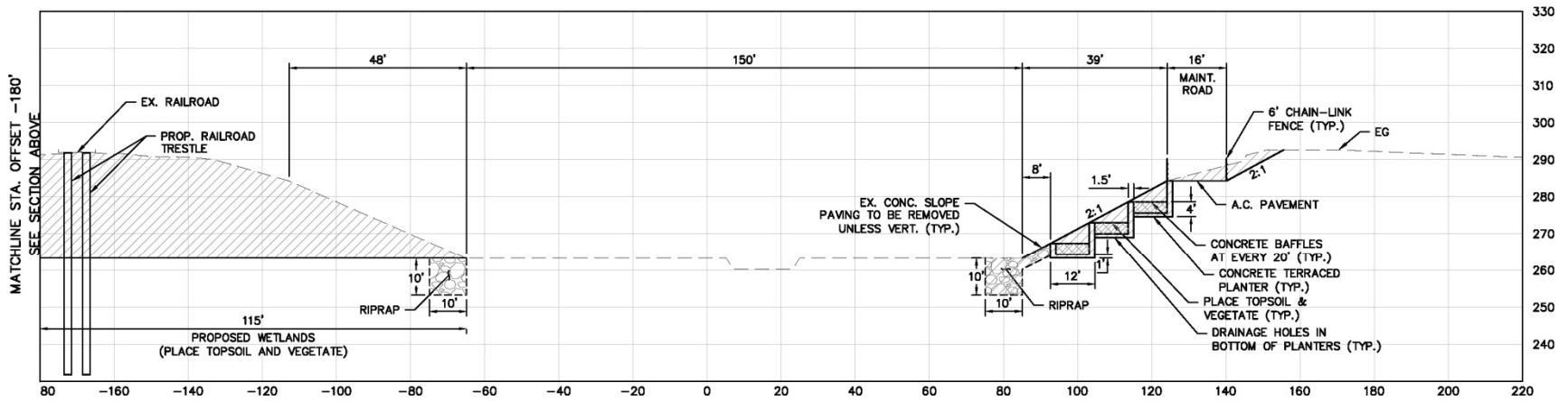
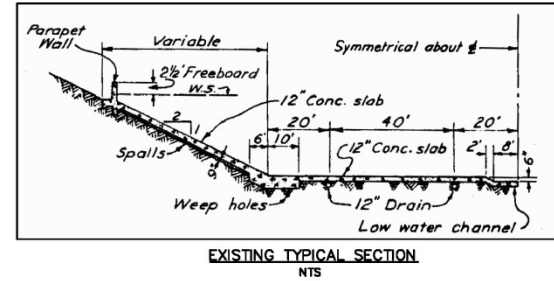
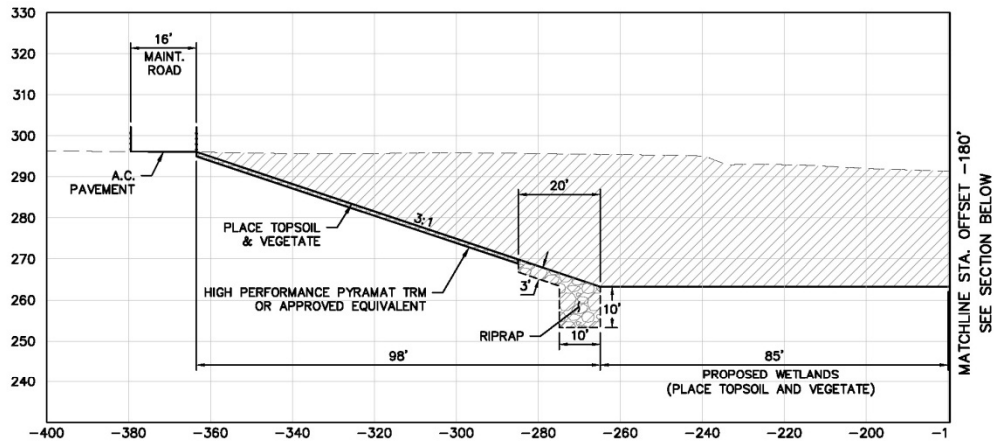

Figure 4.19 Cross-Section 8a, Main to First Street

4.2.17 Cross-Section 8b, Sub-Reach 8 - Main to First

Existing Channel Features – The existing trapezoidal channel within the sub-reach varies from grouted rock to concrete paved channel, is 264 feet wide from the top of bank, and 26 feet high from the invert.

Preliminary Channel Design – As seen in Figure 4.20, “Cross-Section 8b, Main to First Street,” the proposed design would construct four concrete terraced planters in the 3H:1V left/east bank. The right/west channel bottom would be widened by 52 feet; a 29-foot-high retaining wall with subdrain system under the invert slab would be constructed at the new toe. Reinforced platforms would be constructed on the top of the proposed retaining wall and would extend 25 feet over the channel. Reinforced concrete piers located on the in-channel edge of the platforms would be spaced 25 feet apart for platform support. Two concrete reinforced sections of naturalized channel would be constructed in the channel bottom on the left/east and right/west banks of the channel. A riprap toedown with bank protection would be constructed at the toe of the left/east bank. A 16-foot-wide asphalt concrete maintenance road would be constructed on both sides of the channel’s top of bank. After construction of project features, the remaining existing low-flow channel and concrete bottom would be protected in place.

Demolition and Excavation – Several areas of the reach would undergo demolition and excavation to implement the proposed design. The left/east and right/west bank slope paving and approximately 100 feet of the channel bottom would be demolished. Excavation of earthen material for four concrete terraced planters at a depth of 4 to 8.75 feet and a width of 12.5 feet would occur in the channel’s left/east bank slope. Excavation on the right/west bank would widen the channel bottom by 52 feet, changing the channel morphology from trapezoidal to vertical. Excavation to construct retaining wall and pier footings would be at a depth of 2.75 to 10 feet and a width of 42 feet. Excavation to construct naturalized channel at the edge of right/west bank pier support footings and the left/east bank toedown would be 12 feet deep and extend 50 feet towards the channel centerline. Excavation would also occur behind the proposed retaining wall, and would have a temporary slope of 1.5H:1V to meet the existing ground; excavation would allow temporary access for construction of the retaining wall.

Maintenance Road – The asphalt concrete maintenance roads would meet the proposed channel’s top of bank on the river and would have a slope of 3H:1V on the landward. Fencing would be constructed to separate areas of access from the maintenance road, on both the potentially private right-of-way, and the river.

Terraced Vegetated Planters – After demolition and excavation, terraced planters would be constructed in the slopes of the existing channel. Planter dimensions would be 4 to 8.75 feet in height and 12.5 feet in width. The terraces would be spaced along the channel wall so that the top of the lowest meets the bottom of the next. The bottom would be flush with the top of the highest point of the grade control structure. Each planter would have a 1-foot-thick concrete bottom and 1.5-foot-thick concrete walls. Concrete baffles would be placed every 20 feet along the terraces to prevent erosion/scour. Terraces would be seeded and planted with native riparian vegetation per the project biologist’s recommendation.

Planter Boxes (Naturalized Channel) – Naturalized channel would be constructed at the edge of the retaining wall toedown on the right/west bank and on the left/east bank, extending 50 feet into the center of the channel at a depth of 12 feet. The surface of the channel would be flush to the invert. The bottom 6 feet of the channel would be filled with riprap, and the top 6 feet with soil. The soil would be secured with concrete baffles spaced 20 feet apart to prevent scour/erosion. The boxes would also include drainage holes to help route drainage water from upper boxes to lower boxes.

Topsoil and Vegetation – Topsoil would aid in the recruitment and establishment of vegetation along the channel’s riparian zone and bottom. Topsoil would be placed in the concrete terraced planters and the naturalized channel. Topsoil areas would be seeded and planted with native wetland/riparian vegetation per the project biologist’s recommendations.

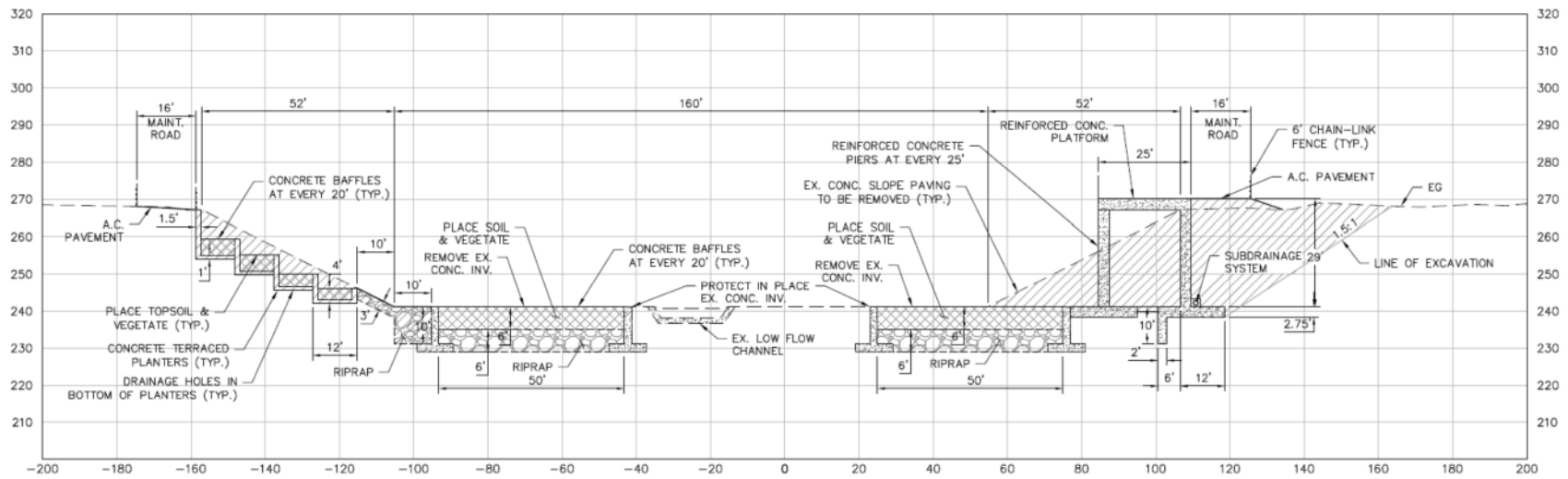

LEGEND

---	EX. GROUND		RIPRAP
---	PROPOSED CHANNEL		REINFORCED CONCRETE
	EXCAVATION		HIGH PERFORMANCE PYRAMAT TURF REINFORCEMENT MAT (TRM) OR APPROVED EQUIVALENT
	COMPACTED FILL		

NOTE: ALL DIMENSIONS SHOWN ARE APPROXIMATE AND SUBJECT TO REVISIONS DURING FINAL DESIGN.

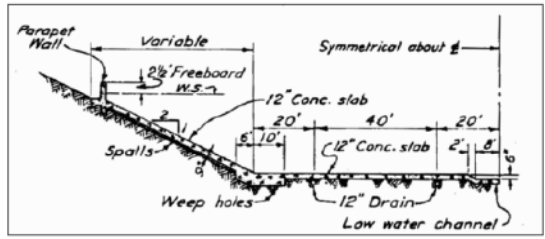

EXISTING TYPICAL SECTION
NTS

Figure 4.20 Cross-Section 8b, Main to First Street

5. UTILITIES

A desktop survey of utilities within the ARBOR reach was conducted from the Headworks facility to 1st Street. The “Los Angeles River Utility Report” (Attachment 2) details the utility survey methodology and findings, which includes associated tables and maps. Utility locations were identified based on information received from utility owners.

A preliminary assessment of the utilities within the tentatively selected plan (TSP) and the sub-measures for the study area have identified Reach 6 and 7 as having potential relocations. In Reach 6 there are 8 high voltage transmission line towers within the study area where the TSP has identified widening of the channel, creation of marsh lands and planting of riparian habitat. In order to accomplish the sub-measures they will need to grade areas to a lower elevation and terrace banks. In Reach 6, we have identified 8 utility towers that may need to be relocated. However, Alternative 13 channel widening in Reach 6 is confined to G-2 (Taylor Yard) and it is possible that no more than 6 towers will need to be moved. No banks are terraced in Alternative 13, Reach 6, except in G1 (Bowtie), which allows for design around the towers. Terracing stays within the bounds of the existing trapezoidal area of the channel wall and transitions to the widened area in G2. Final determination will be reached during design in coordination with the utility owners.

In Reach 7, 15 transmission line towers have been identified as potential utility relocations. In this reach, according to the TSP, the concrete walls will be reshaped to accommodate vegetation or planting boxes. Current plans to accomplish this sub-measure involve lowering the channel banks and terrace them. Current analysis does not show a need to provide set back levees or berms. The current plan is to remain within the current configuration of the channel and the only real physical changes will be in the channel and banks of the Arroyo Seco. This would most likely have an impact on just 10 of the utility towers since we are remaining in the channel and restoration features on the fringes of restoration can be worked around.

According to the Real Estate Appendix, a preliminary real estate assessment following the guidelines set forth in Real Estate Policy Guidance Letter No. 31 was completed for the transmission tower in Reach 6 and 7 of the TSP. Based on the real estate assessment, the transmission towers are of the type eligible for compensation and Los Angeles Department of Water and Power (LADWP) has been identified with a compensable interest in the property in the cases where the LADWP has been identified as the fee owner of the right of way. At this time only 3 of the 23 transmission towers that have been identified on land owned in fee by LADWP. Further real estate analysis will need to be completed to determine whether LADWP has a compensable interest in the property where the other 20 transmission towers are located. If LADWP is determined to have a compensable interest in the property the cost to relocate the identified utilities should be captured as a LERRD cost and not construction.

Additional information will need to be collected in coordination with utility owners during design and pre-construction surveys. Identification of elevations, pipe diameters, connection points, materials, and other details may require potholing or other field investigations if not readily available from the utility owners prior to a comprehensive survey. Cost estimates have been included for all 23 utility towers.

6. FINAL ARRAY OF ALTERNATIVES

Four alternatives were selected for further analysis. These include: 10-ARBOR Riparian Transitions, 13-ARBOR Corridor Extension, 16-ARBOR Narrows to Downtown, and 20-ARBOR Riparian Integration via Varied Ecological Reintroduction. These are also referred to by the following acronyms:

- Alternative 10-ART
- Alternative 13-ACE
- Alternative 16-AND
- Alternative 20-RIVER

The final array of four alternatives was developed by combining separate, independent sub-reaches from the preliminary 19 alternatives that optimized habitat benefits compared to costs. Table 6.1, below, includes an overview of each. The right hand column indicates which reaches from the preliminary 19 alternatives make up each of the final four alternatives. So, for example, Alternative 10-ART represents the design configuration of Reaches 1 and 2 from Preliminary Alternative 11, the design configuration of Reach 3 from Alternative 17, the design configuration of Reaches 4 and 5 from Alternative 16, and so on.

Formulation and analysis of the alternatives is described in the main report and not repeated herein.

6.1 Maps and Revised Cross-Sections

Mapping and revised cross-sections are provided in Attachments 3 and 4 in order to depict the final array of alternatives. Mapping includes the aerial extent of each project feature with the study area displayed on four 11"x17" maps from upstream to downstream.

The preliminary set of typical cross-sections was developed to aid in development of quantities and costs and, therefore, include more features than are included in the final array. Consequently, several modified cross-sections included in Attachment 4 depict only the structural measures that make up the final array. All are subject to additional modifications based on further analysis that could change the dimensions of foundations and retaining walls, for example, during detailed design. Typical cross-sections focus on the main river channel and do not generally include features beyond the main channel such as riparian corridors or channels.

Table 6.1 Final Array of Alternatives Summarized

Name	Description	Reaches (R) & Alternatives (A)
<p align="center">10 ARBOR Riparian Transitions (ART)</p>	<p>Focuses on areas upstream and downstream of existing soft-bottomed Glendale Narrows; includes all sub-reaches but limited restoration in sub-reaches 3, 4 and 5.</p>	<p>R1A11 R2A11 R3A17 R4 A16 R5A16 R6A14 R7A09 R8A15</p>
<p align="center">13 ARBOR Corridor Extension (ACE)</p>	<p>Includes all 8 river sub-reaches, with channels in key locations and treatments into Downtown LA, but not at the Cornfield/LA State Historic Park</p>	<p>R1A11 R2A11 R3A16 R4A16 R5A16 R6A13 R7A12 R8A15</p>
<p align="center">16 ARBOR Narrows to Downtown (AND)</p>	<p>Includes all river sub-reaches and sub-reaches 1-4 are similar to the smaller two alternatives. Sub-reach 5 includes channel widening and terracing, includes restoration of Arroyo Seco and Piggyback Yard.</p>	<p>R1A11 R2A11 R3A16 R4A16 R5A5 R6A13 R7A12 R8A3</p>
<p align="center">20 ARBOR Riparian Integration via Varied Ecological Reintroduction (RIVER)</p>	<p>Most extensive, includes measures in all 8 sub-reaches with channel widening at Verdugo Wash, Arroyo Seco, Cornfield/LA State Historic Park, and Piggyback Yard</p>	<p>R1A11 R2A13 R3A18 R4A16 R5A5 R6A13 R7A16 R8A3</p>

6.2 Alternative Reach Descriptions

A summary of restoration activities for Alternatives 10, 13, 16, and 20 is listed below by sub-reach.

6.2.1 Alternative 10 ARBOR Riparian Transitions (ART)

Alternative 10 includes restoration in all reaches (1-8) throughout the study area. Sub-measures under this alternative include:

- Riparian planting of habitat corridors (reaches 1,2,4,5,6,8)
- Expose/daylight stormdrain outlets (reaches 3,4,5,7)
- Restoration of open water habitat (reach 3)
- Channel widening (reach 6)
- Create/rebuild channel geomorphology (reaches 4,6,8)
- Divert flows into channels (reach 4)

Following is a reach-by-reach description of restoration measures:

Reach 1 – Riparian planting and restoration of riparian habitat corridors out of the channel along the tops of both banks would be implemented.

Reach 2 – Riparian planting and restoration of riparian habitat corridors out of the channel along the tops of both banks would be implemented.

Reach 3 – Selected storm drain outlets in this reach would be daylighted and reconstructed to create freshwater marsh habitat on the overbank area of the channel. Targeted storm drain locations for this reach include a large storm drain outlet on the right bank downstream of Ferraro Fields in the Zoo Drive Area and two smaller storm drains on the left bank. Open water habitat would also be restored at select areas.

Reach 4 – Riparian planting and restoration of riparian habitat corridors out of the channel along the top of left bank would be implemented. Selected storm drain outlets in this reach would be daylighted and reconstructed to create freshwater marsh habitat on the overbank area of the channel and include six storm drains on the left bank and one storm drain on the right bank. Channel diversions using the main channel flows would be constructed on the right bank through the Griffith Park area to provide sufficient flows for restored riparian and marsh habitat. Geomorphology would be created in select areas to enhance riparian and in-stream habitat.

Reach 5 – Riparian planting and restoration of riparian habitat corridors out of the channel along the top of left bank would be implemented. A storm drain outlet, located on the left bank, would be daylighted and reconstructed to create freshwater marsh habitat.

Reach 6 – Riparian planting and restoration of riparian habitat corridors out of the channel along the top of left bank would be implemented. Construction of a small vegetated terrace area along the left bank would be created by bringing down the concrete channel top of bank towards the River. The channel would be widened and reconfigured on the left bank to restore riparian habitat along the Taylor Yard ‘bowtie’ parcel. Channel geomorphology would be rebuilt in this reach to provide habitat features supportive of in-stream biota.

Reach 7 – Selected storm drain outlets in this reach would be daylighted and reconstructed to create freshwater marsh habitat on the overbank area of the channel and include one storm drain on the left bank, and two storm drains on the right bank.

Reach 8 – Riparian planting and restoration of riparian habitat corridors out of the channel along the Piggy Back Yard area would be implemented. Channel geomorphology would be rebuilt in this reach to provide habitat features supportive of in-stream biota.

6.2.2 Alternative 13 ARBOR Corridor Extension (ACE)

Features of Alternative 13 are similar to those included in Alternative 10, but also include a channel reshaping measure (trapezoidal to vertical walls). Restoration under this alternative would be implemented in all reaches (1-8) throughout the study area and include:

- Riparian planting of habitat corridors (reaches 1,2,3,4,5,6,7,8)
- Expose/daylight stormdrain outlets (reaches 3,4,5)
- Channel widening (reach 6,7)
- Create/rebuild channel geomorphology (reaches 3,4,6,8)
- Divert flow into channels (reaches 3,4)
- Planting built into walls (reaches 6,7)

Reach 1 – Riparian planting and restoration of riparian habitat corridors out of the channel along the tops of both banks would be implemented.

Reach 2 – Riparian planting and restoration of riparian habitat corridors out of the channel along the tops of both banks would be implemented.

Reach 3 – Riparian planting and restoration of riparian habitat corridors out of the channel along the top of the right bank would be implemented. Selected storm drain outlets would be daylighted and reconstructed to create freshwater marsh habitat on the overbank area of the channel and include a large storm drain outlet on the right bank downstream of Ferraro Fields in the Zoo Drive Area, and three smaller storm drains on the left bank. Channel flows would be diverted and connected to the large daylighted storm drain downstream of Ferraro Fields, to provide flows through restored marsh habitat. Channel geomorphology would be rebuilt in this reach to provide habitat features and flow regimes supportive of in-stream biota.

Reach 4 – Riparian planting and restoration of riparian habitat corridors out of the channel along the top of the left bank would be implemented. Selected storm drain outlets would be daylighted and reconstructed to create freshwater marsh habitat on the overbank area of the channel and include six storm drains on the left bank and one storm drain outlet on the right bank. Channel flows would be diverted and connected to marsh habitat, created through the daylighting and restoration of storm drain outlets. Channel geomorphology would be rebuilt in this reach to provide habitat features and flow regimes supportive of in-stream biota.

Reach 5 – Riparian planting and restoration of riparian habitat corridors out of the channel along the top of the left bank would be implemented. A storm drain outlet on the left bank would be daylighted and reconstructed to create freshwater marsh habitat on the overbank area of the channel.

Reach 6 – The main channel would be reconfigured and widened to take advantage of the Taylor Yard ‘Bowtie’ parcel. This section of the channel (the ‘Bowtie’ parcel) would be widened on the left bank to allow an increase in the channel invert width and to set-back the channel slope to meet the original ground elevation. Planter boxes would be built into channel walls on the right bank for vegetation planting/establishment through the entire reach. Riparian planting and restoration of riparian habitat corridors out of the channel along the top of the bank would be implemented. Trapezoidal walls in this reach would be reshaped to vertical to increase channel invert width. Channel geomorphology would be rebuilt in this reach to provide habitat features and flow regimes supportive of in-stream biota.

Reach 7 – Planter boxes would be built into channel walls to provide bank substrate for vegetation planting/establishment through a portion of the left bank to the downstream extent and the entire right bank. Removal of concrete and reconfiguration of the Arroyo Seco channel cross-section and riparian planting would be implemented to support riparian habitat restoration. Riparian planting and restoration of riparian habitat corridors out of the channel at the Arroyo Seco confluence along the top of both banks would be implemented.

Reach 8 – Riparian planting and restoration of riparian habitat corridors out of the channel along the Piggy Back Yard area would be implemented. Channel geomorphology would be rebuilt in this reach to provide habitat features supportive of in-stream biota. Existing railroad tracks within the Piggyback Yard parcel would be elevated on trestles to allow flow through and connection of the riparian zone and marsh habitat to the main channel.

6.2.3 Alternative 16 ARBOR Narrows to Downtown (AND)

Features of Alternative 16 are similar to those included in Alternative 13, but also include channel bed deepening and terrace banks sub-measures. Sub-measures under this alternative would be implemented in all reaches (1-8) throughout the study area and include:

- Riparian planting of habitat corridors (reaches 1,2,3,4,5,6,7,8)
- Expose/daylight stormdrain outlets (reaches 3,4,5)
- Channel widening (reach 7,8)

- Create/rebuild channel geomorphology (reaches 3,4,5,8)
- Divert flow into channels (reaches 3,8)
- Channel bed deepening (reach 5)
- Terrace banks (reaches 5,6,8)
- Bioengineer channel walls (reach 5)
- Planting built into walls (reaches 6,7)

Reach 1 – Riparian planting and restoration of riparian habitat corridors out of the channel along the tops of both banks would be implemented.

Reach 2 – Riparian planting and restoration of riparian habitat corridors out of the channel along the tops of both banks would be implemented.

Reach 3 – Riparian planting and restoration of riparian habitat corridors out of the channel along the top of the right bank would be implemented. Storm drain outlets would be daylighted and reconstructed to create freshwater marsh habitat on the overbank area of the channel. Outlets selected include a large storm drain outlet on the right bank downstream of Ferraro Fields in the Zoo Drive Area, and three smaller storm drains on the left bank. Channel flows would be diverted and connected to the large daylighted storm drain outlet downstream of Ferraro Fields, providing flows supportive of restored marsh habitat. Channel geomorphology would be rebuilt in this reach to provide habitat features and flow regimes supportive of in-stream biota.

Reach 4 – Riparian planting and restoration of riparian habitat corridors out of the channel along the top of the left bank would be implemented. Selected storm drain outlets would be daylighted and reconstructed to create freshwater marsh habitat on the overbank area of the channel and include one storm drain outlet on the right bank, and six storm drains on the left bank. Channel flows would be diverted by a constructed channel, and connected to restored riparian and marsh habitat. Channel geomorphology would be rebuilt in this reach to provide habitat features and flow regimes supportive of in-stream biota.

Reach 5 – Riparian planting and restoration of riparian habitat corridors out of the channel along the top of the left bank would be implemented. A storm drain outlet on the left bank would be daylighted and reconstructed to create freshwater marsh habitat on the overbank area of the channel. Channel geomorphology would be rebuilt in this reach to provide habitat features and flow regimes supportive of in-stream biota.

The left bank of the channel would be constructed to transition from trapezoidal to vegetated terraces. The five terraces would be 12 feet wide by 4 feet deep and tie into the existing ground elevation. The left bank would then transition from terraces to a vertical configuration and then transition back into the design channel configuration, before the channel passes under the Glendale Freeway.

The right bank of the channel would be reshaped from trapezoidal to vertical configuration and the channel invert would be widened to provide additional in-stream habitat. Channel walls on the right bank would be bioengineered, a 2-foot-by-2-foot notch along the top of right channel would be constructed for hanging vines.

Reach 6 – The main channel would be reconfigured and widened to take advantage of the Taylor Yard ‘Bowtie’ parcel. This section of the channel (‘Bowtie’ parcel) would be widened on the left bank to allow a channel invert width increase and to set the channel slope back to meet the original ground elevation. Planter boxes would be built into channel walls on the right bank for vegetation planting/establishment through the entire reach. Riparian planting and restoration of riparian habitat corridors out of the channel along the top of the bank would be implemented. Channel geomorphology would be rebuilt in this reach to provide habitat features and flow regimes supportive of in-stream biota.

Reach 7 – Planter boxes would be built into channel walls to provide bank substrate for vegetation planting/establishment through a portion of the left bank to the downstream extent and the entire right bank. Removal of concrete and reconfiguration of the Arroyo Seco channel cross-section and riparian planting would be implemented to support riparian habitat restoration. Riparian planting and restoration of riparian habitat corridors out of the channel at the Arroyo Seco confluence along the top of both banks would be implemented.

Reach 8 – Riparian planting and restoration of riparian habitat corridors out of the channel along the Piggy Back Yard area would be implemented. Channel geomorphology would be created or rebuilt to provide habitat features supportive of in-stream biota. Several 3-foot-deep vegetated terraces would be constructed along the right bank within the extent of the LADWP parking lot, which would tie into the existing ground at the top of the channel bank.

The main channel would be reconfigured to take advantage of the Piggyback Yard parcel; the channel invert width would be increased up to 500 feet. A 1,000-foot-wide bench would be constructed and would include marsh vegetation. A channel would be constructed through the Piggyback Yard, used to divert main channel flows supportive of marsh habitat. Existing railroad tracks within the Piggyback Yard parcel would be elevated on trestles to allow flow through and main channel connectivity to the riparian zone, channel, and marsh habitats.

6.2.4 Alternative 20 ARBOR Riparian Integration via Varied Ecological Reintroduction (RIVER)

This alternative provides the most extensive restoration and includes measures in all eight reaches with channel widening at Verdugo Wash, Arroyo Seco, Cornfield/LA State Historic Park, and Piggyback Yard. Features of Alternative 20 are similar to those included in Alternative 13, but are more extensive in scope. Sub-measures under this alternative would be implemented in all reaches (1-8) throughout the study area and include:

- Riparian planting of habitat corridors (reaches 1,2,3,4,5,6,7,8)
- Bioengineer channel walls (reach 5)
- Trapezoidal to vertical walls (reaches 4,5,7)

- Create/rebuild channel geomorphology (reaches 3,4,5,7,8)
- Divert flow into channels (reaches 3,4,7,8)
- Widen channel (reach 3,8)
- Widen tributaries (reach 3)
- Expose/daylight stormdrain outlets (reaches 4,5,7)
- Channel bed deepening (reach 5)
- Terrace banks (reaches 5,6,8)
- Elevate railroad (reaches 7,8)

Reach 1 – Riparian planting and restoration of riparian habitat corridors out of the channel along the tops of both banks would be implemented.

Reach 2 – Riparian planting and restoration of riparian habitat corridors out of the channel along the tops of both banks would be implemented. The right bank of the channel would be reshaped from a trapezoidal to vertical configuration and would include a 2-foot-by-2-foot notch along the top of the channel for hanging vines.

Reach 3 – Riparian planting and restoration of riparian habitat corridors out of the channel along the top of the right bank would be implemented. Channel flows would be diverted through a constructed channel along the right bank behind Ferraro Fields; the channel would connect main channel flows with restored marsh and riparian habitat areas. Channel geomorphology would be created in this reach to provide habitat features and flow regimes supportive of in-stream biota. Verdugo Wash would be restored to a soft bottom channel and widened to provide marsh habitat from its confluence with the Los Angeles River to 1,200 feet upstream.

Reach 4 – Riparian planting and restoration of riparian habitat corridors out of the channel along the top of the left bank would be implemented. Storm drain outlets would be daylighted and reconstructed to create freshwater marsh habitat on the overbank area of the channel and include one storm drain outlet on the right bank, and six storm drains on the left bank. Channel flows would be diverted by a constructed channel and connected to restored riparian and marsh habitat. Channel geomorphology would be rebuilt in this reach to provide habitat features and flow regimes supportive of in-stream biota.

Reach 5 – Riparian planting and restoration of riparian habitat corridors out of the channel along the top of the left bank would be implemented. A storm drain outlet on the left bank would be daylighted and reconstructed to create freshwater marsh habitat on the overbank area of the channel. Channel geomorphology would be rebuilt in this reach to provide habitat features and flow regimes supportive of in-stream biota.

The left bank of the channel would be constructed to transitions from trapezoidal to vegetated terraces. The five terraces would be 12 feet wide by 4 feet deep and tie into the existing ground

elevation. The left bank would then transition from terraces to a vertical configuration and then transition back into the design channel configuration, before the channel passes under the Glendale Freeway.

The right bank of the channel would be reshaped from trapezoidal to vertical configuration and the channel invert would be widened to provide additional in-stream habitat. Channel walls on the right bank would be bioengineered; a 2-foot-by-2-foot notch along the top of right channel would be constructed for hanging vines.

Reach 6 – The main channel would be reconfigured and widened to take advantage of the Taylor Yard ‘Bowtie’ parcel. This section of the channel (‘Bowtie’ parcel) would be widened on the left bank to allow a channel invert width increase and to set the channel slope back to meet the original ground elevation. Planter boxes would be built into channel walls on the right bank for vegetation planting/establishment through the entire reach. Riparian planting and restoration of riparian habitat corridors out of the channel along the top of the bank would be implemented. Channel geomorphology would be rebuilt in this reach to provide habitat features and flow regimes supportive of in-stream biota.

Reach 7 – Storm drain outlets in this reach would be daylighted and reconstructed to create freshwater marsh habitat on the overbank area of the channel, and include one storm drain on the left bank, and two storm drains on the right bank. A channel would be constructed in the reach to create connectivity between the main channel and riparian and marsh habitats created through restoration and daylighting of storm drain outlets. Channel geomorphology would be rebuilt in this reach to provide habitat features and flow regimes supportive of in-stream biota. Existing railroad tracks on the right bank would be elevated on trestles to allow flow through and main channel hydrologic connection to the riparian zone, channel, and marsh habitats.

Removal of concrete and reconfiguration of the Arroyo Seco channel cross-section and riparian planting would be implemented to support riparian habitat restoration. Riparian planting and restoration of riparian habitat corridors out of the channel at the Arroyo Seco confluence along the top of both banks would be implemented.

Four 4-foot-deep terraces on the right bank would be added adjacent to the Cornfields site, with the western edge of the terrace sloped back up to the original ground elevation.

Reach 8 – Riparian planting and restoration of riparian habitat corridors out of the channel along the Piggyback Yard area would be implemented. Channel geomorphology would be created or rebuilt to provide habitat features supportive of in-stream biota. Several 3-foot-deep vegetated terraces would be constructed along the right bank within the extent of the LADWP parking lot, which would tie into the existing ground at the top of the channel bank.

The main channel would be reconfigured to take advantage of the Piggyback Yard parcel; the channel invert width would be increased up to 500 feet. A 1,000-foot-wide bench would be constructed and would include marsh vegetation. A channel would be constructed through the Piggyback Yard, used to divert main channel flows supportive of marsh habitat. Existing railroad tracks within the Piggyback Yard parcel would be elevated on trestles to allow flow through and main channel hydrologic connectivity to the riparian zone, channel, and marsh habitats.



**US Army Corps
of Engineers®**
Los Angeles District

Los Angeles River Ecosystem Restoration Feasibility Study

Attachment 1 – Alternatives Matrix

August 2013

This page intentionally left blank.

LOS ANGELES RIVER COST ESTIMATE
ALTERNATIVES MATRIX

	1	2	3	4	5	6	7	8	9	10	11	12	13	14	15	16	17	18	19				
Reach	Measure Type	Submeasure	Comprehensive	City - Alvarado to Cornfields	Banks & Tribs Only	Highest Scoring Objectives (over 3)	City - Los Feliz to Arroyo Seco	Corps Team	Highest objectives (over 5)	Charette Team 1	Soft Bottom & Channel associated banks	Highest Other Criteria (over 11)	Charette Team 4	Charette Team 3	Charette Team 6	Charette Team 5	Charette Team 2	Side Channels Only	Charette Team 7	Comprehensive Pockets	Taylor Yard		
Brazil to Los Feliz Blvd	I. Adjacent or off channel modifications	3.5. create geomorphology and plant for freshwater marsh, open water le pool/trifle system	X	X	X	X						X						X					
		2. expose stormdrain outlets; convert to natural stream confluence. & divert to water quality ponds as needed (put in adjacent channel etc)	X	X	X	X	X				X												
	II. Attenuation	4. grade adjacent areas to a lower elevation for habitat & offine retention	X	X	X	X	X								X								
		10. divert tributary & river flow into side channels on both sides (minimize impacts to existing use in parks & plant near/natural habitat)	X	X	X	X	X										X						
		7. Create underground basins for attenuation - continue current use	X	X	X	X	X				X									X			
	III. Wildlife Access (formerly other)	9. culverts & or underground basins to divert flood flows	X	X	X	X	X				X												
		12. bridge undercrossings for wildlife	X	X	X	X	X												X				
		15. wildlife passage/tunnels	X	X	X	X	X												X				
	IV. Planting/implies soil amendments and geomorphic restructuring as needed	16. bioengineer channel walls (vines, vegetated notching near top of vertical walls)	X	X	X	X	X									X							
		17. habitat corridors/riparian planting on banks (assume easiest method)	X	X	X	X	X				X					X							
		21/22 widenchannel, provide erosion control may lower channel banks and provide setback levees or vegetated berms	X	X	X	X	X				X					X							
	V. Remove concrete (implies required erosion control such as grade control,planting and geomorphic restructuring, etc)	23. channel bed (implies deepening or attenuation)	X	X	X	X	X				X												
		25. terrace banks (check for connectivity vs too small once mapping is completed)	X	X	X	X	X				X					X							
		27. modify trap channel to vertical sides to gain width (adds capacity)	X	X	X	X	X				X					X							
	Costs	Construction		137,219,364	138,376,364	127,488,009	137,874,958	7,848,819	131,040,351	137,874,958	126,011,065	114,541,639	127,488,009	113,641,639	12,108,299	119,433,459	122,871,588	900,000	11,868,020		6,577,607	-	-
		Mobilization (7.5%)		10,291,452	10,378,227	9,561,601	10,340,622	588,661	9,828,026	10,340,622	9,450,830	8,590,623	9,561,601	8,523,123	908,122	8,957,509	9,215,369	67,500	890,102		493,321	-	-
Construction Subtotal			147,510,816	148,754,591	137,049,610	148,215,580	8,437,481	140,868,377	148,215,580	135,461,895	123,132,262	137,049,610	122,164,762	13,016,421	128,390,968	132,086,957	967,500	12,758,122		7,070,927	-	-	
Contingency (25%)			36,877,704	37,188,648	34,262,402	37,053,895	2,109,370	35,217,094	37,053,895	33,865,474	30,783,066	34,262,402	30,541,191	3,254,105	32,097,742	33,021,739	241,875	3,189,530		1,767,732	-	-	
PEDEDC (11%)			16,226,190	16,363,005	15,075,457	16,303,714	928,123	15,495,522	16,303,714	14,900,898	13,544,549	15,075,457	13,438,124	1,431,806	14,123,006	14,529,565	106,425	1,403,393		777,802	-	-	
SA (6.5%)			9,588,203	9,668,048	8,908,225	9,634,013	548,436	9,156,445	9,634,013	8,805,023	8,003,597	8,908,225	7,940,710	846,067	8,345,413	8,585,852	62,888	829,278		459,610	-	-	
Construction Period (Months)			43	43	35	39	17	36	39	35	27	32	26	15	33	27	13	15		15	-	-	
IDC			14,782,451	14,967,077	11,163,895	13,508,715	328,001	11,645,434	13,508,715	10,966,480	7,642,732	9,919,258	7,184,143	449,021	9,718,354	8,171,589	27,158	439,129		191,153	-	-	
LERRDS			19,830,552	19,830,552	19,001,697	19,792,938	19,756,075	19,820,195	19,792,938	18,802,694	17,300,599	18,974,422	17,578,612	18,353,356	16,799,997	634,224	17,993,208		562,014	-	-		
Total Cost Subtotal			244,815,916	246,772,921	225,461,286	244,508,854	32,107,486	232,203,067	244,508,854	222,802,375	200,406,804	224,189,374	198,847,541	36,546,115	211,028,839	213,195,499	2,040,069	36,612,660		10,829,238	-	-	
Annualized Construction Costs			10,912,478	10,999,710	10,049,761	10,898,791	1,431,166	10,350,270	10,898,791	9,931,242	8,932,977	9,993,066	8,863,474	1,629,151	9,406,446	9,503,023	90,935	1,631,981		482,705	-	-	
Annualized O&M Costs			554,898	554,898	545,049	547,377	500,101	547,377	500,101	461,521	461,521	545,049	452,521	61,329	496,293	454,849	59,000	142,528		106,277	-	-	
Total Annualized Costs		11,467,377	11,554,609	10,594,809	11,446,168	1,533,939	10,850,371	11,446,168	10,483,811	9,394,497	10,538,115	9,315,994	1,690,343	9,902,739	9,957,872	149,935	1,774,509		588,982	-	-		
S. Los Feliz to Glendale Fwy (2)	I. Adjacent or off channel modifications	3.5. create geomorphology and plant for freshwater marsh, open water le pool/trifle system	X	X	X	X						X			X								
		2. expose stormdrain outlets; convert to natural stream confluence. & divert to water quality ponds as needed (put in adjacent channel etc)	X	X	X	X	X				X								X				
	II. Attenuation	9. culverts & or underground basins to divert flood flows	X	X	X	X	X																
		14. wildlife access from river to bank (in daylighted storm drain)	X	X	X	X	X													X			
		7. Create underground basins for attenuation - continue current use	X	X	X	X	X				X												
	III. Wildlife Access (formerly other)	14. wildlife access from river to bank (in daylighted storm drain)	X	X	X	X	X																
		16. bioengineer channel walls (vines, vegetated notching near top of vertical walls)	X	X	X	X	X									X							
		17. habitat corridors/riparian planting on banks (assume easiest method)	X	X	X	X	X				X					X							
	IV. Planting/implies soil amendments and geomorphic restructuring as needed	23. channel bed (implies deepening or attenuation)	X	X	X	X	X				X					X							
		25. terrace banks (check for connectivity vs too small once mapping is completed)	X	X	X	X	X				X					X							
		27. modify trap channel to vertical sides to gain width (adds capacity)	X	X	X	X	X				X					X							
	Costs	Construction		87,401,820	87,401,820	31,784,946	55,367,624	87,401,820	100,000	55,367,624	149,250	100,000	-	31,784,946	-	55,516,874	-	-	100,000		-	-	-
		Mobilization (7.5%)		6,555,137	6,555,137	2,383,871	4,152,572	6,555,137	7,500	4,152,572	11,194	7,500	-	2,383,871	-	4,163,766	-	-	7,500		-	-	-
		Construction Subtotal		93,956,957	93,956,957	34,168,817	59,520,196	93,956,957	107,500	59,520,196	160,444	107,500	-	34,168,817	-	59,680,640	-	-	107,500		-	-	-
		Contingency (25%)		23,489,239	23,489,239	8,542,204	14,880,049	23,489,239	26,875	14,880,049	40,111	26,875	-	8,542,204	-	14,920,160	-	-	26,875		-	-	-
		PEDEDC (11%)		10,335,265	10,335,265	3,758,570	6,547,222	10,335,265	11,825	6,547,222	17,649	11,825	-	3,758,570	-	6,564,870	-	-	11,825		-	-	-
SA (6.5%)			6,107,202	6,107,202	3,868,813	6,107,202	6,988	3,868,813	6,107,202	10,429	6,988	-	2,220,973	-	3,879,242	-	-	6,988		-	-	-	
Construction Period (Months)			29	30	15	20	30	12	20	13	10	-	15	-	20	-	-	10		-	-	-	
IDC			6,278,039	6,559,371	1,161,876	2,647,887	6,559,371	2,877	2,647,887	4,752	2,270	-	2,657,915	-	2,657,915	-	-	2,270		-	-	-	
LERRDS			1,755,929	1,755,929	1,569,855	1,353,694	1,755,929	1,330,646	1,353,694	1,741,935	59,726	-	1,662,483	-	1,686,421	-	-	59,726		-	-	-	
Total Cost Subtotal			141,922,632	142,203,963	51,422,963	88,817,861	142,203,963	188,817,861	142,203,963	142,203,963	188,817,861	1,975,319	215,183	-	51,414,923	-	-	89,389,248		215,183	-	-	
Annualized Construction Costs			6,326,090	6,338,631	2,292,109	3,958,987	6,338,631	66,269	3,958,987	88,048	9,592	-	2,291,780	-	3,984,456	-	-	9,592		-	-	-	
Annualized O&M Costs			532,619	532,619	320,008	259,372	532,619	51,000	259,372	52,239	51,000	-	320,008	-	261,611	-	-	51,000		-	-	-	
Total Annualized Costs		6,858,709	6,871,250	2,612,116	4,218,359	6,871,250	117,269	4,218,359	140,287	60,592	-	2,611,788	-	4,246,067	-	-	60,592		-	-	-		
Glendale Fwy (2) to I-5	I. Adjacent or off channel modifications	3.5. create geomorphology and plant for freshwater marsh, open water le pool/trifle system	X	X	X	X						X			X								
		2. expose stormdrain outlets; convert to natural stream confluence. & divert to water quality ponds as needed (put in adjacent channel etc)	X	X	X	X	X						X						X				
	II. Attenuation	4. grade adjacent areas to a lower elevation for habitat & offine retention	X	X	X	X	X								X								
		9. culverts & or underground basins to divert flood flows	X	X	X	X	X																
		16. bioengineer channel walls (vines, vegetated notching near top of vertical walls)	X	X	X	X	X									X							
	III. Wildlife Access (formerly other)	14. wildlife access from river to bank (in daylighted storm drain)	X	X	X	X	X																
		16. bioengineer channel walls (vines, vegetated notching near top of vertical walls)	X	X	X	X	X									X							
		17. habitat corridors/riparian planting on banks (assume easiest method)	X	X	X	X	X				X					X							
	IV. Planting/implies soil amendments and geomorphic restructuring as needed	18. Planting bulk into channel walls (reshape concrete walls to accommodate vegetation or add hanging boxes (native vines, small shrubs, etc)	X	X	X	X	X						X		X	X							
		20. bring concrete down to channel level; reconfigure as soft bottom channel	X	X	X	X	X				X				X	X							
		21/22 widenchannel, provide erosion control may lower channel banks and provide setback levees or vegetated berms	X	X	X	X	X				X				X	X							
	V. Remove concrete (implies required erosion control such as grade control,planting and geomorphic restructuring, etc)	23. channel bed (implies deepening or attenuation)	X	X	X	X	X				X												
		25. terrace banks (check for connectivity vs too small once mapping is completed)	X	X	X	X	X				X					X							
		27. modify trap channel to vertical sides to gain width (adds capacity)	X	X	X	X	X				X					X							
	Costs	Construction		87,357,210	87,357,210	79,398,773	35,964,291	87,357,210	77,497,106	35,864,291	50,416,020	77,497,106	44,359,249	51,974,577	79,298,773	18,400,200	8,540,096	50,072,911	27,424,195	49,148,143	52,074,577	77,497,106	
		Mobilization (7.5%)		6,551,791	6,551,791	5,954,908	2,697,322	6,551,791	5,812,283	2,697,322	3,781,201	5,812,283	3,326,944	3,898,093	5,947,408	3,380,015	640,507	3,756,468	2,056,815	3,686,111	3,905,593	5,812,283	
Construction Subtotal			93,909,001	93,909,001	85,353,681	38,661,613	93,909,001	83,309,389	38,661,613	54,197,221	83,309,389	47,686,193	55,872,671	85,246,180	19,780,215	9,190,603	53,829,379	29,481,010	52,834,254	55,980,171	83,309,389		
Contingency (25%)			23,47																				

This page intentionally left blank.



**US Army Corps
of Engineers®**
Los Angeles District

Los Angeles River Ecosystem Restoration Feasibility Study

DRAFT

Attachment 2 - Utilities

On File

August 2013

This page intentionally left blank.



**US Army Corps
of Engineers®**
Los Angeles District

Los Angeles River Ecosystem Restoration Feasibility Study

DRAFT



















Attachment 3 – Final Array Maps

August 2013

This page intentionally left blank.

LEGEND

Sub-Measures

-  1. elevate railroads on trestles
-  2. expose stormdrain outlets; convert to natural stream confluence, & divert to water quality ponds as needed (put in adjacent channel etc)
-  3. create geomorphology and plant for freshwater marsh
-  4. grade adjacent areas to a lower elevation for habitat & offline retention
-  5. create geomorphology for open water
-  6. rebuild geomorphology for historic wash
-  8. creation of wetlands flood control basin (assumes culvert under Baker St)
-  10. divert tributary & river flow into side channels on both sides (minimize impacts to existing use in parks & plant riparian/marsh habitat)
-  12. bridge undercrossings for wildlife
-  14. wildlife access from river to bank (in daylighted storm drain)
-  16. bioengineer channel walls (vines, vegetated notching near top of vertical walls)
-  17. habitat corridors/ riparian planting on banks (assume easiest method)
-  19. Planting built into channel walls (reshape concrete walls to accommodate vegetation or add hanging boxes (native vines, small shrubs, etc)
-  21. lower channel banks and provide setback levees or vegetated berms
-  22. channel banks mainstem/widen channel (implies erosion control)
-  23. channel bed (implies deepening or attenuation)
-  25. tributary channels/widen channel (implies erosion control)
-  26. terrace banks (check for connectivity vs too small once mapping is completed)
-  27. modify trap channel to vertical sides to gain width (adds capacity)

This page intentionally left blank.



Sheet 1: Reach 1-3



Data Source: City of Los Angeles, USACE; 2011
Aerial Source: LARIC 2008

Alternative 10, ARBOR Riparian Transitions (ART)
Los Angeles River Ecosystem Restoration (Feb, 2013)

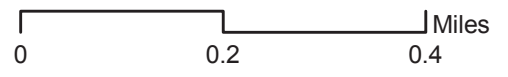

This page intentionally left blank.



Sheet 2: Reach 3-5



Data Source: City of Los Angeles, USACE; 2011
 Aerial Source: LARIC 2008

**Alternative 10, ARBOR Riparian Transitions (ART)
 Los Angeles River Ecosystem Restoration (Feb, 2013)**

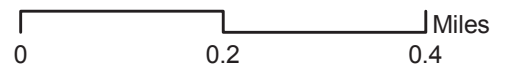

This page intentionally left blank.



Sheet 3: Reach 5-7



Data Source: City of Los Angeles, USACE; 2011
 Aerial Source: LARIC 2008

Alternative 10, ARBOR Riparian Transitions (ART)
Los Angeles River Ecosystem Restoration (Feb, 2013)

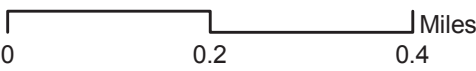

This page intentionally left blank.

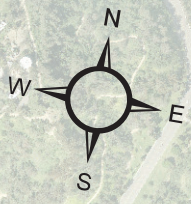
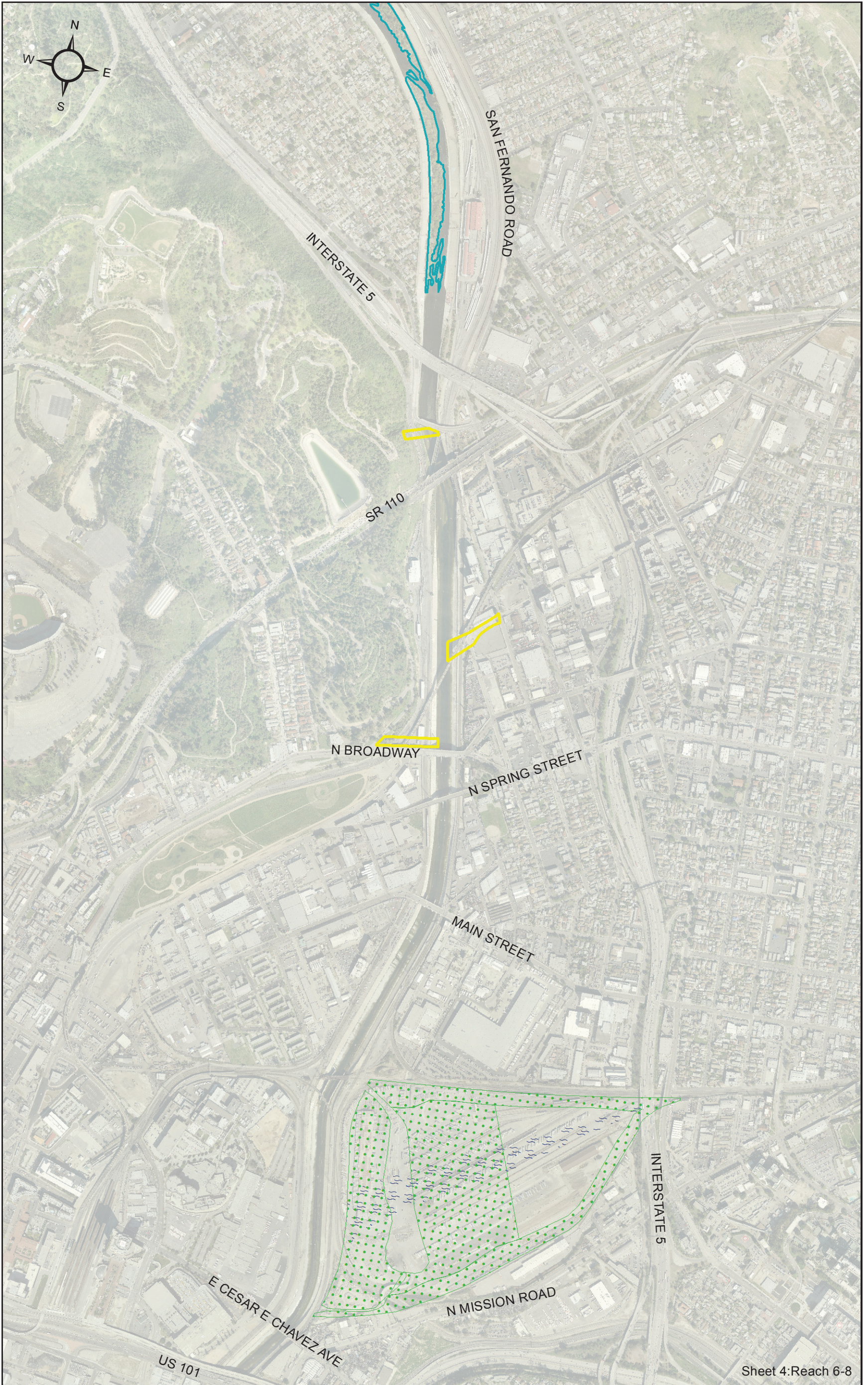

INTERSTATE 5

SAN FERNANDO ROAD

SR 110

N BROADWAY

N SPRING STREET

MAIN STREET

INTERSTATE 5

E CESAR E CHAVEZ AVE

N MISSION ROAD

US 101

Sheet 4: Reach 6-8



Data Source: City of Los Angeles, USACE; 2011
Aerial Source: LARIC 2008

Alternative 10, ARBOR Riparian Transitions (ART)
Los Angeles River Ecosystem Restoration (Feb, 2013)

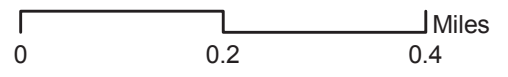

This page intentionally left blank.



Sheet 1: Reach 1-3



Data Source: City of Los Angeles, USACE; 2011
 Aerial Source: LARIC 2008

Alternative 13, ARBOR Corridor Extension (ACE)
Los Angeles River Ecosystem Restoration (Feb, 2013)

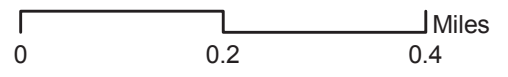

This page intentionally left blank.



Sheet 2: Reach 3-5



Data Source: City of Los Angeles, USACE; 2011
 Aerial Source: LARIC 2008

**Alternative 13, ARBOR Corridor Extension (ACE)
 Los Angeles River Ecosystem Restoration (Feb, 2013)**

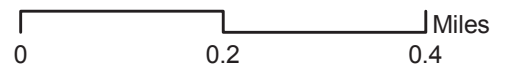

This page intentionally left blank.



Sheet 3: Reach 5-7



Data Source: City of Los Angeles, USACE; 2011
 Aerial Source: LARIC 2008

Alternative 13, ARBOR Corridor Extension (ACE)
Los Angeles River Ecosystem Restoration (Feb, 2013)

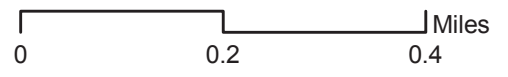

This page intentionally left blank.

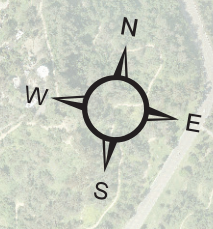
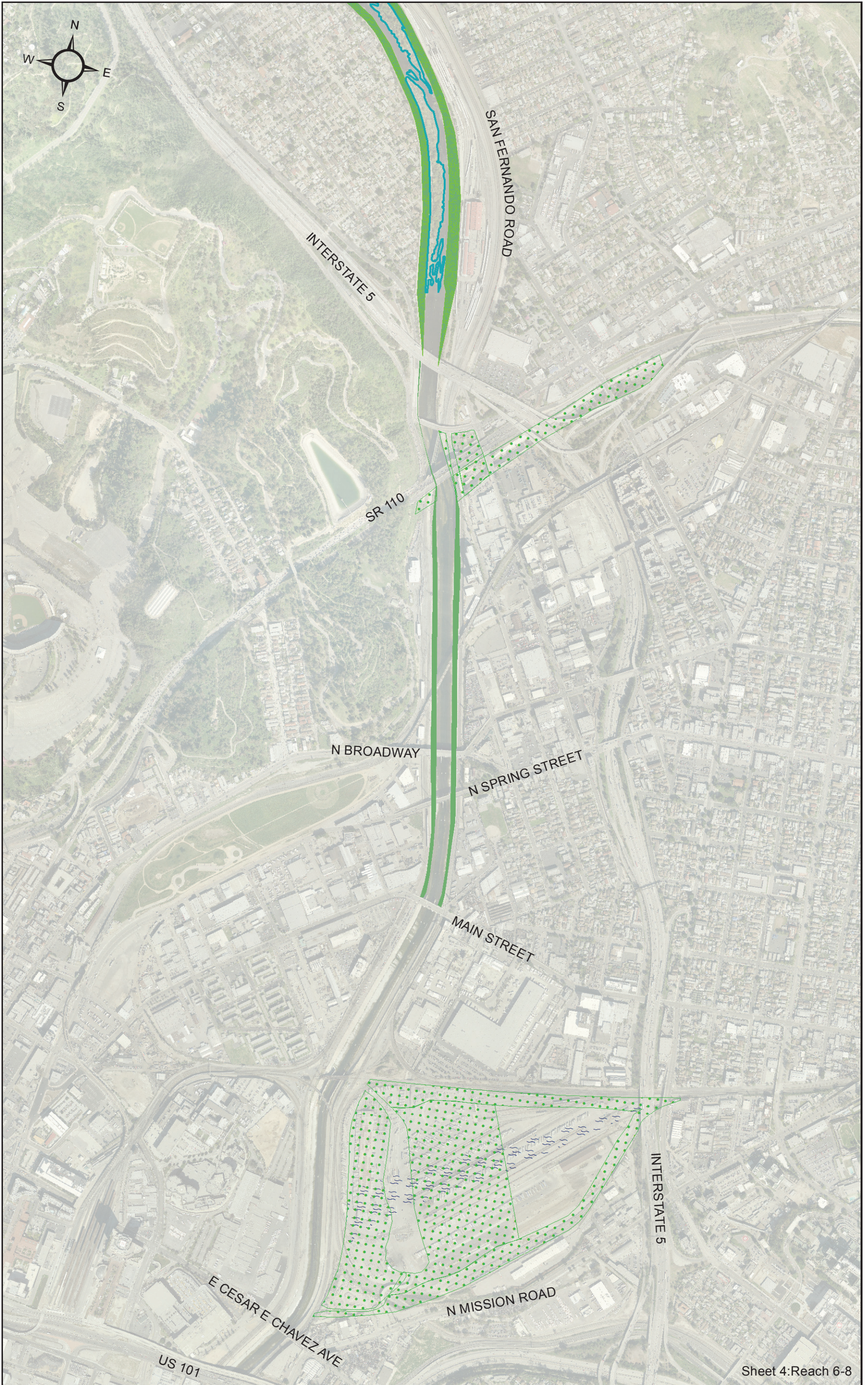

Sheet 4: Reach 6-8



Data Source: City of Los Angeles, USACE; 2011
 Aerial Source: LARIC 2008

Alternative 13, ARBOR Corridor Extension (ACE)
Los Angeles River Ecosystem Restoration (Feb, 2013)

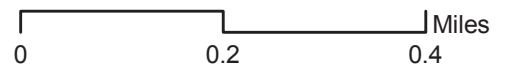

This page intentionally left blank.



Sheet 1: Reach 1-3



Data Source: City of Los Angeles, USACE; 2011
 Aerial Source: LARIC 2008

**Alternative 16, ARBOR Narrows to Downtown (AND)
 Los Angeles River Ecosystem Restoration (Feb, 2013)**

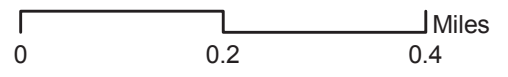

This page intentionally left blank.



Sheet 2: Reach 3-5



Data Source: City of Los Angeles, USACE; 2011
 Aerial Source: LARIC 2008

**Alternative 16, ARBOR Narrows to Downtown (AND)
 Los Angeles River Ecosystem Restoration (Feb, 2013)**

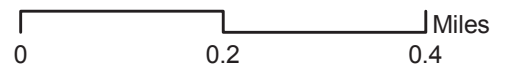

This page intentionally left blank.



Sheet 3: Reach 5-7



Data Source: City of Los Angeles, USACE; 2011
 Aerial Source: LARIC 2008

**Alternative 16, ARBOR Narrows to Downtown (AND)
 Los Angeles River Ecosystem Restoration (Feb, 2013)**

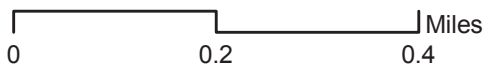

This page intentionally left blank.

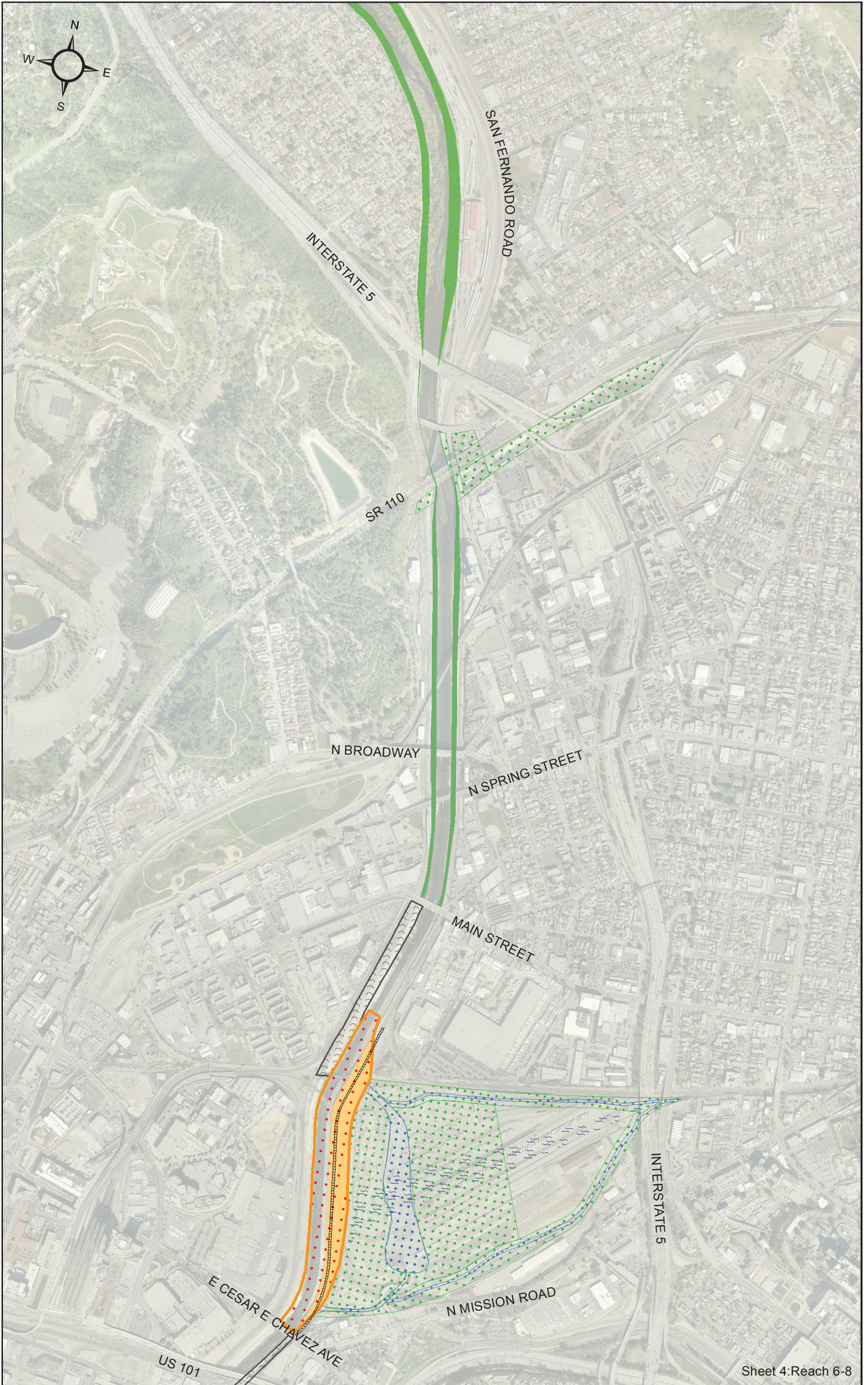

Sheet 4: Reach 6-8



Data Source: City of Los Angeles, USACE; 2011
 Aerial Source: LARIC 2008

**Alternative 16, ARBOR Narrows to Downtown (AND)
 Los Angeles River Ecosystem Restoration (Feb, 2013)**

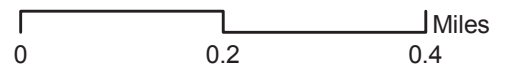

This page intentionally left blank.



Sheet 1: Reach 1-3



Data Source: City of Los Angeles, USACE; 2011
 Aerial Source: LARIC 2008

**Alternative 20, ARBOR, Riparian Integration
 via Varied Ecological Restoration (RIVER)**
 Los Angeles River Ecosystem Restoration (Feb, 2013)

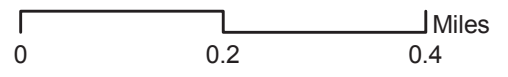

This page intentionally left blank.



Sheet 2: Reach 3-5



Data Source: City of Los Angeles, USACE; 2011
 Aerial Source: LARIC 2008

**Alternative 20, ARBOR, Riparian Integration
 via Varied Ecological Restoration (RIVER)
 Los Angeles River Ecosystem Restoration (Feb, 2013)**

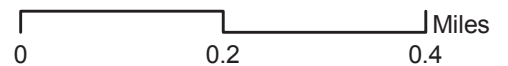

This page intentionally left blank.



Sheet 3: Reach 5-7



Data Source: City of Los Angeles, USACE; 2011
 Aerial Source: LARIC 2008

**Alternative 20, ARBOR, Riparian Integration
 via Varied Ecological Restoration (RIVER)**
 Los Angeles River Ecosystem Restoration (Feb, 2013)

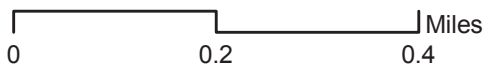

This page intentionally left blank.

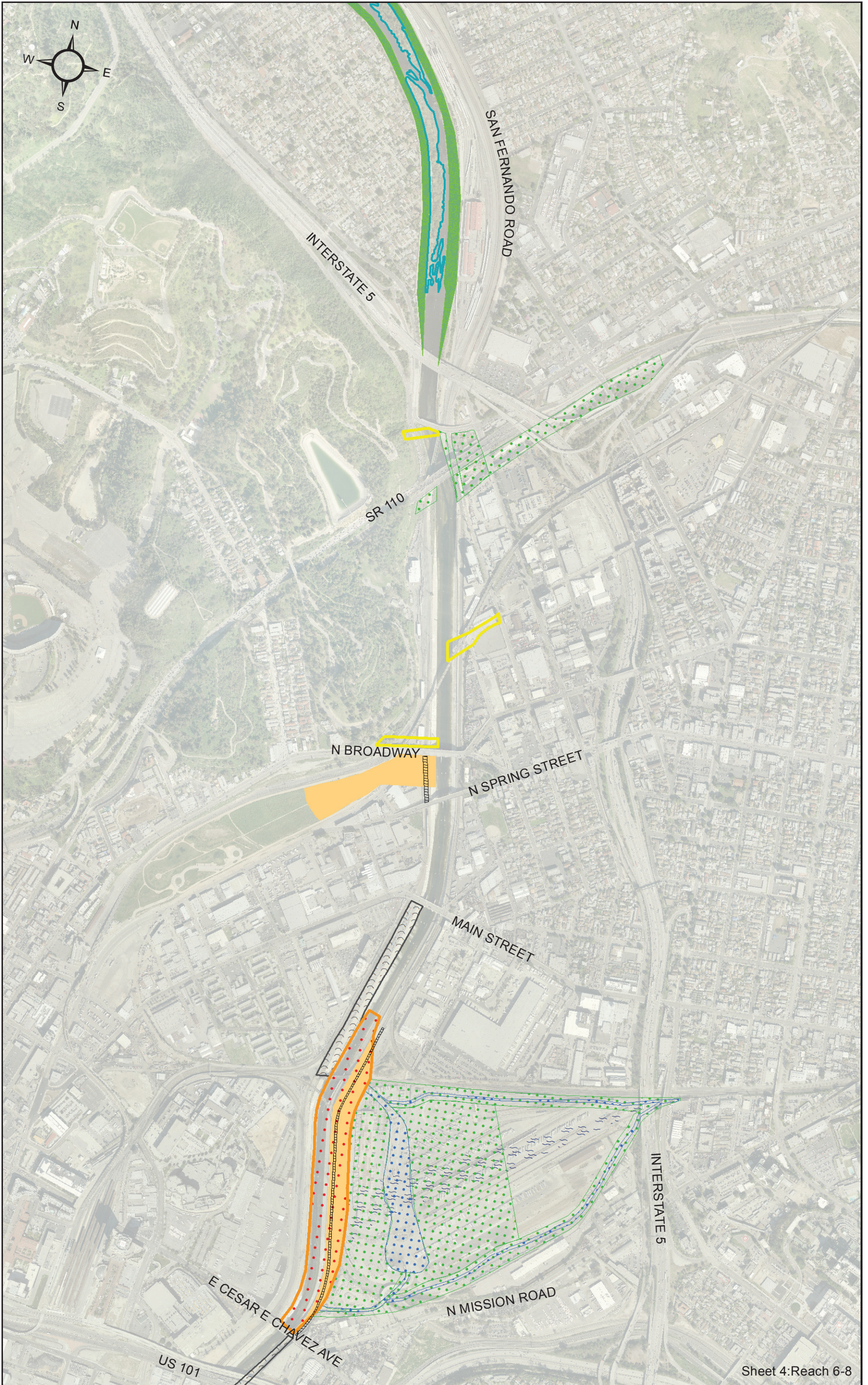

Sheet 4: Reach 6-8



Data Source: City of Los Angeles, USACE; 2011
 Aerial Source: LARIC 2008

**Alternative 20, ARBOR, Riparian Integration
 via Varied Ecological Restoration (RIVER)**
 Los Angeles River Ecosystem Restoration (Feb, 2013)

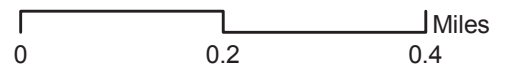

This page intentionally left blank.



**US Army Corps
of Engineers®**
Los Angeles District

Los Angeles River Ecosystem Restoration Feasibility Study

Attachment 4 – Revised Cross Sections

August 2013

This page intentionally left blank.

Attachment 4- Revised Cross Sections

Sheet	Alternative(s)	Location
1	Alternative 20	Reach 2
2	Alternatives 16 & 20	Reach 5
3	Alternatives 13,16 & 20	Reach 6
4	Alternative 10	Taylor Yard
5	Alternatives 13, 16 & 20	Taylor Yard
6	Alternative 13, 16, & 20	Reach 6
7	Alternatives 13 & 16	Reach 7
8	Alternatives 16 & 20	Piggyback Yard
9	Alternative 20	Verdugo Wash
10	Alternative 20	Verdugo Wash
11	Alternative 20	Verdugo Wash
12	Alternatives 13, 16 & 20	Arroyo Seco
13	Alternative 20	Cornfields

This page intentionally left blank.

THIS IS A PRELIMINARY, PLANNING-LEVEL, CONCEPTUAL IMAGE USED FOR COST ESTIMATING PURPOSES ONLY.

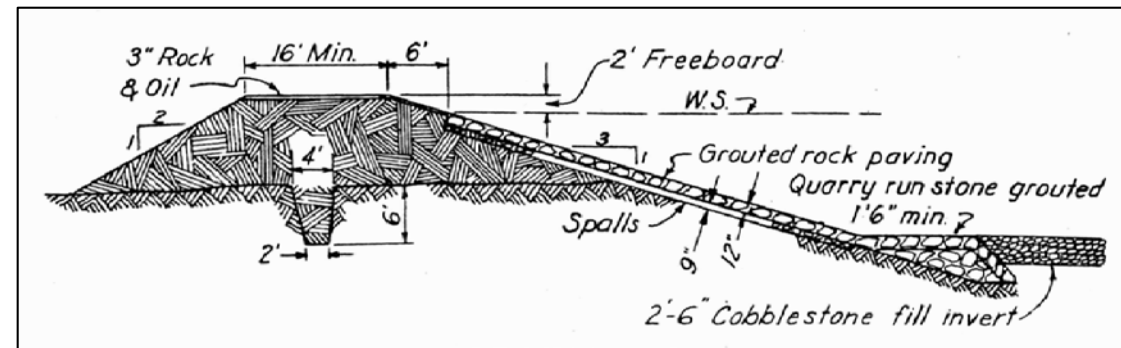
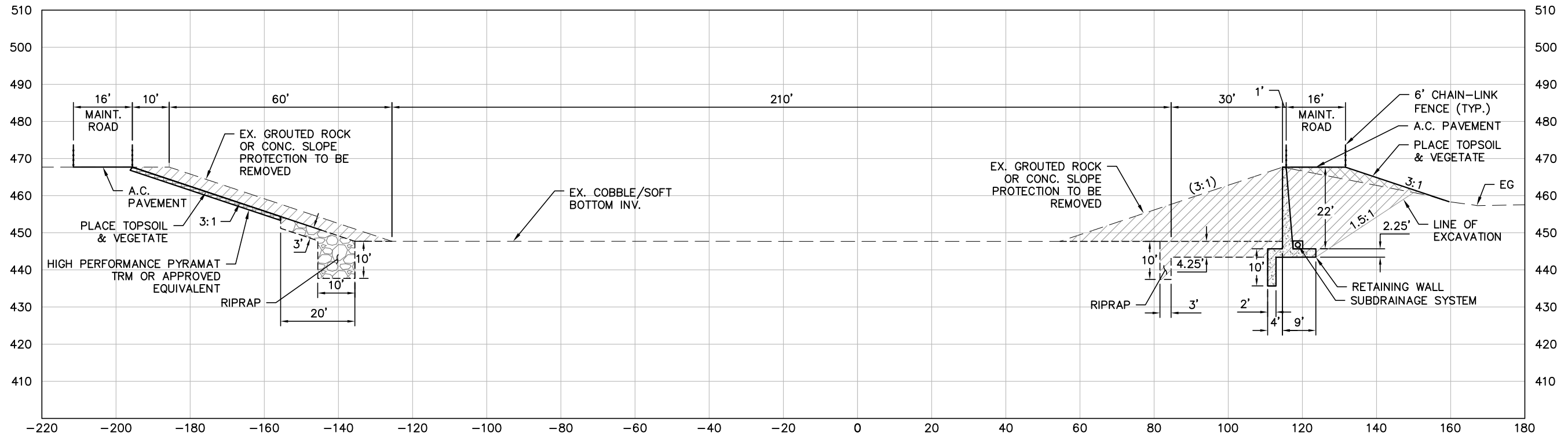

EXISTING TYPICAL SECTION
NTS

LEGEND

	EX. GROUND		RIPRAP
	PROPOSED CHANNEL		REINFORCED CONCRETE
	EXCAVATION		HIGH PERFORMANCE PYRAMAT TURF REINFORCEMENT MAT (TRM) OR APPROVED EQUIVALENT
	COMPACTED FILL		NOTE: ALL DIMENSIONS SHOWN ARE APPROXIMATE AND SUBJECT TO REVISIONS DURING FINAL DESIGN.

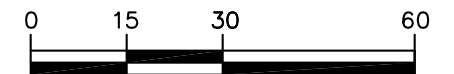

REVISIONS				LOS ANGELES RIVER FEASIBILITY STUDY PRELIMINARY DESIGN	DATE 04/16/13
MARK	DATE	DESCRIPTION	BY		
TETRA TECH, INC. 17885 Von Karman Avenue, Suite 500 Irvine, CA 92614 Phone (949) 809-5000, FAX (949) 809-5003				ALTERNATIVE 20 REACH 2 (R2A13)	SHT NO. 1 OF 13

This page intentionally left blank.

THIS IS A PRELIMINARY, PLANNING-LEVEL, CONCEPTUAL IMAGE USED FOR COST ESTIMATING PURPOSES ONLY.

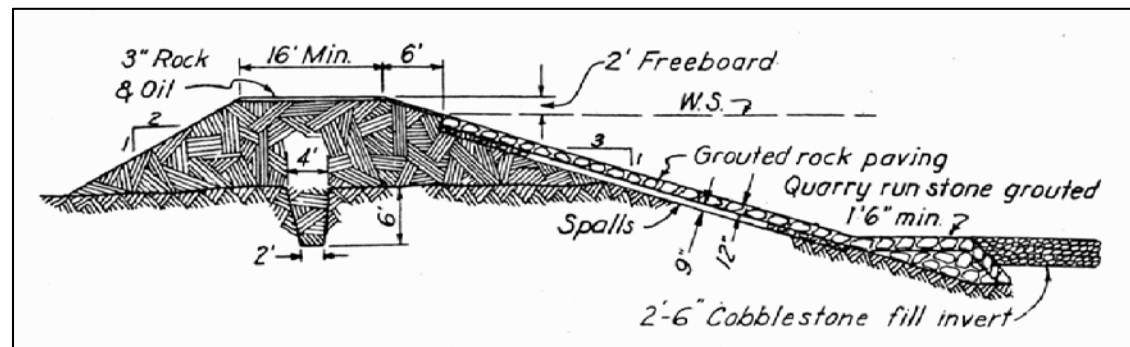
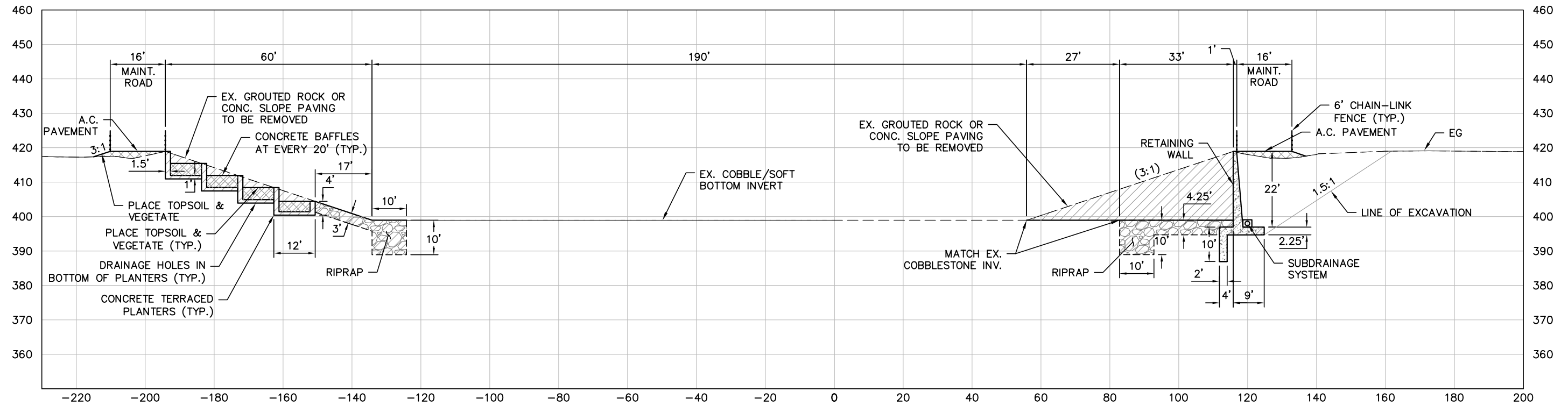

EXISTING TYPICAL SECTION
NTS

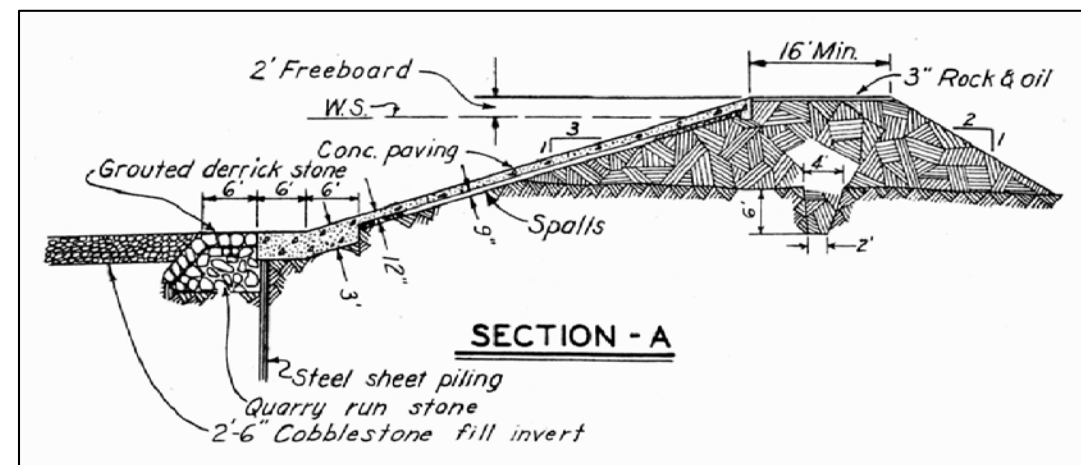

EXISTING TYPICAL SECTION
NTS

LEGEND

---	EX. GROUND		RIPRAP
—	PROPOSED CHANNEL		REINFORCED CONCRETE
	EXCAVATION		HIGH PERFORMANCE PYRAMAT TURF REINFORCEMENT MAT (TRM) OR APPROVED EQUIVALENT
	COMPACTED FILL		

NOTE: ALL DIMENSIONS SHOWN ARE APPROXIMATE AND SUBJECT TO REVISIONS DURING FINAL DESIGN.

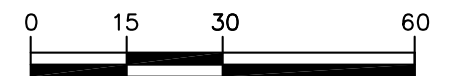

REVISIONS				LOS ANGELES RIVER FEASIBILITY STUDY PRELIMINARY DESIGN	DATE 04/16/13
MARK	DATE	DESCRIPTION	BY		
TETRA TECH, INC. 17885 Von Karman Avenue, Suite 500 Irvine, CA 92614 Phone (949) 809-5000, FAX (949) 809-5003				ALTERNATIVES 16 & 20 REACH 5 (R5A5)	SHT NO. 2 OF 13

This page intentionally left blank.

THIS IS A PRELIMINARY, PLANNING-LEVEL, CONCEPTUAL IMAGE USED FOR COST ESTIMATING PURPOSES ONLY.

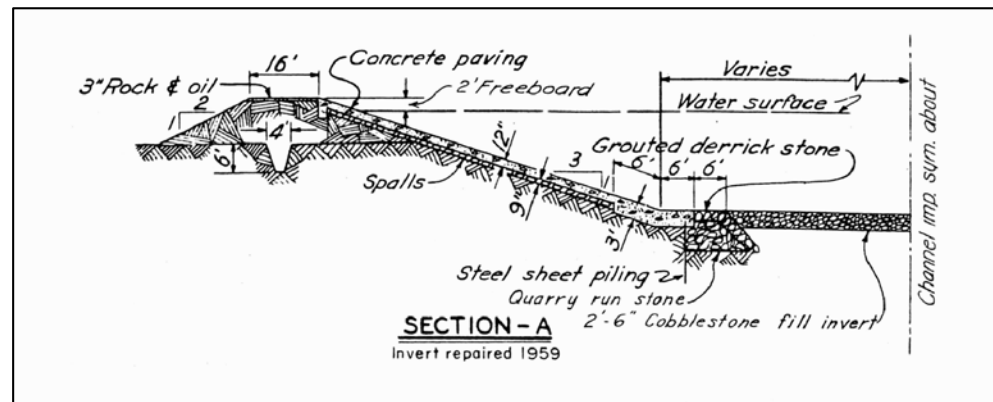

EXISTING TYPICAL SECTION
NTS

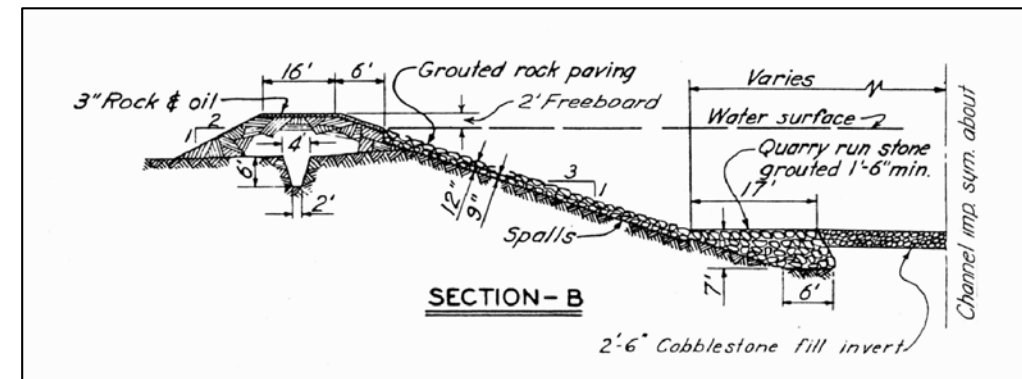

EXISTING TYPICAL SECTION
NTS

LEGEND

---	EX. GROUND		RIPRAP
—	PROPOSED CHANNEL		REINFORCED CONCRETE
	EXCAVATION		HIGH PERFORMANCE PYRAMAT TURF REINFORCEMENT MAT (TRM) OR APPROVED EQUIVALENT
	COMPACTED FILL		

NOTE: ALL DIMENSIONS SHOWN ARE APPROXIMATE AND SUBJECT TO REVISIONS DURING FINAL DESIGN

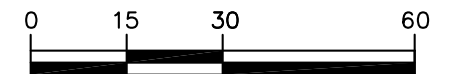

REVISIONS				LOS ANGELES RIVER FEASIBILITY STUDY PRELIMINARY DESIGN	DATE 04/16/13
MARK	DATE	DESCRIPTION	BY		
TETRA TECH, INC. 17885 Von Karman Avenue, Suite 500 Irvine, CA 92614 Phone (949) 809-5000, FAX (949) 809-5003				ALTERNATIVES 13, 16, & 20 REACH 6 (R6A13)	
				SHT NO. 3 OF 13	

This page intentionally left blank.

THIS IS A PRELIMINARY, PLANNING-LEVEL, CONCEPTUAL IMAGE USED FOR COST ESTIMATING PURPOSES ONLY.

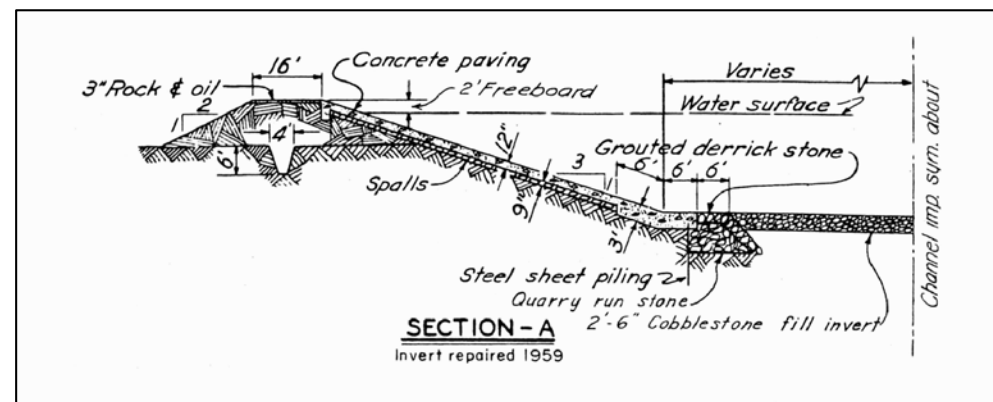

EXISTING TYPICAL SECTION
NTS

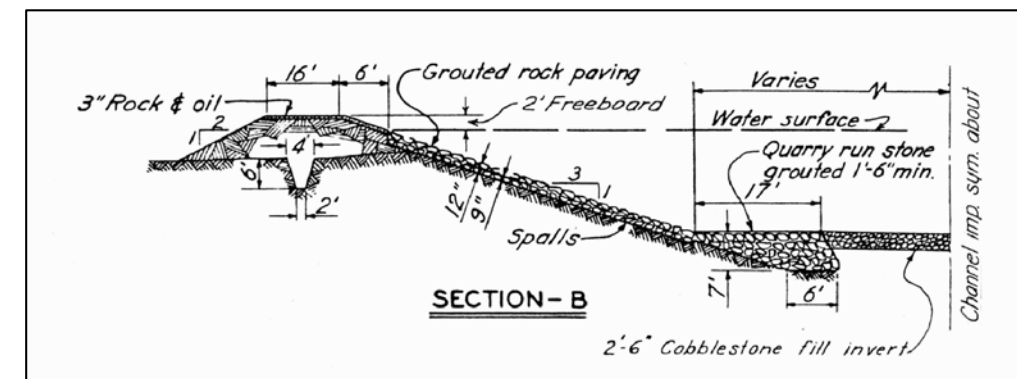

EXISTING TYPICAL SECTION
NTS

LEGEND

---	EX. GROUND		RIPRAP
---	PROPOSED CHANNEL		REINFORCED CONCRETE
	EXCAVATION		HIGH PERFORMANCE PYRAMAT TURF REINFORCEMENT MAT (TRM) OR APPROVED EQUIVALENT
	COMPACTED FILL		

NOTE: ALL DIMENSIONS SHOWN ARE APPROXIMATE AND SUBJECT TO REVISIONS DURING FINAL DESIGN

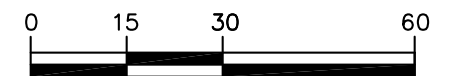

REVISIONS				LOS ANGELES RIVER FEASIBILITY STUDY PRELIMINARY DESIGN	DATE 04/16/13
MARK	DATE	DESCRIPTION	BY		
TETRA TECH, INC. 17885 Von Karman Avenue, Suite 500 Irvine, CA 92614 Phone (949) 809-5000, FAX (949) 809-5003				ALTERNATIVE 10 REACH 6 (R6A14)	SHT NO. 4 OF 13

This page intentionally left blank.

THIS IS A PRELIMINARY, PLANNING-LEVEL, CONCEPTUAL IMAGE USED FOR COST ESTIMATING PURPOSES ONLY.

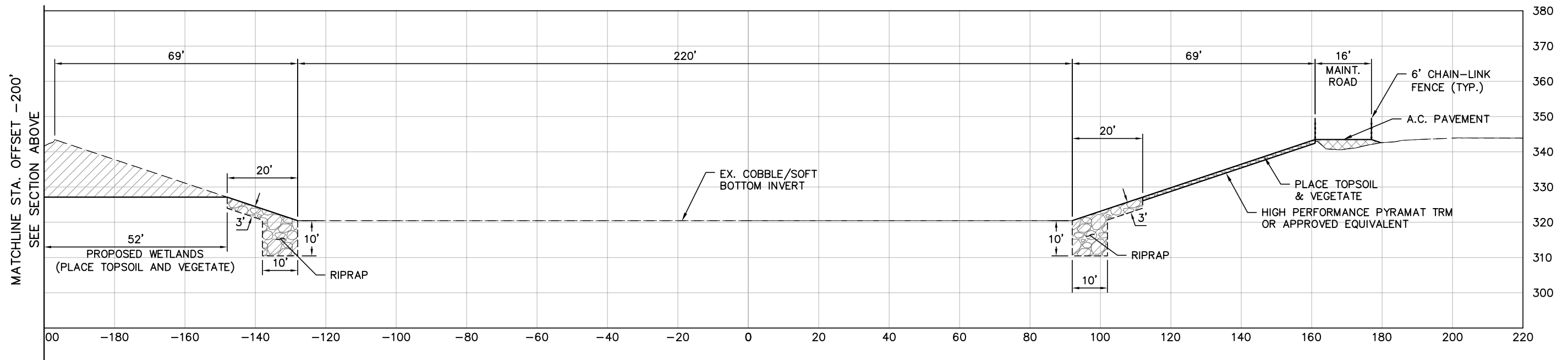
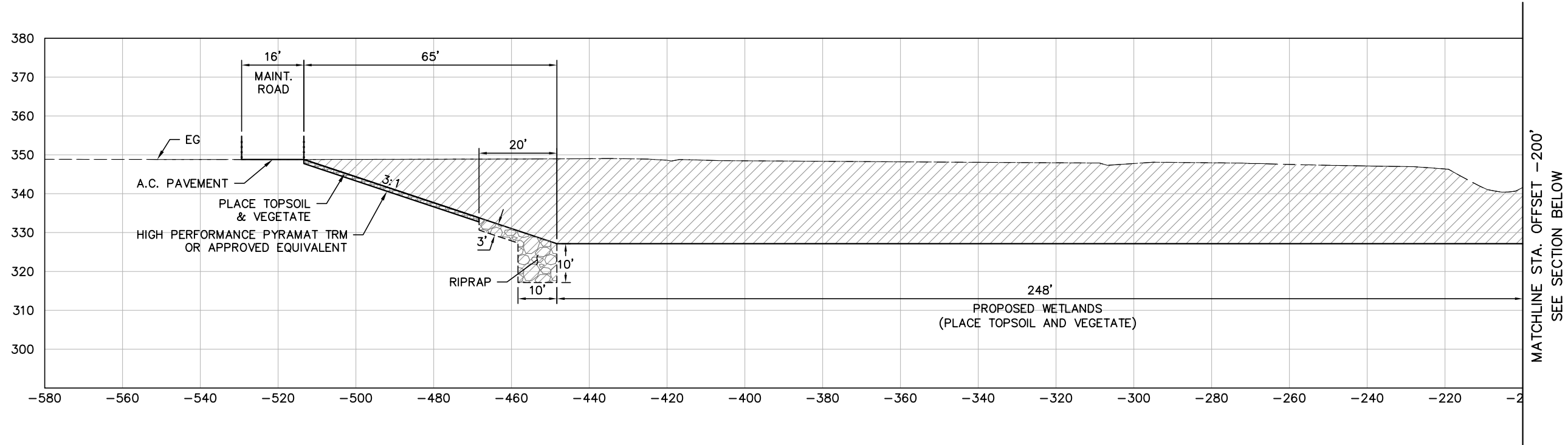

LEGEND

	EX. GROUND		RIPRAP
	PROPOSED CHANNEL		REINFORCED CONCRETE
	EXCAVATION		HIGH PERFORMANCE PYRAMAT TURF REINFORCEMENT MAT (TRM) OR APPROVED EQUIVALENT
	COMPACTED FILL		

NOTE: ALL DIMENSIONS SHOWN ARE APPROXIMATE AND SUBJECT TO REVISIONS DURING FINAL DESIGN.

NOTE: EXISTING TYPICAL SECTIONS PER SHEET 3



REVISIONS				LOS ANGELES RIVER FEASIBILITY STUDY PRELIMINARY DESIGN	DATE 04/16/13
MARK	DATE	DESCRIPTION	BY		
TETRA TECH, INC. 17885 Von Karman Avenue, Suite 500 Irvine, CA 92614 Phone (949) 809-5000, FAX (949) 809-5003				ALTERNATIVES 13, 16, & 20 REACH 6 (R6A13)	
				SHT NO. 5 OF 13	

This page intentionally left blank.

THIS IS A PRELIMINARY, PLANNING-LEVEL, CONCEPTUAL IMAGE USED FOR COST ESTIMATING PURPOSES ONLY.

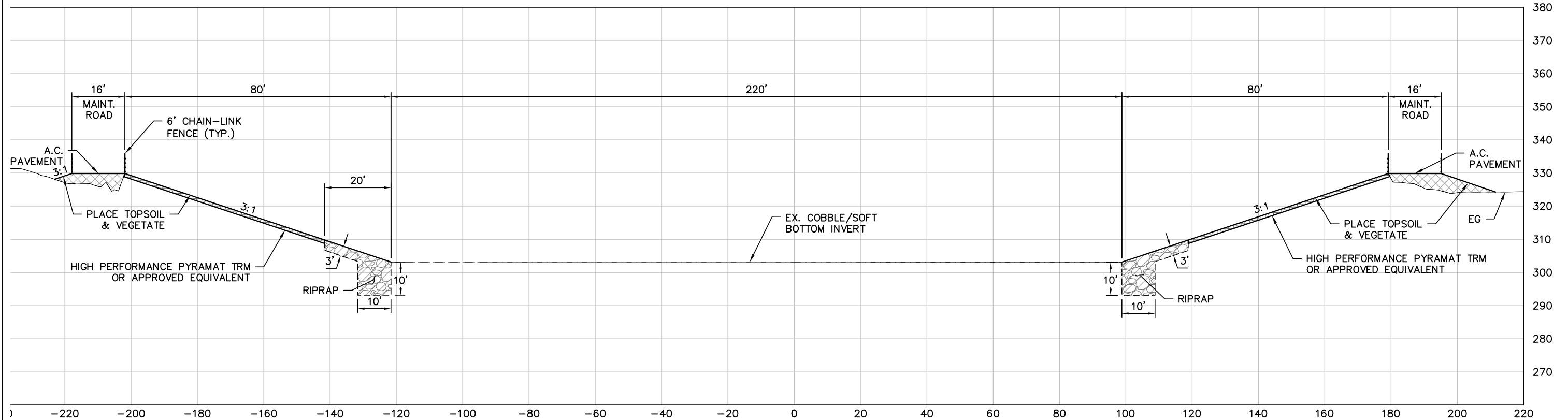

LEGEND

	EX. GROUND		RIPRAP
	PROPOSED CHANNEL		REINFORCED CONCRETE
	EXCAVATION		HIGH PERFORMANCE PYRAMAT TURF REINFORCEMENT MAT (TRM) OR APPROVED EQUIVALENT
	COMPACTED FILL		NOTE: ALL DIMENSIONS SHOWN ARE APPROXIMATE AND SUBJECT TO REVISIONS DURING FINAL DESIGN

NOTE: EXISTING TYPICAL SECTIONS PER SHEET 3

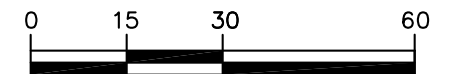

REVISIONS				LOS ANGELES RIVER FEASIBILITY STUDY PRELIMINARY DESIGN	DATE 04/16/13
MARK	DATE	DESCRIPTION	BY		
TETRA TECH, INC. 17885 Von Karman Avenue, Suite 500 Irvine, CA 92614 Phone (949) 809-5000, FAX (949) 809-5003				ALTERNATIVES 13, 16, & 20 REACH 6 (R6A13)	
				SHT NO. 6 OF 13	

This page intentionally left blank.

THIS IS A PRELIMINARY, PLANNING-LEVEL, CONCEPTUAL IMAGE USED FOR COST ESTIMATING PURPOSES ONLY.

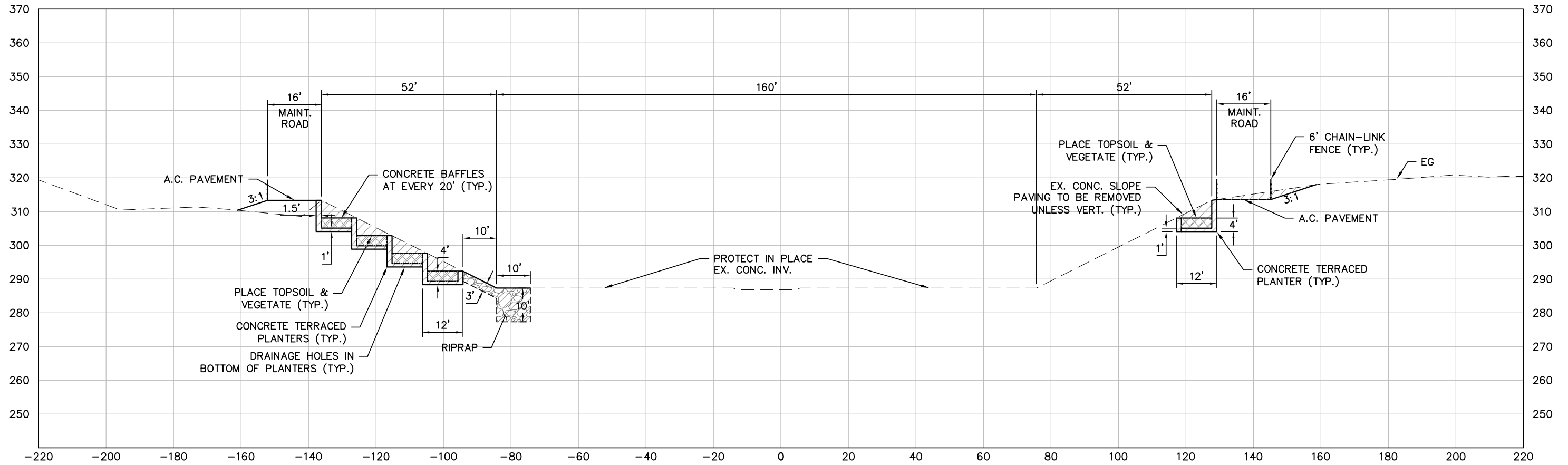

NOTE: EITHER DESIGN DEPENDENT ON HYDRAULIC ANALYSIS.

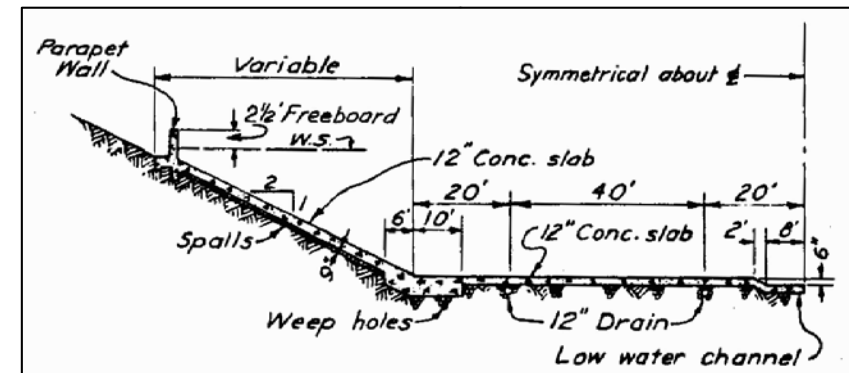

EXISTING TYPICAL SECTION
NTS

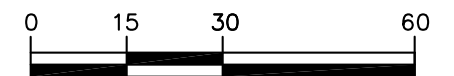

LEGEND

---	EX. GROUND		RIPRAP
—	PROPOSED CHANNEL		REINFORCED CONCRETE
	EXCAVATION		HIGH PERFORMANCE PYRAMAT TURF REINFORCEMENT MAT (TRM) OR APPROVED EQUIVALENT
	COMPACTED FILL		

NOTE: ALL DIMENSIONS SHOWN ARE APPROXIMATE AND SUBJECT TO REVISIONS DURING FINAL DESIGN.

REVISIONS				LOS ANGELES RIVER FEASIBILITY STUDY PRELIMINARY DESIGN	DATE 04/16/13
MARK	DATE	DESCRIPTION	BY		
TETRA TECH, INC. 17885 Von Karman Avenue, Suite 500 Irvine, CA 92614 Phone (949) 809-5000, FAX (949) 809-5003				ALTERNATIVES 13 & 16 REACH 7 (R7A12)	SHT NO. 7 OF 13

This page intentionally left blank.

THIS IS A PRELIMINARY, PLANNING-LEVEL, CONCEPTUAL IMAGE USED FOR COST ESTIMATING PURPOSES ONLY.

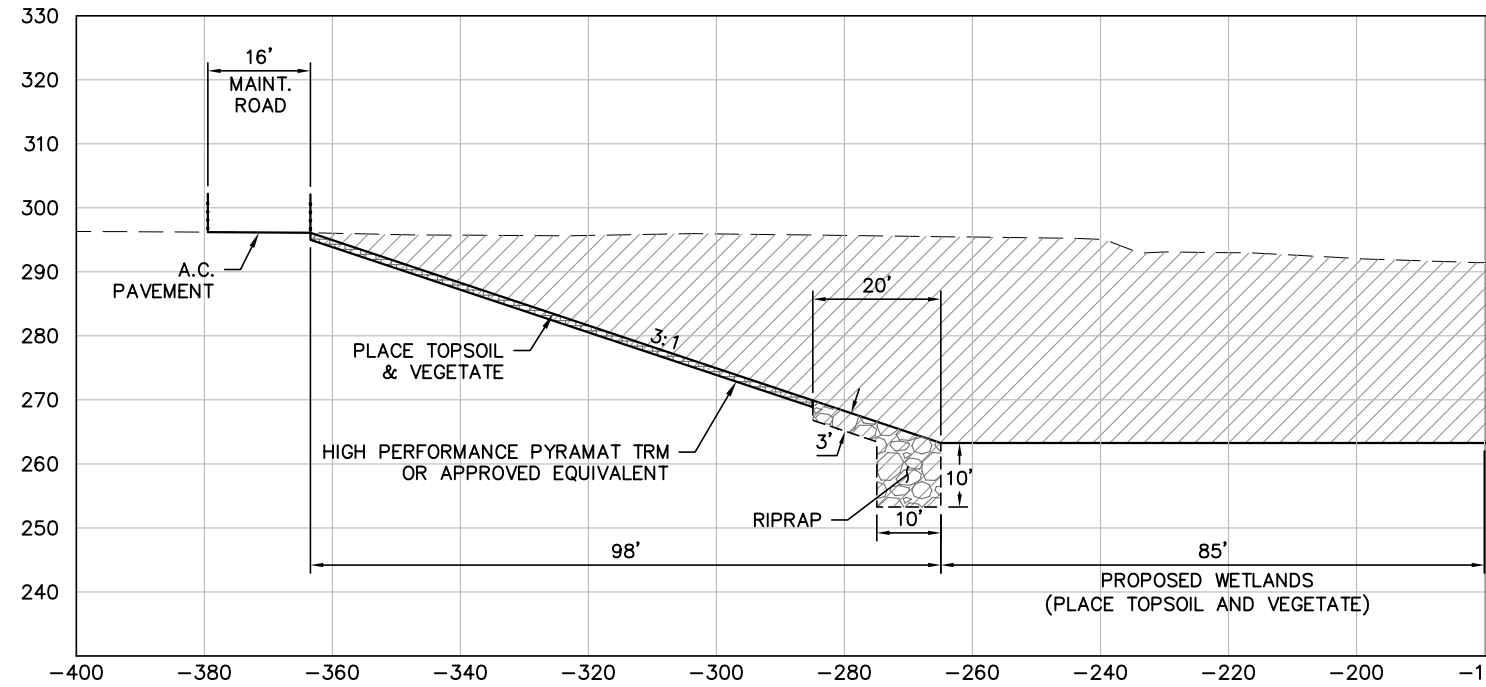

MATCHLINE STA. OFFSET -180'
SEE SECTION BELOW

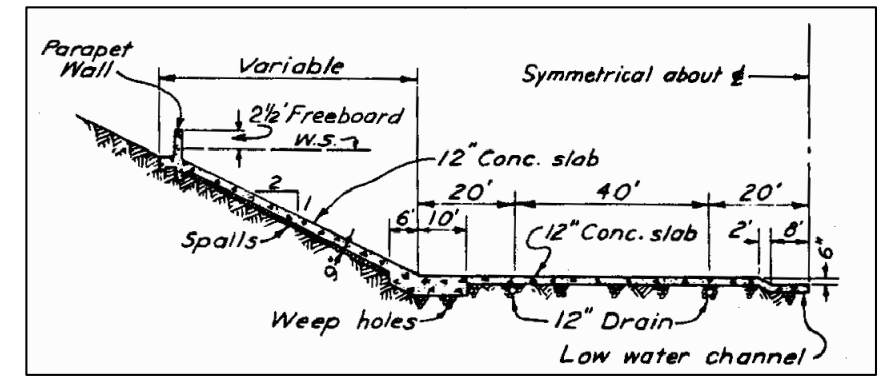

EXISTING TYPICAL SECTION
NTS

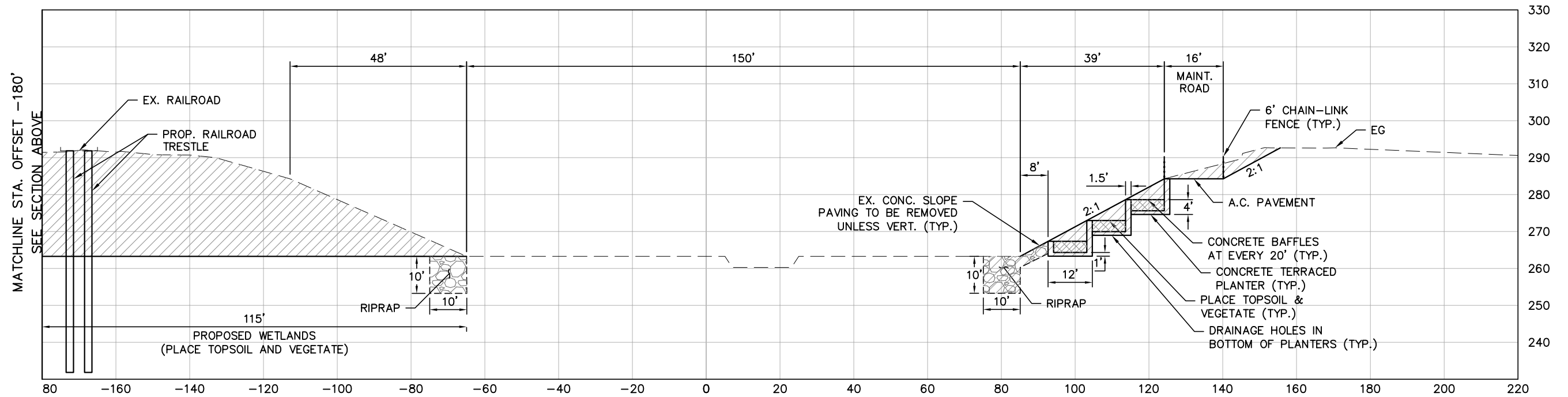

MATCHLINE STA. OFFSET -180'
SEE SECTION ABOVE

LEGEND

---	EX. GROUND		RIPRAP
—	PROPOSED CHANNEL		REINFORCED CONCRETE
	EXCAVATION		HIGH PERFORMANCE PYRAMAT TURF REINFORCEMENT MAT (TRM) OR APPROVED EQUIVALENT
	COMPACTED FILL		

NOTE: ALL DIMENSIONS SHOWN ARE APPROXIMATE AND SUBJECT TO REVISIONS DURING FINAL DESIGN.

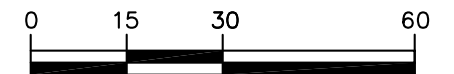

REVISIONS				LOS ANGELES RIVER FEASIBILITY STUDY PRELIMINARY DESIGN	DATE 04/16/13
MARK	DATE	DESCRIPTION	BY		
TETRA TECH, INC. 17885 Von Karman Avenue, Suite 500 Irvine, CA 92614 Phone (949) 809-5000, FAX (949) 809-5003				ALTERNATIVES 16 & 20 REACH 8 (R8A3)	
					SHT NO. 8 OF 13

This page intentionally left blank.

THIS IS A PRELIMINARY, PLANNING-LEVEL, CONCEPTUAL IMAGE USED FOR COST ESTIMATING PURPOSES ONLY.

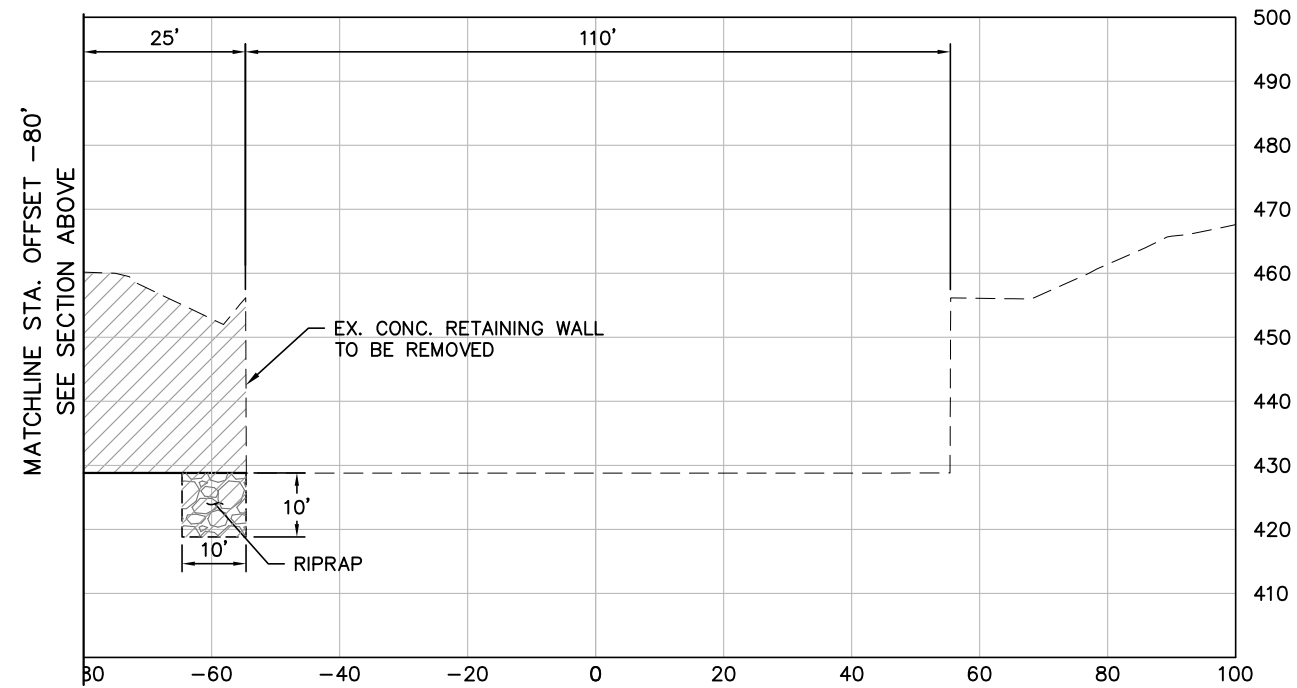
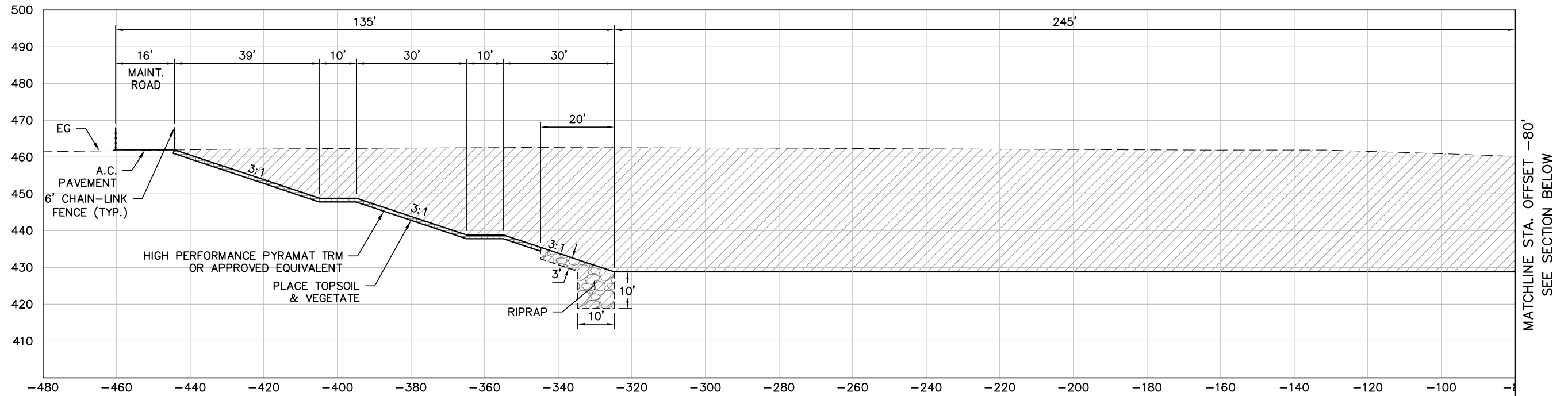

NOTE: FREEWAY PIER DEPTH/
AS-BUILT DRAWING INFORMATION BEING AQUIRED.

LEGEND

	EX. GROUND		RIPRAP
	PROPOSED CHANNEL		REINFORCED CONCRETE
	EXCAVATION		HIGH PERFORMANCE PYRAMAT TURF REINFORCEMENT MAT (TRM) OR APPROVED EQUIVALENT
	COMPACTED FILL		

NOTE: ALL DIMENSIONS SHOWN ARE APPROXIMATE AND SUBJECT TO REVISIONS DURING FINAL DESIGN

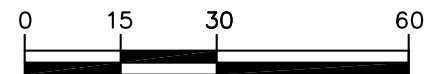

REVISIONS				LOS ANGELES RIVER FEASIBILITY STUDY PRELIMINARY DESIGN	DATE 04/16/13
MARK	DATE	DESCRIPTION	BY		
TETRA TECH, INC. 17885 Von Karman Avenue, Suite 500 Irvine, CA 92614 Phone (949) 809-5000, FAX (949) 809-5003				ALTERNATIVE 20 REACH 3 (R3A18)	SHT NO. 9 OF 13

This page intentionally left blank.

THIS IS A PRELIMINARY, PLANNING-LEVEL, CONCEPTUAL IMAGE USED FOR COST ESTIMATING PURPOSES ONLY.

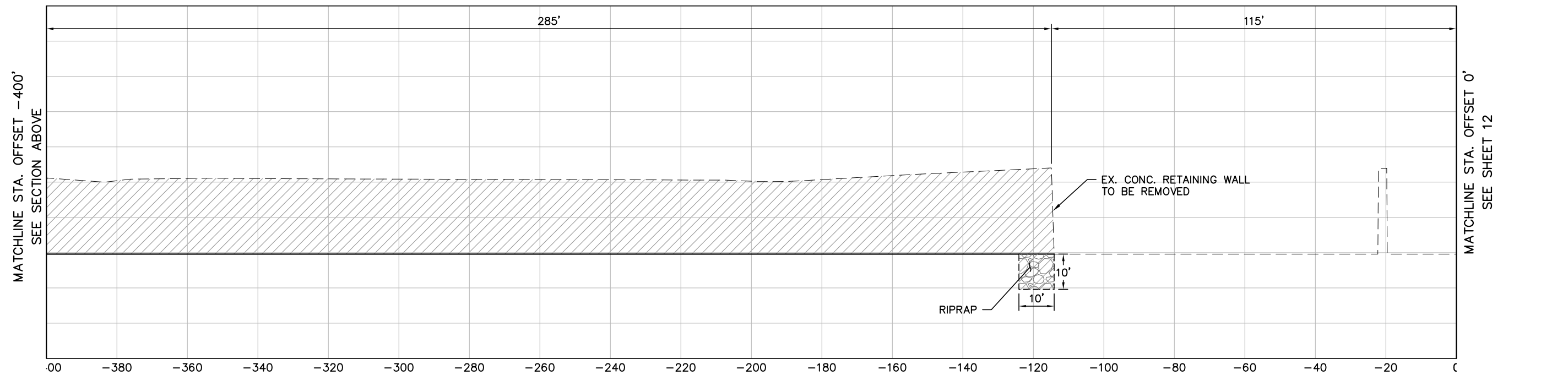
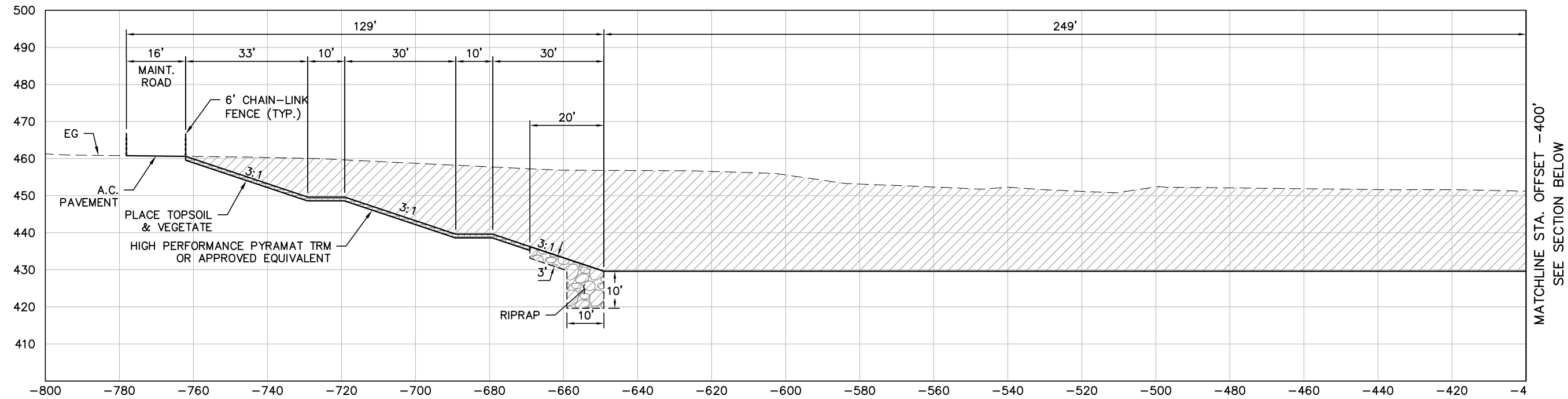

LEGEND

	EX. GROUND		RIPRAP
	PROPOSED CHANNEL		REINFORCED CONCRETE
	EXCAVATION		HIGH PERFORMANCE PYRAMAT TURF REINFORCEMENT MAT (TRM) OR APPROVED EQUIVALENT
	COMPACTED FILL		

NOTE: ALL DIMENSIONS SHOWN ARE APPROXIMATE AND SUBJECT TO REVISIONS DURING FINAL DESIGN

REVISIONS				LOS ANGELES RIVER FEASIBILITY STUDY PRELIMINARY DESIGN	DATE 04/16/13
MARK	DATE	DESCRIPTION	BY		
TETRA TECH, INC. 17885 Von Karman Avenue, Suite 500 Irvine, CA 92614 Phone (949) 809-5000, FAX (949) 809-5003				ALTERNATIVE 20 REACH 3 (R3A18)	SHT NO. 10 OF 13

This page intentionally left blank.

THIS IS A PRELIMINARY, PLANNING-LEVEL, CONCEPTUAL IMAGE USED FOR COST ESTIMATING PURPOSES ONLY.

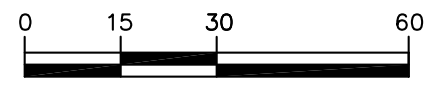
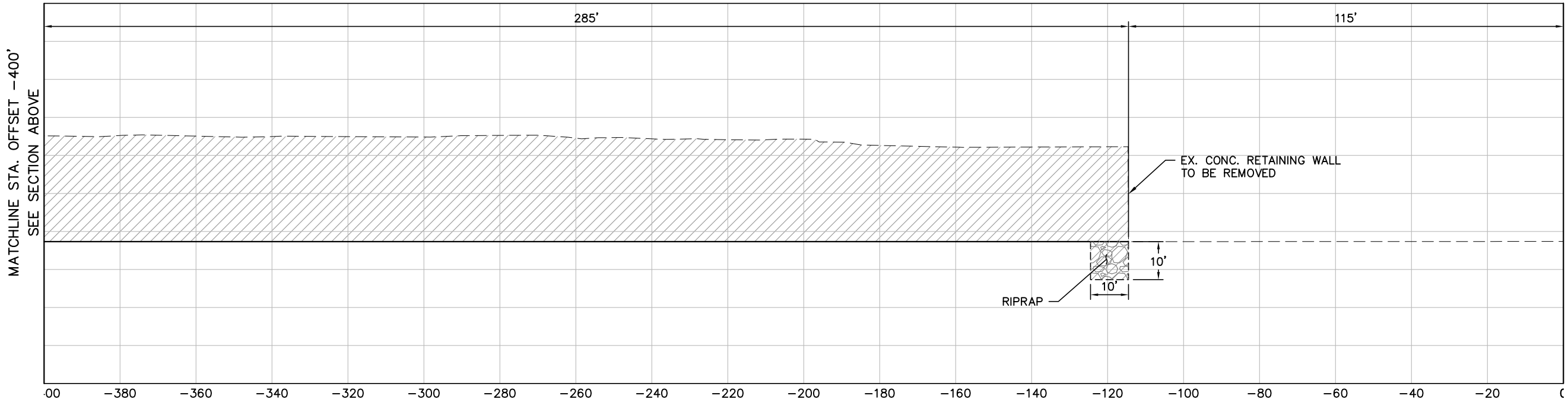
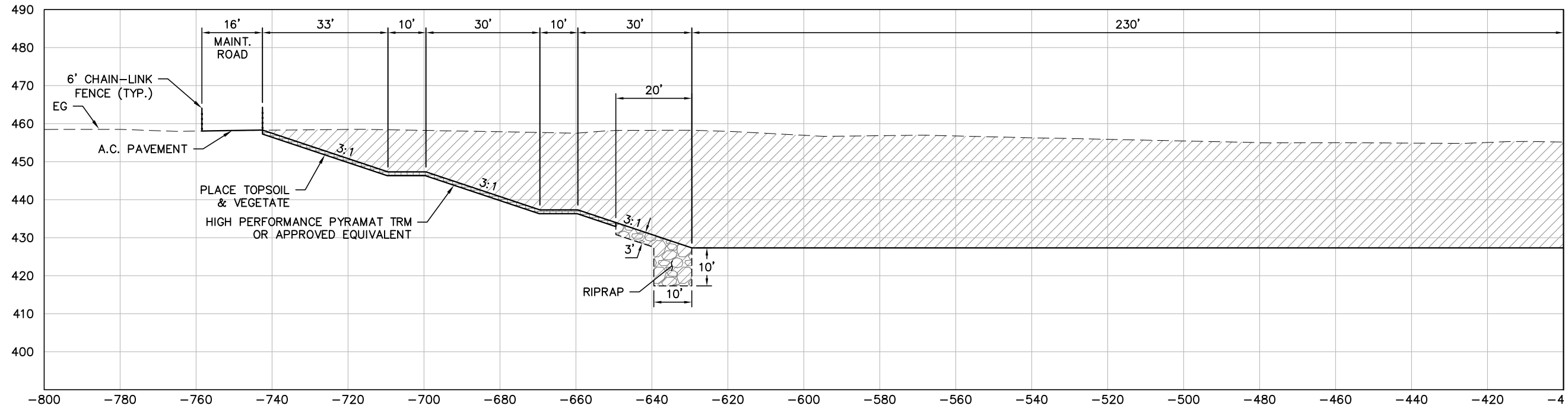

LEGEND

	EX. GROUND		RIPRAP
	PROPOSED CHANNEL		REINFORCED CONCRETE
	EXCAVATION		HIGH PERFORMANCE PYRAMAT TURF REINFORCEMENT MAT (TRM) OR APPROVED EQUIVALENT
	COMPACTED FILL		

NOTE: ALL DIMENSIONS SHOWN ARE APPROXIMATE AND SUBJECT TO REVISIONS DURING FINAL DESIGN

REVISIONS			
MARK	DATE	DESCRIPTION	BY

TETRA TECH, INC.
17885 Von Karman Avenue, Suite 500
Irvine, CA 92614
Phone (949) 809-5000, FAX (949) 809-5003



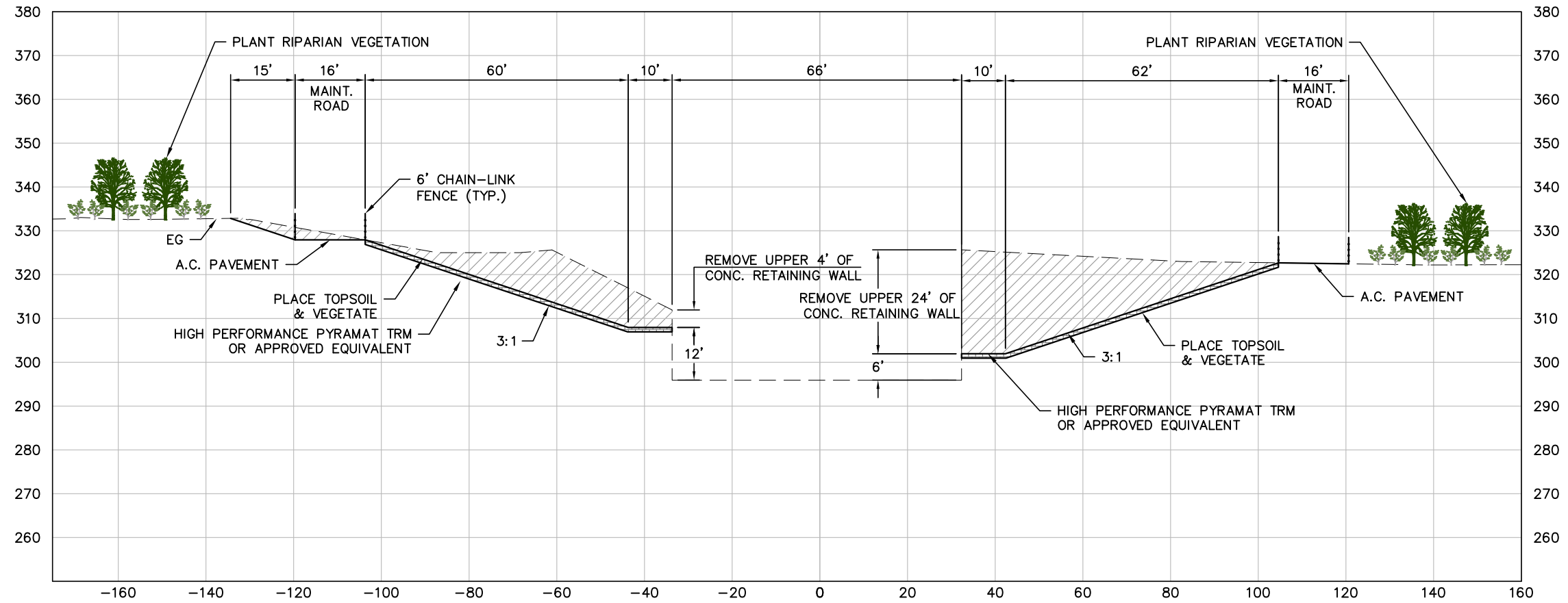

LOS ANGELES RIVER FEASIBILITY STUDY PRELIMINARY DESIGN		DATE 04/16/13
ALTERNATIVE 20 REACH 3 (R3A18)		SHT NO. 11 OF 13

This page intentionally left blank.

THIS IS A PRELIMINARY, PLANNING-LEVEL, CONCEPTUAL IMAGE USED FOR COST ESTIMATING PURPOSES ONLY.

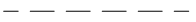

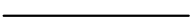
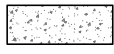
LEGEND

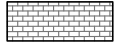
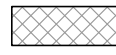
	EX. GROUND		RIPRAP
	PROPOSED CHANNEL		REINFORCED CONCRETE
	EXCAVATION		HIGH PERFORMANCE PYRAMAT TURF REINFORCEMENT MAT (TRM) OR APPROVED EQUIVALENT
	COMPACTED FILL		NOTE: ALL DIMENSIONS SHOWN ARE APPROXIMATE AND SUBJECT TO REVISIONS DURING FINAL DESIGN

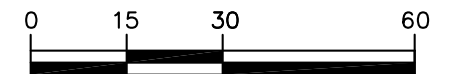

REVISIONS				LOS ANGELES RIVER FEASIBILITY STUDY PRELIMINARY DESIGN	DATE 04/16/13
MARK	DATE	DESCRIPTION	BY		
 TETRA TECH, INC. 17885 Von Karman Avenue, Suite 500 Irvine, CA 92614 Phone (949) 809-5000, FAX (949) 809-5003				ALTERNATIVES 13, 16, & 20 REACH 7 (R7A12 & R7A16)	
				SHT NO. 12 OF 13	

This page intentionally left blank.

THIS IS A PRELIMINARY, PLANNING-LEVEL, CONCEPTUAL IMAGE USED FOR COST ESTIMATING PURPOSES ONLY.

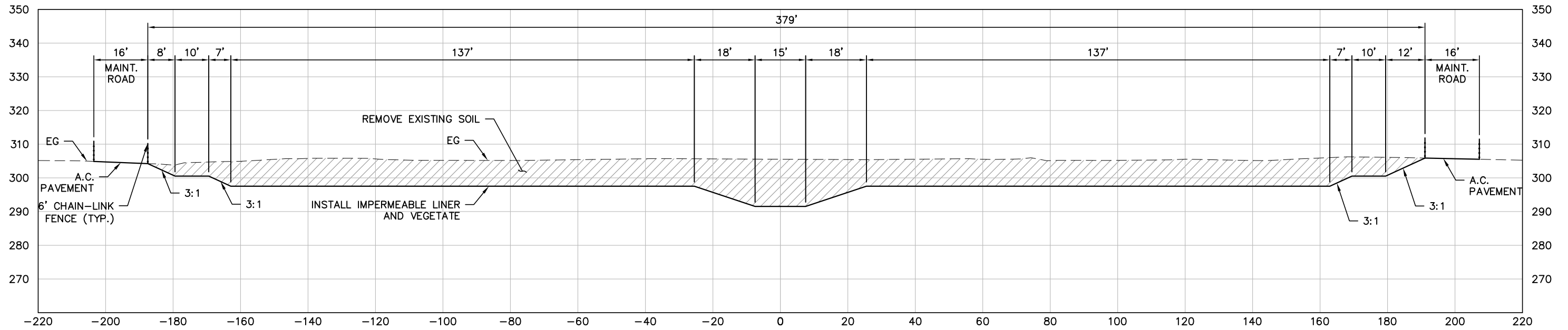

LEGEND

	EX. GROUND		RIPRAP
	PROPOSED CHANNEL		REINFORCED CONCRETE
	EXCAVATION		HIGH PERFORMANCE PYRAMAT TURF REINFORCEMENT MAT (TRM) OR APPROVED EQUIVALENT
	COMPACTED FILL		

NOTE: ALL DIMENSIONS SHOWN ARE APPROXIMATE AND SUBJECT TO REVISIONS DURING FINAL DESIGN

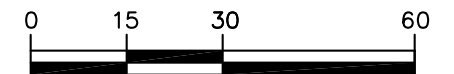

REVISIONS				LOS ANGELES RIVER FEASIBILITY STUDY PRELIMINARY DESIGN	DATE 04/16/13
MARK	DATE	DESCRIPTION	BY		
TETRA TECH, INC. 17885 Von Karman Avenue, Suite 500 Irvine, CA 92614 Phone (949) 809-5000, FAX (949) 809-5003				ALTERNATIVE 20 REACH 7 (R7A16)	SHT NO. 13 OF 13

This page intentionally left blank.